

# DAIKIN

## altherma

TM

All-in-one, all year round heating,  
cooling and domestic hot water  
supply solution



HEAT PUMP  
INVERTER  
R-410A



DAIKIN AC<sup>®</sup>  
absolute comfort

# HEAT PUMP SOLUTION TO FIT BOTH NEW BUILD HOMES AND THE HARDER TO HEAT OLDER PROPERTIES

## High Quality, Innovative Products

Innovation and quality are constantly at the forefront of Daikin's philosophy. Daikin's systems provide highly efficient solutions, which minimize the impact on the environment and running costs.

### Daikin Altherma™ Advantages over Traditional Boiler Systems

- ✓ 30 – 50% reduction in CO2 emissions
- ✓ Low running and maintenance costs
- ✓ Low noise – unobtrusive and quiet
- ✓ Easy to install, no groundwork i.e. trenches or boreholes
- ✓ Ideal for off gas grid properties
- ✓ Single phase power supply with low starting current
- ✓ Flexible, can be connected to underfloor heating, low temperature radiators or fan coils
- ✓ Advanced Energy Saving Features
  - Outdoor reset built in as standard
  - Inverter Technology
- ✓ Excellent option for net zero home- with thermal solar domestic hot water production and inverter driven compressor compatibility with photovoltaic solar.



### DID YOU KNOW...

Renewable heating and hot water solutions help save money and also help the environment



COOLING

HEATING

## 3 IN 1 SYSTEM

## FOR NEW CONSTRUCTION

## & RENOVATION

- MORE COMFORT
- LOW ENERGY CONSUMPTION
- FEWER CO<sub>2</sub> EMISSIONS



DOMESTIC HOT WATER PRODUCTION

1. **DAIKIN altherma™** Page 4  
THE 3 IN 1 GUARANTEE  
FOR ABSOLUTE COMFORT
2. **DAIKIN altherma™** Page 6  
THE BASICS
3. **DAIKIN altherma™** Page 10  
TECHNICALLY
4. **DAIKIN altherma™** Page 18  
ECONOMICALLY
5. **DAIKIN altherma™** Page 19  
APPLICATIONS
6. **DAIKIN altherma™** Page 24  
TECHNICAL SPECIFICATIONS
7. **DAIKIN altherma™** Page 30  
THE SOFTWARE

# 1. THE 3 IN 1 GUARANTEE FOR ABSOLUTE COMFORT

Daikin Altherma™ is an innovative system that **heats**, produces **domestic hot water** and can even **cool** spaces. Daikin Altherma™ offers your customer maximum comfort the whole year through.

These heat pumps are also an interesting alternative for classic gas or fuel oil heating as they offer your customers unique benefits:

- They use renewable energy sources (such as outside air)
- They deliver considerable savings in energy
- They deliver a significant contribution in the fight against CO<sub>2</sub> emissions
- They can provide heating, cooling and domestic hot water

## ENERGY EFFICIENT OPERATION

The air-to-water heat pump from Daikin uses a sustainable energy source. In fact, it extracts heat from the outside air. The system consists of a closed circuit containing R-410A refrigerant. A thermodynamic cycle is created through evaporation, condensation, compression and expansion. A heat pump “pumps” heat from a low to a high temperature level. The heat raised is transferred to the water distribution system (under floor heating, low temperature radiators and/or fan coil units) in the home via a heat exchanger.

Depending on the model and the conditions, a Daikin Altherma™ air-to-water heat pump delivers between 3 and 5 kWh of usable heat for every 1 kWh of electricity it uses. That’s a great ratio from 3:1 - 5:1!

Renovating your heating system and wanting to reduce your energy costs? Interested in a heating solution with lower energy costs? The heat pump is currently the most efficient indoor comfort system on the market: a cutting-edge technology with clear benefits for you and the environment.

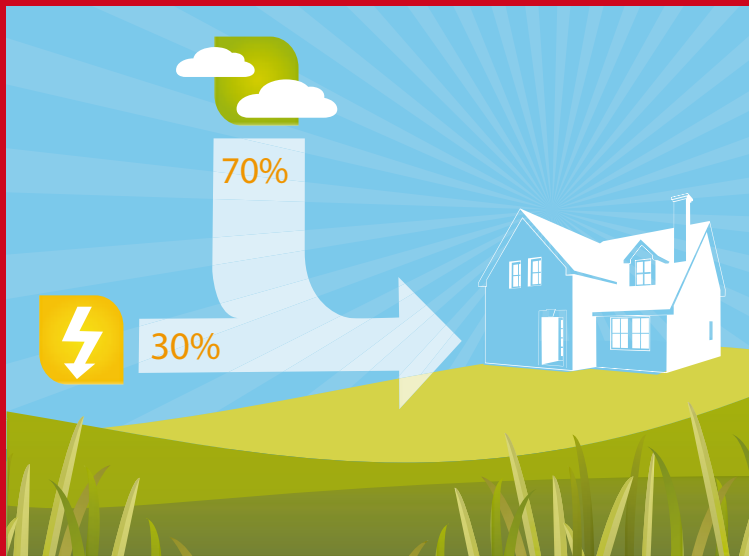

## DAIKIN HEAT PUMP EXPERIENCE

Daikin has more than 50 years of experience with heat pumps, and supplies more than one million of them to homes, shops and offices each year. This success is not just a quirk of fate: Daikin has always been at the cutting edge of technology and its goal is to provide you with turn-key comfort. Only a market leader can guarantee you this level of service and quality control!

## HIGH EFFICIENCY MEANS LOW ENERGY COSTS

Heating system efficiency is measured using the Coefficient of Performance (COP), which is the ratio of heat produced to energy consumed.

# DAIKIN OFFERS THE COMPLETE RENEWABLE SOLUTION FOR HOME HEATING AND HOT WATER

## Daikin Altherma™ Benefits for New Construction and Retrofit Installations

- ✓ Cost effective installations
- ✓ Inverter technology and weather compensation as standard
- ✓ Low energy consumption
- ✓ Reduced CO2 emissions
- ✓ Safe, easy to maintain and comfortable all year round
- ✓ No extensive ground works
- ✓ No Flues, fuel lines or fuel tanks
- ✓ Providing all your heating and hot water needs throughout the year
- ✓ A fully packaged heat pump system – no hidden 'extras'
- ✓ Superior technology ensuring performance is unaffected in a cool climate, in fact even as low as -4°F (-20°C)

### How Heat Pumps Work

A "Heat Pump" is a mover of heat, utilizing the available renewable heat from the outside air. It works on the same principle as a refrigerator, but in reverse!

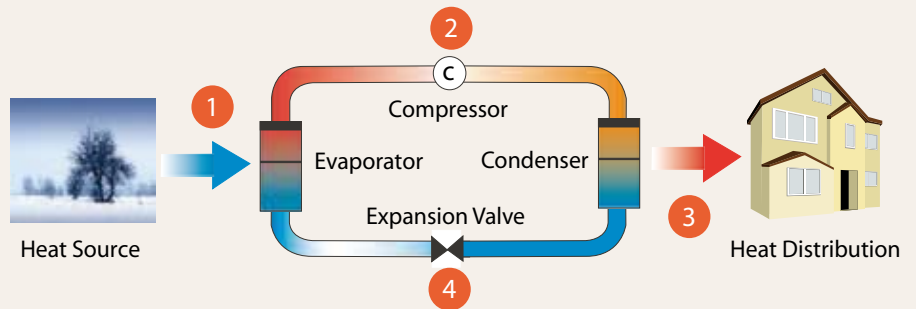

#### 1 STAGE ONE

The heat transfer medium (the refrigerant) is colder than the heat source (the outside air). As the outside air passes across the first heat exchanger (the evaporator) the liquid refrigerant absorbs the heat and evaporates.

#### 2 STAGE TWO

The vapor then passes to the compressor and is compressed. When compressed the pressure is increased and the temperature of the vapour rises, effectively concentrating the heat.

#### 3 STAGE THREE

The hot vapor passes to the second heat exchanger (the condenser) where the heat is rejected and the vapor condenses back into a liquid. In the case of Altherma the rejected heat is passed into the water of the central heating and hot water system ready for use in the home.

#### 4 STAGE FOUR

The liquid refrigerant then passes through an expansion valve, reducing its pressure and temperature, ready to start the whole cycle once again.

## ↗ DID YOU KNOW THAT...

Air source heat pumps provide 3-5kW of energy for every 1kW of electricity used

Daikin offers you the choice between a Daikin Altherma™ system with an outdoor unit and indoor unit, or a Daikin Altherma™ Monobloc System, in which the hydrobox components are located within the outdoor unit. The Daikin Altherma™ is a low temperature heating system optimized to work with radiant floor heating.

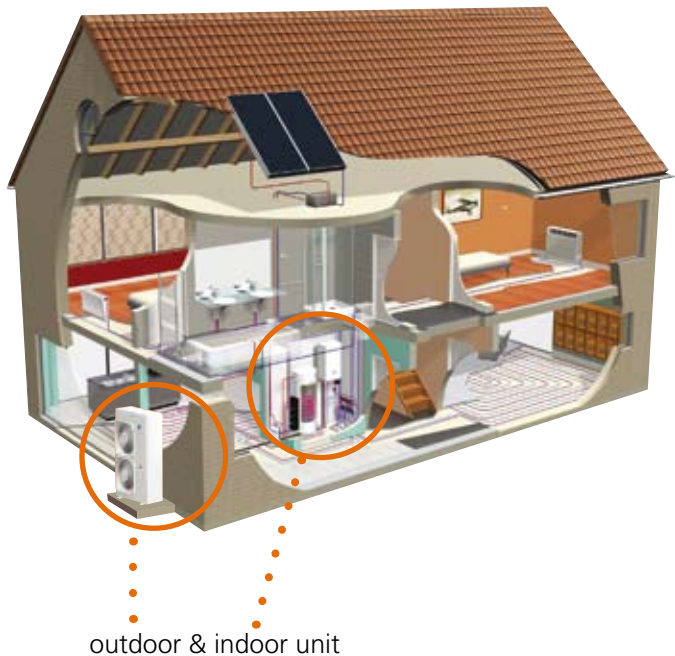
	DAIKIN ALTHERMA™ SPLIT TYPE
Application	Heating and (optional) cooling (+ domestic hot water)   <p style="text-align: center;">outdoor &amp; indoor unit</p>
Heat pump type	Outdoor (compressor) unit + Indoor (hydronic parts) unit
R-410A refrigerant piping	Between outdoor unit and indoor unit
H <sub>2</sub> O piping	Between indoor unit and indoor heating appliances
Installer's advantages	No extra insulation of H <sub>2</sub> O piping required to protect from freezing up

The Split system can be combined with:

- Under floor heating
- Fan coil units
- Low temperature radiators, to provide your customers the comfort they require.

In addition, the Split system can be connected to:

- A domestic hot water tank to supply your customer's hot water needs
- Solar collectors, with optional solar kit, to compliment the production of hot water
- A room thermostat, to regulate the ideal temperature easily, quickly and conveniently.

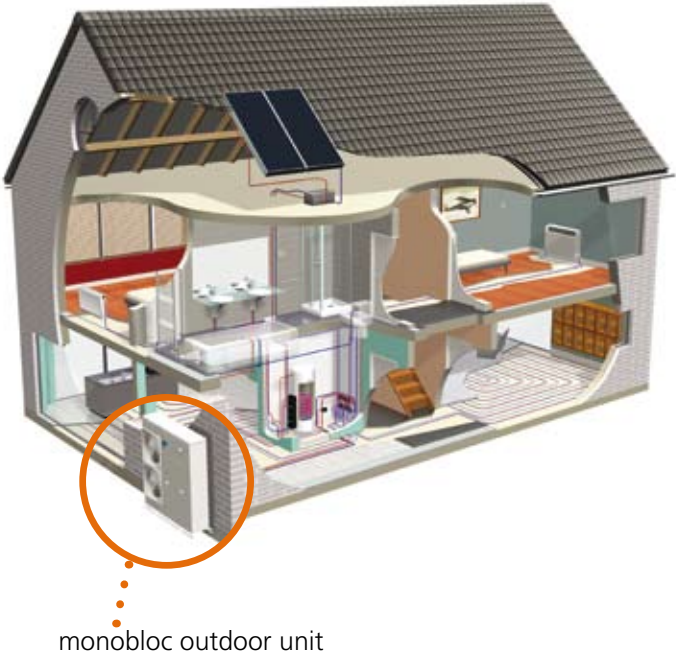
	<b>DAIKIN ALTHERMA™</b> <b>MONOBLOC</b>
Application	Heating and (optional) cooling (+ domestic hot water) 
Heat pump type	Outdoor unit only (compressor and hydronic parts combined)
R-410A refrigerant piping	Inside outdoor unit
H <sub>2</sub> O piping	Between outdoor unit and heating terminal units
Installer's advantages	Only H <sub>2</sub> O piping needed to install the system

The monobloc system can be combined with:

- Under floor heating
- Fan coil units
- Low temperature radiators, to provide your customer the comfort they require.

In addition, the monobloc system can be connected to:

- A domestic hot water tank to supply your customer's hot water needs
- Solar collectors, with optional solar kit, to compliment the production of hot water
- A room thermostat, to regulate the ideal temperature easily, quickly and conveniently.

## AIR-TO-WATER HEAT PUMP

The system consists of 5 components which together to provide the ideal comfort and water temperature.

### 1A/ OUTDOOR UNIT : AN EFFICIENT USE OF ENERGY FROM THE AIR



Daikin Altherma™ uses a natural source of energy. The outdoor unit extracts heat from the outside air and transfers it inside through refrigerant piping to supply heating. The compact outdoor unit is easily installed and, as no drilling or excavation work is required, it can also be installed in condos and apartments.

### 1B/ HYDROBOX : THE HEART OF THE DAIKIN ALTHERMA™ SYSTEM

The hydrobox heats the water that circulates through low temperature radiators, floor heating systems or fan coil units and also provides domestic hot water. If you opt for the combination of heating and cooling, then the hydrobox can also reverse the cycle to provide lower water temperatures and thus cooling to the home.

### 2/ DOMESTIC HOT WATER TANK : FOR LOW ENERGY CONSUMPTION

As for your domestic hot water, Daikin Altherma™ is just as clever. The unique lay-out and special placement of the system components maximize energy efficiency. The water inside the storage tank is primarily warmed up by thermal energy from the outside air, thanks to a heat exchanger connected to the heat pump. However, an additional electrical heating element in the domestic water tank can take care of extra heat required in the shower, tub or sink. At necessary

intervals the water is automatically heated to 158°F or more to prevent the risk of bacteria growth. With Daikin Altherma™, delightfully warm and perfectly safe water can be enjoyed at all times. Depending on the daily consumption of hot water, Daikin Altherma™ domestic hot water tanks are available in two different sizes.

- 1A/ USING HEAT PUMP TECHNOLOGY
- 2B/ WITH SOLAR KIT OPTION

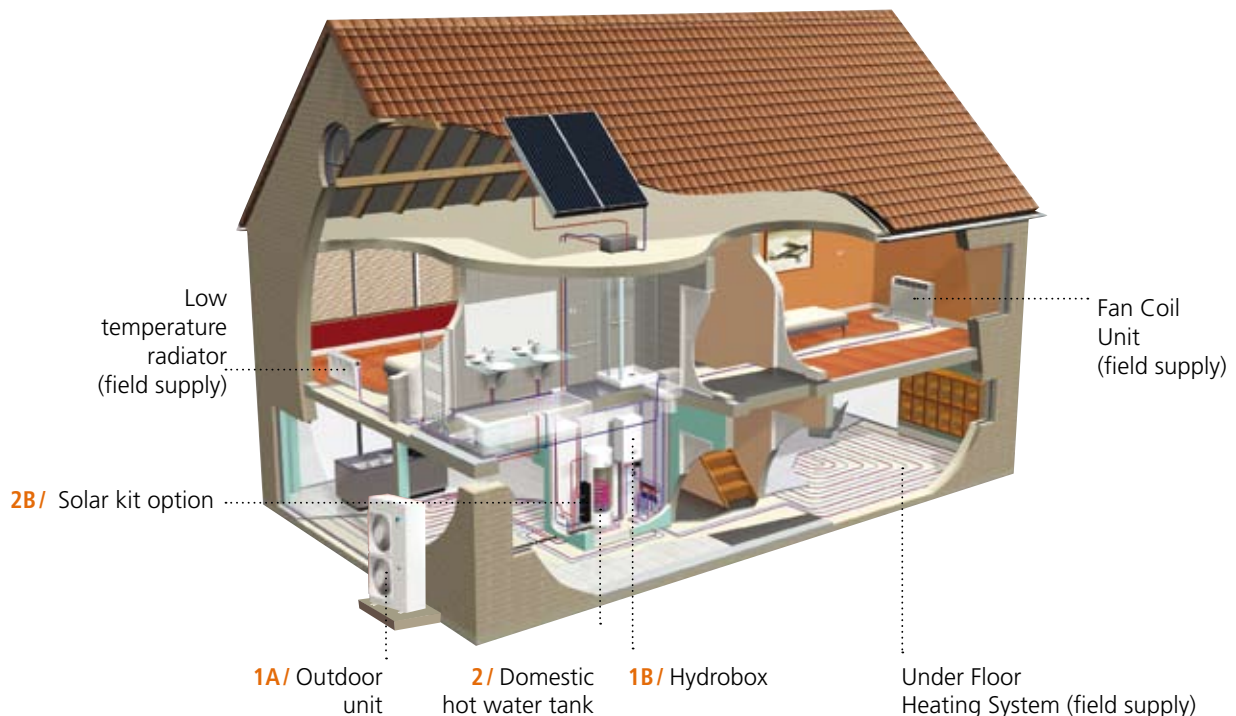

### 3/ MONOBLOC OUTDOOR UNIT: ALL IN ONE

In addition to Daikin Altherma™ Split type systems, Daikin has a monobloc version in which the hydrobox components are located within the outdoor unit. In this new system, the water pipes, rather than refrigerant

lines, run indoors from the outdoor unit, making installation much quicker and easier for the installer.

### 4/ SOLAR CONNECTION KIT

Averaged over an entire year, the sun delivers half of the energy we need to bring our domestic water up to the desired temperature for free. Your customer can use this free solar energy by connecting a solar boiler to his Daikin Altherma system. A solar boiler is a thermal solar-energy system whereby solar rays are transformed into heat. The heat is then stored in a water supply tank.

#### 4A/ SOLAR COLLECTOR PANEL (OPTION)

The high-efficiency collectors transfer all the short-wave solar radiation into heat as a result of their highly selective coating. The collectors can be mounted on the roof tiles.

#### 4B/ SOLAR PUMP STATION (OPTION)

The pump station is equipped with safety valve, pressure gauge and connection for expansion vessel, and flow and return temperature indication. A digital temperature difference controller with plain text is also included. The Solar yield (kWh) is measured by a sensor. Pump speed is controlled by the solar intensity to ensure maximum efficiency. The heat pump is disabled during solar heating as solar energy gets the first priority, which ensures system protection and maximum efficiency. The LCD controller has 7 language displays and shows fault history.

### 5/ ROOM THERMOSTAT

With the wired room thermostat, the ideal temperature can be easily, quickly and conveniently regulated.

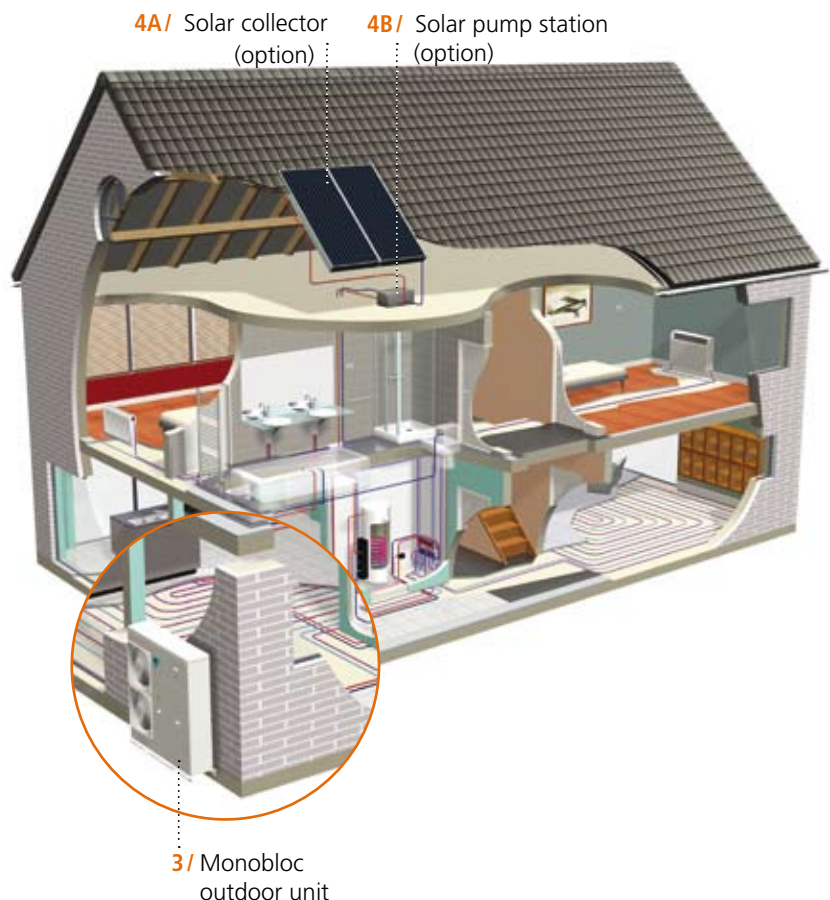

## 1 - DAIKIN ALTHERMA™ SPLIT TYPE AIR-TO-WATER HEAT PUMP

### THE OUTDOOR UNIT

- Compact, weather-resistant and easy to install
- Contains an inverter controlled compressor for energy efficiency and precise temperature regulation
- Heat pump operation range: heating and domestic hot water to -4°F (-20°C) outside temperature

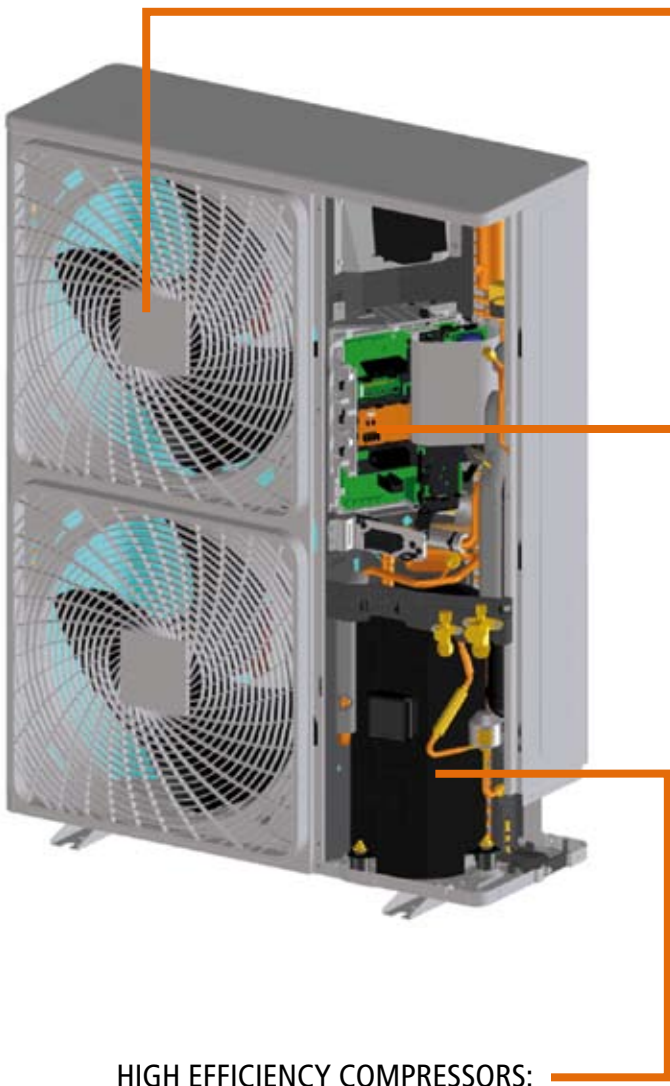

### HEAT EXCHANGER ANTI-CORROSION TREATMENT

As standard, the heat exchanger in the outdoor unit is provided with an anti-corrosion treatment. This treatment guarantees and noticeably increases the resistance against acid rain and salt corrosion.

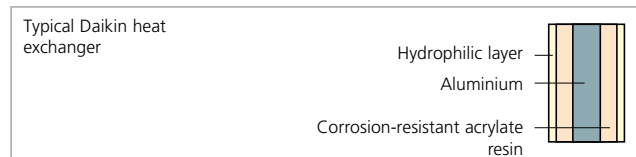

### SUPER PERFORMANCE THANKS TO THE INVERTER PRINCIPLE

The coefficient of performance (COP) of the Daikin Altherma™ heat pump is also largely attributable to the Daikin inverter principle. An integrated frequency-converter adjusts the rotational speed of the compressor to suit the heating demand. Therefore, the system seldom operates at full capacity and your customer only pays for the energy which they actually need.

#### Heating operation:

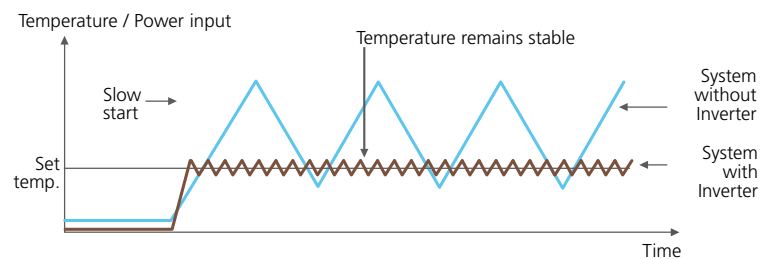

### HIGH EFFICIENCY COMPRESSORS:



The **scroll-compressors** are designed as a compact, robust, low-noise device to guarantee optimal operational reliability (no valves and built-in swing-link coupling) and efficiency (through a low initial flow and a constant compression ratio). It uses Pulse Width Modulation (PWM) Technology.



The **swing-compressors** have been setting trends in the area of energy efficient performance for the past 10 years (leaks and friction are basically non-existent). The design of the swing compressor reduces friction during operation for smoother and quieter rotation with less vibration resulting in a more durable compressor. It also minimizes the leakage of refrigerant gas during compression. The result is a system that operates quietly and efficiently. It uses Pulse Amplitude Modulation (PAM) Technology. The PAM Control reduces energy loss by controlling how often the converter switches on and off.

## HYDROBOX

- Available in two versions: EKHBH for heating only, EKHBX for heating and cooling
- Built-in electric back-up heater for additional heating during extremely cold outdoor temperatures or as back-up in case of problems with the outdoor unit
- 2 shut-off valves to assemble the water outlet and inlet
- Compact and easy to install: all components are pre-assembled, all parts are easy to reach for maintenance. Wall-mounting is comparable to a traditional gas heater.

1. Heat exchanger
2. Expansion tank (2.64 gal.)
3. Circulator
4. Tank with back-up heating
5. Air purge valve
6. Refrigerant liquid connection
7. Refrigerant gas connection
8. Water inlet connection
9. Water outlet connection
10. Pressure gauge (water circuit)
11. Water filter
12. Pressure relief valve
13. User interface
14. Switch box
15. Flow switch

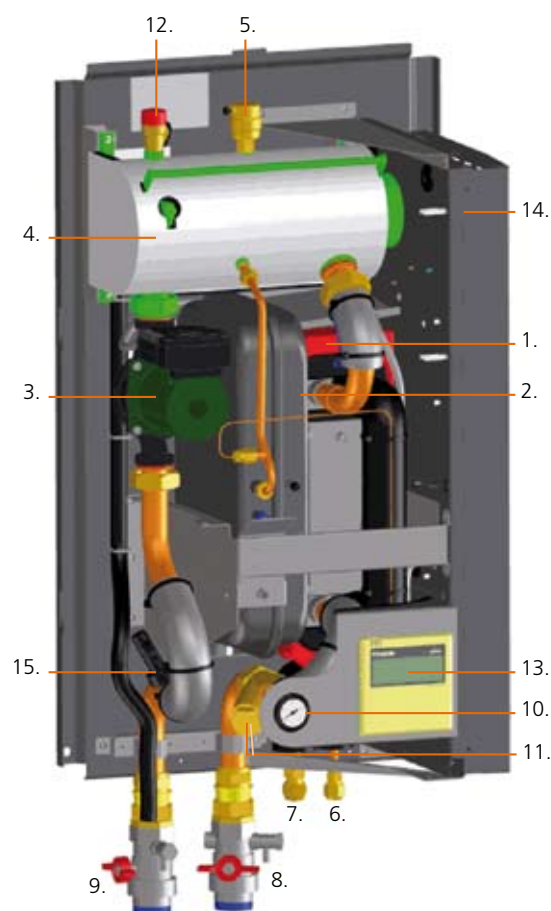

## EXTRA POSSIBILITIES THANKS TO THE INDOOR UNIT...

### Heating and Cooling

If you choose Daikin Altherma™ with an indoor unit EKHBX, it can not only heat the house, but also cool it. The heat pump is then equipped with a reversible 4-way valve, whereby the refrigeration cycle is reversed and heat is removed from the rooms. The indoor unit can cool rooms via under floor cooling or fan coil units.

### Set temperature limits

To prevent incorrect manual adjustments, temperature limits can be implemented for both cooling and heating. With under floor heating, for example, it is important that the temperature of the water is controlled to the type of floor element. To prevent condensation problems, the temperature for floor cooling can never be lower than 64.4°F (18°C). For fan coil units, the water temperature can be allowed to decrease to 41°F (5°C).

## THE USER INTERFACE

With the easy to reach digital user interface in the indoor unit, controlling the Daikin Altherma™ system is also simple for your customer. The display offers a great deal of useful information:

- Day of the week
- Time
- Operating mode  
(heating or cooling, heating domestic hot water, low-noise operating outdoor unit)
- Compressor operation
- Pump operation
- Back-up operation
- Booster heating operation  
(in the hot water tank)
- Error codes for alarm
- Temperature  
(outdoor temperature, temperature in hot water tank, leaving water temperature at indoor unit exit)



## DID YOU KNOW...

Your customer can select a maximum of five time periods each day during which the following functions will or will not be activated:

- Low-noise operation of the outdoor unit
- Electric booster heater in the hot water tank
- Heating of the domestic water
- Reduction of the water temperature

The five time periods per function are repeated daily. Your customer can still manually adjust the system when he stays home unexpectedly or stays up later. These settings are automatically switched off at the next programmed event.

## 2 - DAIKIN ALTHERMA™ MONOBLOC AIR-TO-WATER HEAT PUMP

- All hydronic parts are located within the outdoor unit
- H<sub>2</sub>O piping between outdoor unit and indoor heating apparatus

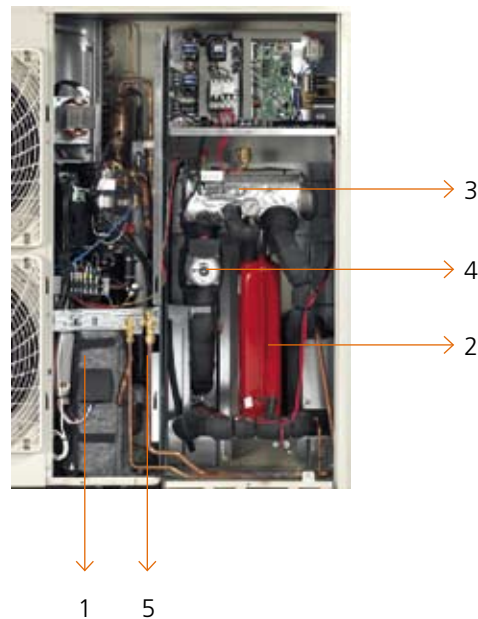

1. High efficiency compressor
2. Expansion tank
3. Tank with back up heating
4. Pressure gauge (water circuit)
5. Refrigerant connection

### ↗ DID YOU KNOW...

In order to protect the water pipes from freezing up during winter, insulation is provided for all hydronic components and special software has been applied to activate the pump and back-up heater if necessary. This prevents the water temperature from dropping below freezing point and can minimize the need for the addition of glycol to the water pipes.

- **The Daikin Altherma™ monobloc is available in different versions**

- heating only or heating and cooling
- with bottom plate heater
- single phase
- 35MBH, 48MBH, or 54MBH

- **Built-in electric back-up heater** for additional heating during extremely cold outdoor temperatures. The Daikin Altherma™ Monobloc is standard equipped with a 6 kW back-up heater, which can be adjusted to 3 kW.

If necessary, an "in line" back-up heater of 6 kW can be mounted indoors (also adjustable to 3 kW or 3.5 kW)

- The **scroll-compressors** provided are designed as a compact, robust, low-noise device to guarantee optimal operational reliability (no valves and built-in swing-link coupling) and efficiency (through a low initial flow and a constant compression ratio).



### 3 - THE DOMESTIC HOT WATER TANK

- Available in 2 capacities: 50 and 80 gallons for floor mounted installation.
- Stainless steel design.
- 1 37/64" cfc-free insulation material (polyurethane).
- Contains 2 heating elements: a heat exchanger at the bottom where the hot water from the hydrobox circulates and an extra 3 kW electric heater at the top.
- A thermistor in the hot water tank controls a 3-way valve and/or booster heater via the hydrobox.



1. Field supply
2. Hot water connection (H)
3. Pressure relief valve connection
4. Pressure relief valve (field supply)
5. Electrical box
6. Electrical box lid
7. Recirculation hole
8. Thermistor socket
9. Flow inlet connection (F) (from main unit)
10. Heat exchanger coil
11. Return outlet connection (R) (to main unit)
12. Cold water connection (C)
13. Threaded thermistor hole for use with solar kit option. (Refer to the Installation manual EKSOLHWBAVJU).
14. Temperature and pressure relief valve connection
15. Thermal protectors (Q2L, Q3L)
16. Booster heater

 Flow direction

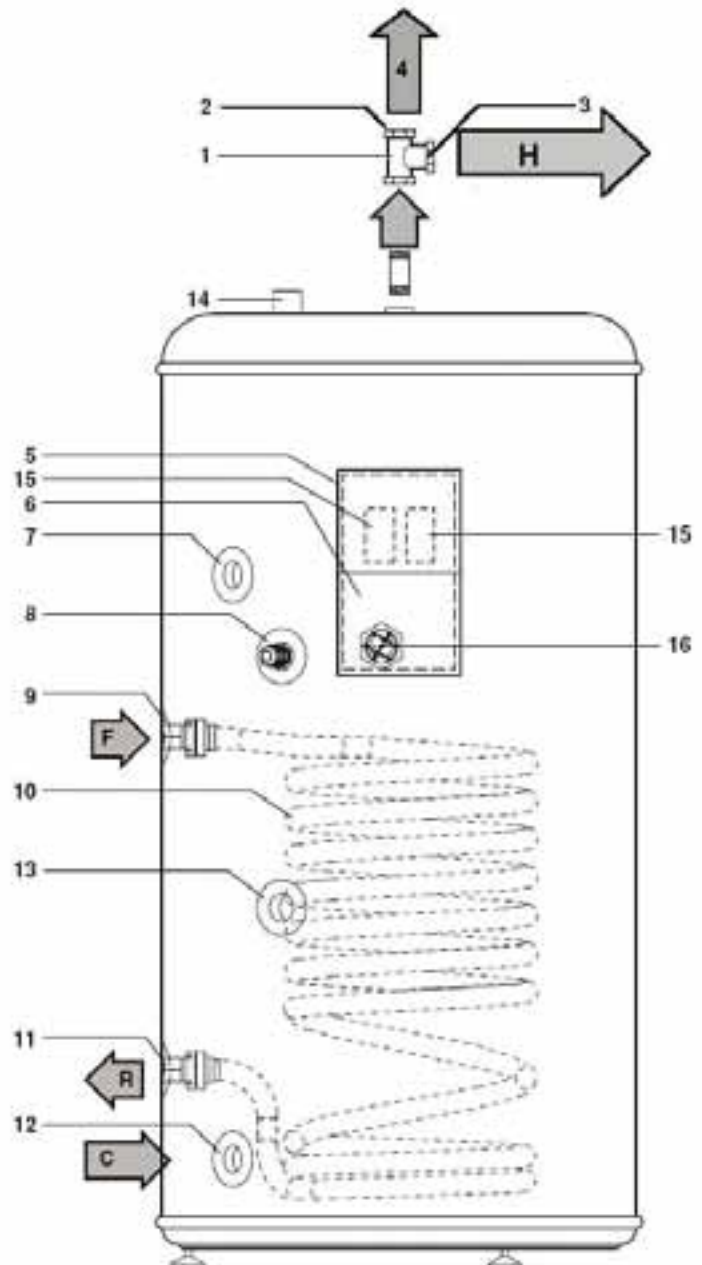

## MULTIFUNCTIONAL HOT WATER TANK ...

### ■ Stainless steel

Daikin offers a tank made of stainless steel equipped with a sacrificial rod to protect the tank against corrosion.

### ■ Anti-bacteria function

To prevent the development of bacteria, the hot water tank is equipped with an anti-bacteria function. You can set up the program so the water is heated to a specific temperature (standard setting = 158°F (70°C)) at a set time on one or more days of the week.

### ■ Flexible control

It is possible to set "priority setting" for the production of domestic hot water. In this way the customer has domestic hot water available at any time of the day.

The heating of the domestic hot water can also be set up according to the night tariff. Another opportunity for rational energy consumption.

### ■ Regulating switch-on and shut-off temperatures

You personally set the minimum and maximum temperature when the water in the tank must be heated by the heat pump for the customer.

### ■ Delaying booster heater switch-off

To prevent the booster heater from switching on and off too often, you can allow the system to switch off as soon as the temperature reaches a maximum of 39°F (22°C) higher than the set temperature.

### ■ Allowing back-up heater and booster heater to work separately

Programming the system to prevent the simultaneous operation of the back-up heater and the booster heater is also possible. An interesting possibility for homes with a limited current amp load!

### ■ No natural gas or fuel oil connection or exhaust fume channel required.

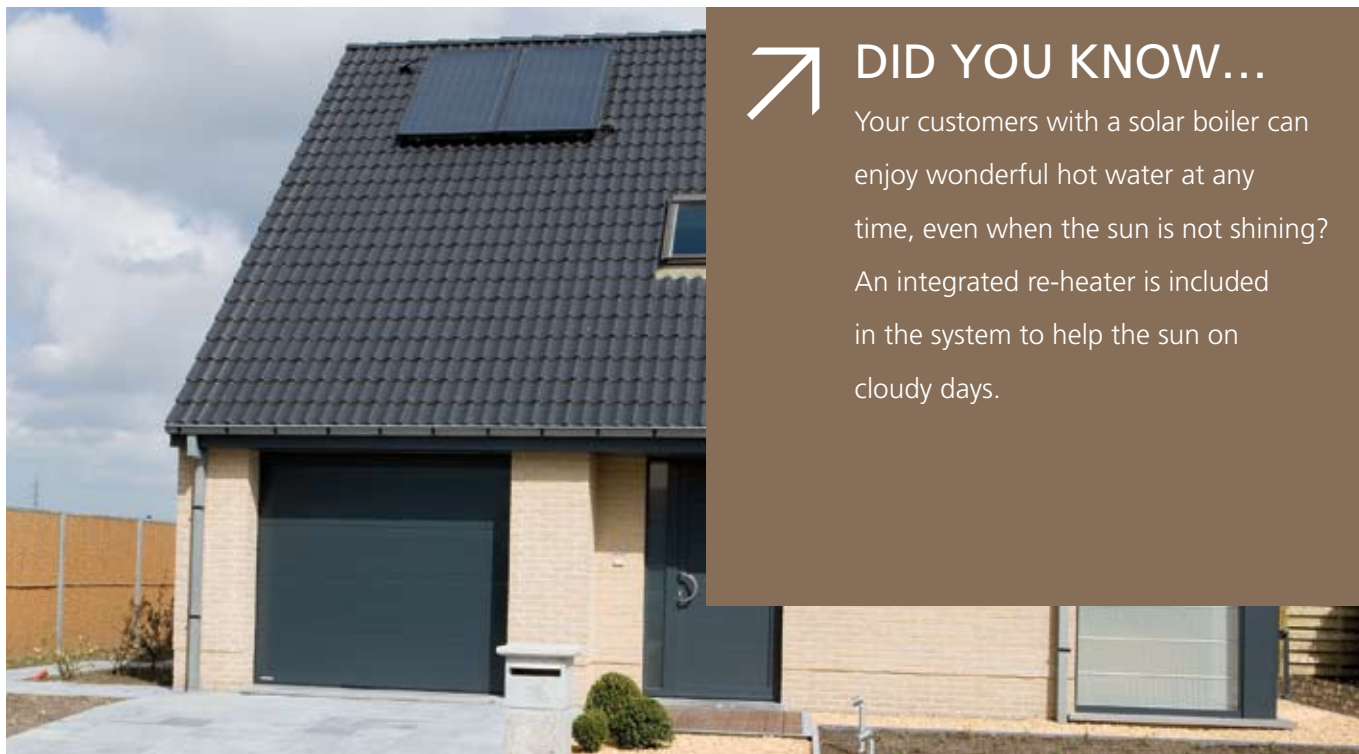

## DID YOU KNOW...

Your customers with a solar boiler can enjoy wonderful hot water at any time, even when the sun is not shining? An integrated re-heater is included in the system to help the sun on cloudy days.

## 4 - SOLAR CONNECTION

### SOLAR THERMAL BOILER

Averaged over an entire year, the sun delivers half of the energy we need to bring our domestic water up to the desired temperature for free. Your customer can use this solar energy by connecting a solar boiler to the Daikin Altherma™ system. A solar boiler is a thermal solar-energy system, whereby solar rays are transformed into heat. The heat is then stored in a water supply tank.

### SOLAR KIT

The solar kit provides the transfer of solar heat to the Daikin Altherma™ hot water tank via an external heat exchanger. In contrast to tanks with two heat exchangers, this system allows the entire content of the tank to be efficiently heated with solar heat and, if necessary, with heat pump energy.

### SOLAR SYSTEM

The high-efficiency collectors transfer all the short-wave solar radiation into heat as a result of their highly selective coating. The collectors can be mounted on the roof tiles. The solar kit controller and pump station provide the transfer of solar heat to the Daikin domestic hot water tank via an external heat exchanger. In contrast to tanks with two heat exchangers, this system allows the entire content of the tank to be efficiently heated with solar heat and, if necessary, with heat pump energy.



### Daikin Altherma™ solar boiler assembly

- Solar collector (option)
- Plumbing network and solar pump station (option)
- Supply tank: standard Daikin Altherma™ domestic hot water tank
- Solar kit
- Re-heater (Daikin Altherma™ heat pump unit, which also provides the home with heating)

Available with all models



1. Solar collector  
(Flat plate collector)  
(option)

2. Hydrobox

3. Domestic Hot Water Tank

4. Solar kit

5. Solar pump station  
(option)

## 5 - THE ROOM THERMOSTAT

The large LCD screen on the room thermostat indicates all the necessary information regarding the setting of the Daikin Altherma system in a blink of an eye. The user can also easily navigate between the different menus whose most common functions and modes include:

- Setting the temperature of the room based on measurements from the built-in sensor
- Cooling and heating mode
- Off function (with integrated frost-protection function)
- Vacation function mode
- Comfort and reduced function modes
- Time (day and month)
- Programmable weekly timer with 2 standard and 5 pre-set programs
- Keylock function
- Setting limits. The installer can change the upper and lower limits



Functions	Wired room thermostat EKRTWA
Heating only	✓
Heating and cooling	✓
Comfort function mode	✓
Reduced function mode	✓
Scheduled function mode	✓
Number of setpoint changes	12/day
Holiday function mode	✓
Off function	✓
Setpoint limitation	✓
Keylock function	✓

### ↗ DID YOU KNOW THAT...

Daikin has set up a number of monitoring sites (in Europe, Oregon, New Hampshire, Alaska, ...), where Daikin Altherma has been tested under totally different climate conditions. High satisfaction has been achieved with increased comfort, stable indoor temperature, low energy consumption and hot water always available... whatever the weather conditions at the monitoring site.



## How We Use Energy in Our Homes

Heating and cooling account for the largest portion of a typical utility bill.

Source: 2007 Buildings Energy Data Book, Table 4.2.1., 2005 energy cost data.

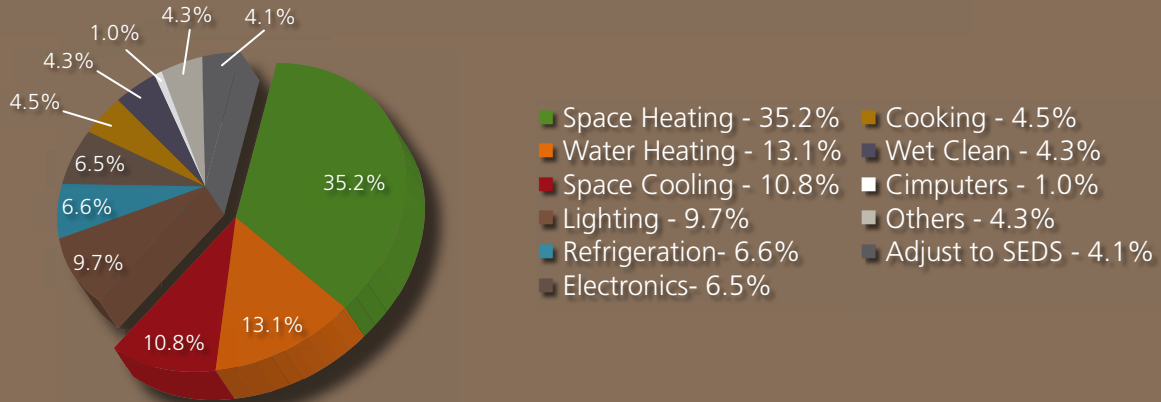

- Customers today are, more than ever, conscious of the cost of heating.
- There is not only the increasing cost of fuel oil and natural gas, but also the limited supply of fossil fuels and the problem of CO<sub>2</sub> emissions.
- Energy efficient heating solutions are gaining in popularity.
- Daikin Altherma™ debuted in Europe in 2006 and since then has demonstrated significant economical advantages over traditional systems as highlighted on the following graphics:

### 1. 66 To 80% Additional Heat

A heat pump boiler works more efficiently and saves more energy than a traditional heating system using fossil fuel. Daikin Altherma™ generates at least 3 to 5 kW of additional heat per 1kW of electricity used. Talk about a good investment.

#### OPERATING COSTS:

Conditions: Required annual heating energy: 20,000 kWh. Source: Energy prices based on EUROSTAT statistics [first semester 2007].

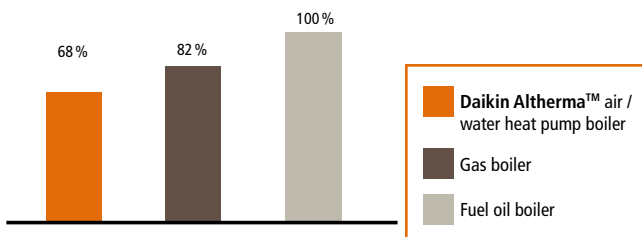

### 2. PER (primary energy ratio)

This is the relationship between the useable energy generated and the primary energy consumed, with consideration for the electricity production efficiency and the electricity distribution.

#### LOW PRIMARY ENERGY CONSUMPTION

Conditions : For combustion systems, the PER indicates the overall efficiency of the system, while for heat pumps it is equal to the seasonal performance factor multiplied by the electricity production efficiency which on average is 0.4 in the European Union.

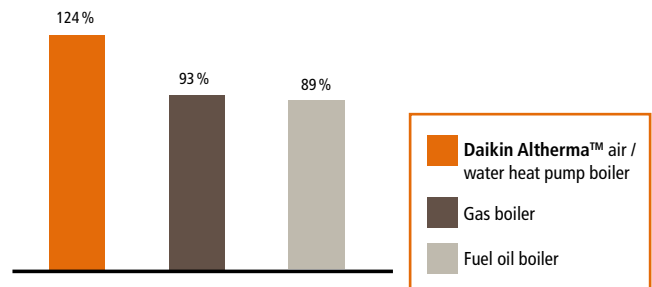

### AVERAGE ANNUAL CO<sub>2</sub> EMISSIONS

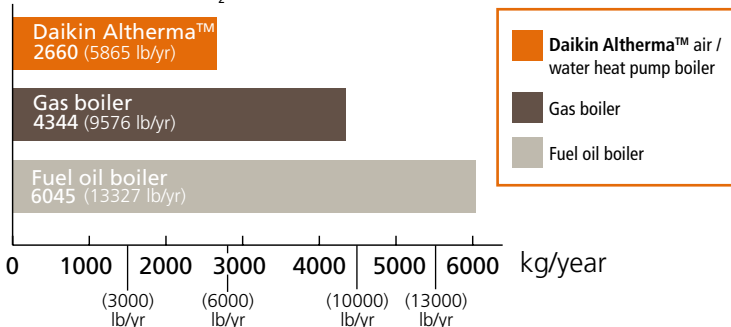

### LOWER CO<sub>2</sub> EMISSIONS

Daikin Altherma™ produces no direct CO<sub>2</sub> emissions, so you personally contribute to a better environment. The system does use electricity, but even without renewable electricity the CO<sub>2</sub> emissions are still much lower than boilers that use fossil fuels.

Calculation based on data from Eurelectric (organization of European electricity producers), "Eurelec Program - 2001" for EU27

## DESIGN STEP 1

Define the leaving water temperature range of the necessary heat emitters and the heat load.

## DESIGN STEP 2

Calculation of heat losses (Transmission and ventilation losses)

## DESIGN STEP 3

Selection of the Daikin Altherma™ system based on heat loss calculation.  
Tip: Use the available Daikin Altherma™ selection and software tools.

## DAIKIN ALTHERMA™ SYSTEM CONFIGURATIONS

### MONO-VALENT

- Uses heat pump energy only
- Ideal for new construction
- 100% heat pump coverage: selection of bigger capacity and higher investment cost heat pump

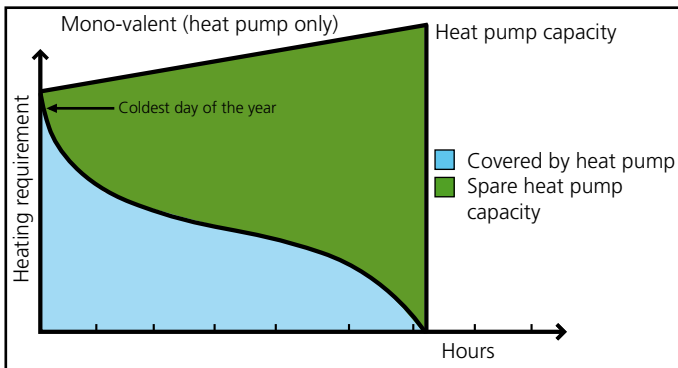
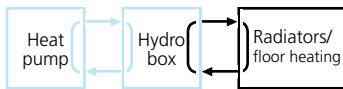

### MONO-ENERGETIC

- Uses heat pump energy with backup electric heater
- Ideal for new construction
- Best balance between investment cost and running cost, results in lowest lifecycle cost

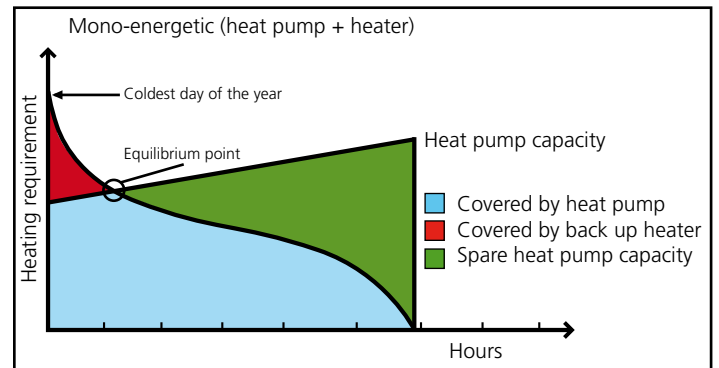
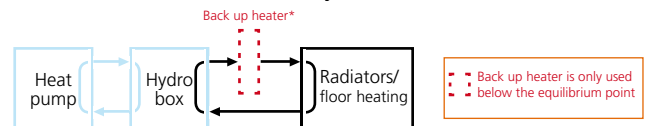

### BI-VALENT

- Uses heat pump energy with auxiliary boiler
- Ideal for refurbishment/upgrade

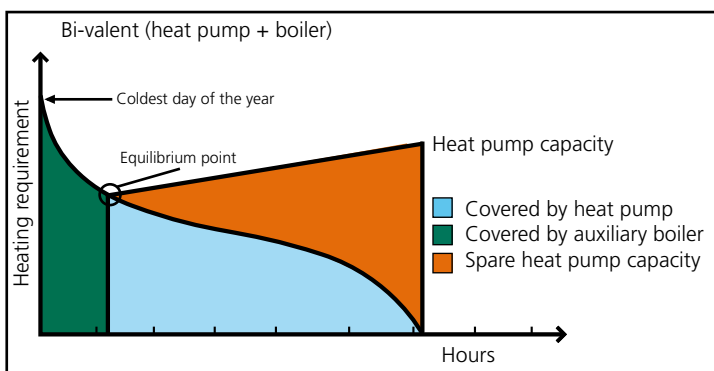
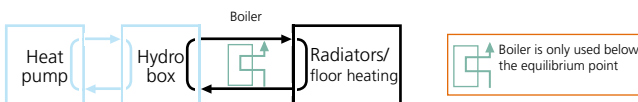

### SPACE HEATING WITH AN AUXILIARY BOILER

1. Space heating application by either the Daikin Altherma™ Hydrobox or by an auxiliary boiler connected in the system.
2. An auxiliary contact decides whether the Hydrobox or the boiler will operate.
3. The auxiliary contact can be an outdoor temperature thermostat, an electricity tariff contact, a manually operated contact, etc...
4. Domestic hot water in such an application is always produced by the system tank connected to the Hydrobox, including when the boiler is in operation for space heating.

## DAIKIN ALTHERMA™ SPLIT TYPE APPLICATIONS

### 1. Application "heating only" with a room thermostat connected to the indoor unit

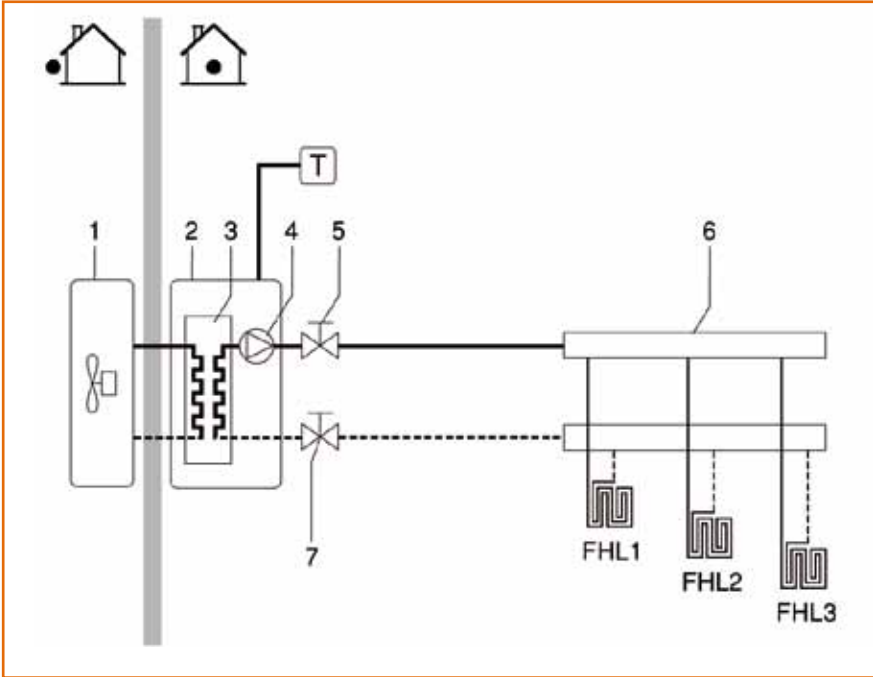

- 1. Outdoor unit
- 2. Hydrobox
- 3. Heat exchanger
- 4. Pump
- 5. Valve
- 6. Manifold (field supply)
- 7. Valve

FHL1...3 (Under) floor heating loop (field supply)  
 T Room thermostat

### 2. Application "heating" and "production of domestic hot water"

The temperature in each room is regulated by a valve on every water circuit. Hot water for domestic use is delivered by the domestic hot water tank connected to the indoor unit.

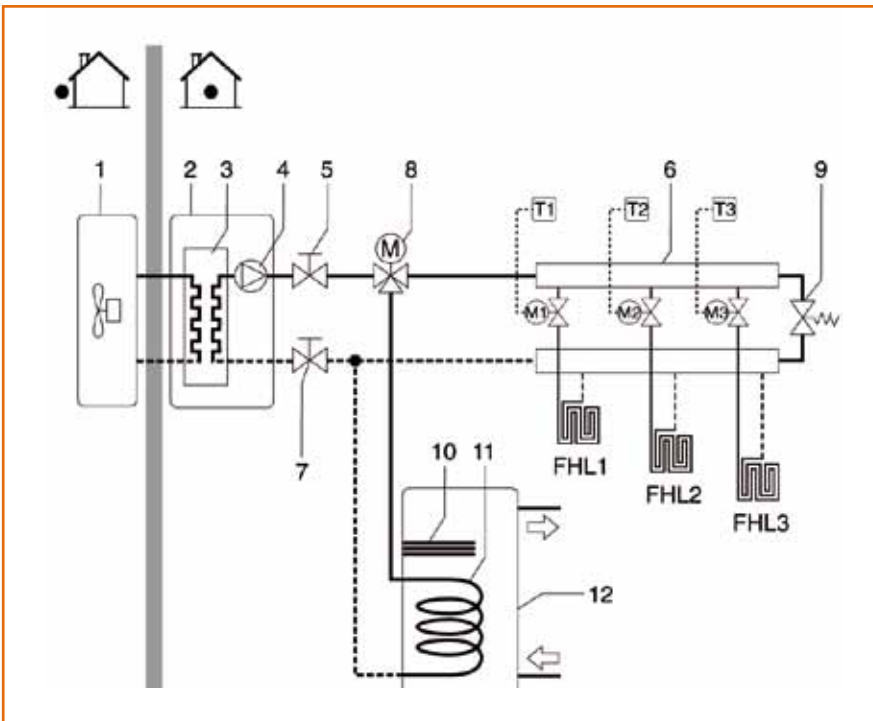

- 1. Outdoor unit
- 2. Hydrobox
- 3. Heat exchanger
- 4. Pump
- 5. Valve
- 6. Manifold (field supply)
- 7. Valve
- 8. Motorized 3-way valve
- 9. Pressure relief valve
- 10. Booster heater
- 11. Heat exchanger spiral
- 12. Tank for domestic hot water

FHL1...3 (Under) floor heating loop (field supply)  
 T 1...3 Individual room thermostat

### 3. Application “heating/cooling” via room thermostat and “production of domestic hot water”

Heating using under floor heating loops and fan coil units. Cooling using only the fan coil units.

Hot water for domestic use is delivered by the domestic hot water tank connected to the indoor unit.



1. Outdoor unit
2. Hydrobox
3. Heat exchanger
4. Pump
5. Valve
6. Manifold (field supply)
7. Valve
8. Motorized 3-way valve
10. Booster heater
11. Heat exchanger spiral
12. Tank for domestic hot water
13. Motorized 2-way valve (field supply)

FCU1...3 Fan coil unit (field supply)  
 FHL1...3 (Under) floor heating loop (field supply)

T Room thermostat with cooling / heating switch

### 4. Bi-valent application

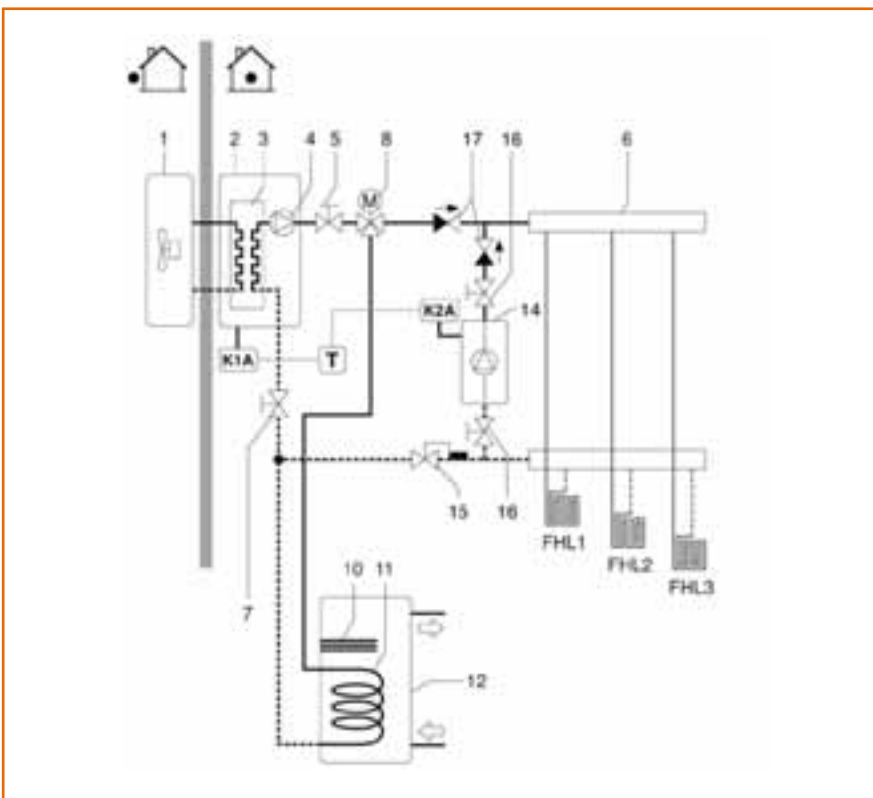

1. Outdoor unit
2. Hydrobox
3. Heat exchanger
4. Pump
5. Valve
6. Manifold (field supply)
7. Valve
8. Motorized 3-way valve
10. Booster heater
11. Heat exchanger spiral
12. Tank for domestic hot water
14. Alternate heating device (field supply)
15. Aquastat (field supply)
16. Valve (field supply)
17. One-way valve (field supply)

FHL1...3 (Under) floor heating loop (field supply)

K1A Relay for activating EKHB\* unit (field supply)

K2A Relay for activating hot water tank (field supply)

T Room thermostat

## DAIKIN ALTHERMA™ MONOBLOC APPLICATIONS

### 1. Application "heating only" with a room thermostat connected to the indoor unit

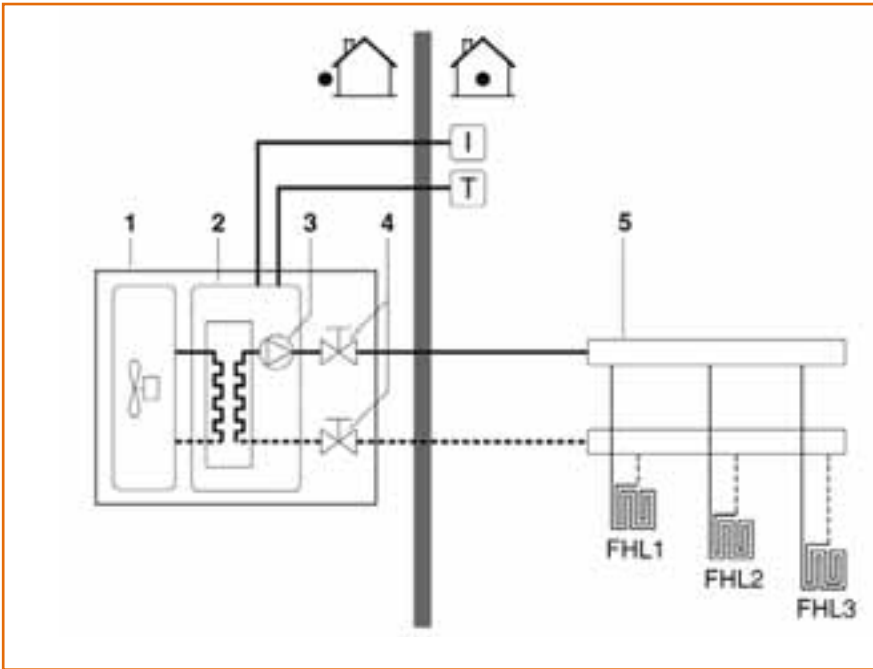

1. Unit
2. Heat exchanger
3. Pump
4. Shut-off valve
5. Collector (field supply)

FHL1...3 Floor heating loop (field supply)

T Room thermostat (field supply)

I User interface

### 2. Application "heating" and "production of domestic hot water"

The temperature in each room is regulated by a valve on every water circuit. Hot water for domestic use is delivered by the domestic hot water tank connected to the unit.

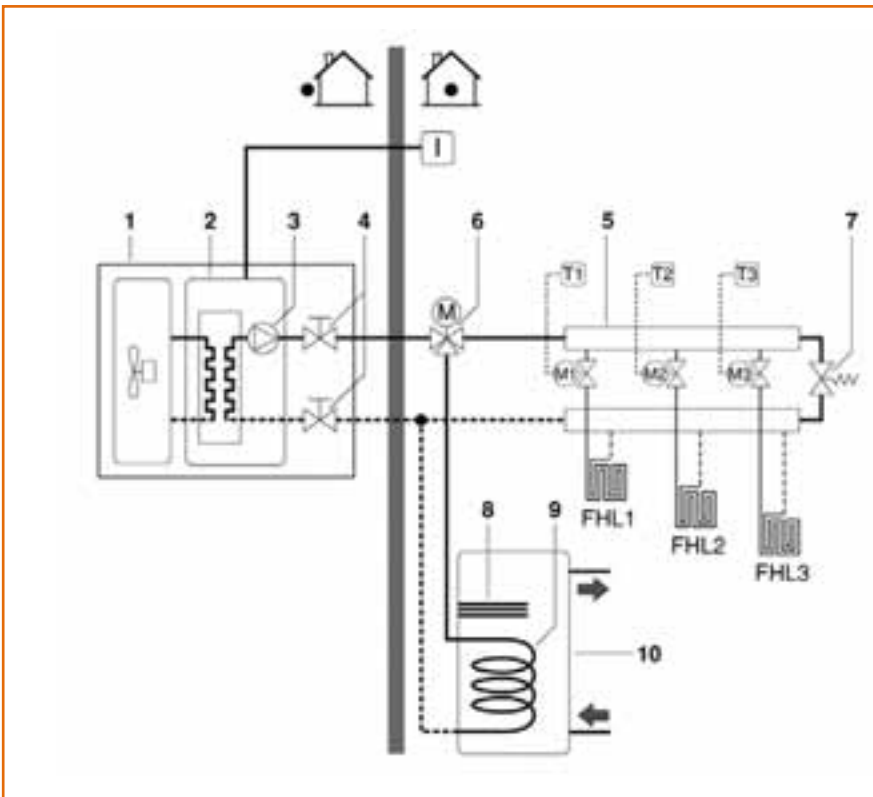

1. Unit
2. Heat exchanger
3. Pump
4. Shut-off valve
5. Collector (field supply)
6. Motorized 3-way valve
7. By-pass valve (field supply)
8. Booster heater
9. Heat exchanger coil
10. Domestic hot water tank

FHL1...3 Floor heating loop (field supply)

T 1...3 Individual room thermostat (field supply)

M 1...3 Individual motorized valve to control loop FHL1 (field supply)

I User interface

### 3. Application "heating/cooling" via room thermostat and "production of domestic hot water"

Heating using under floor heating loops and fan coil units. Cooling using only the fan coil units.

Hot water for domestic use is delivered by the domestic hot water tank connected to the unit.

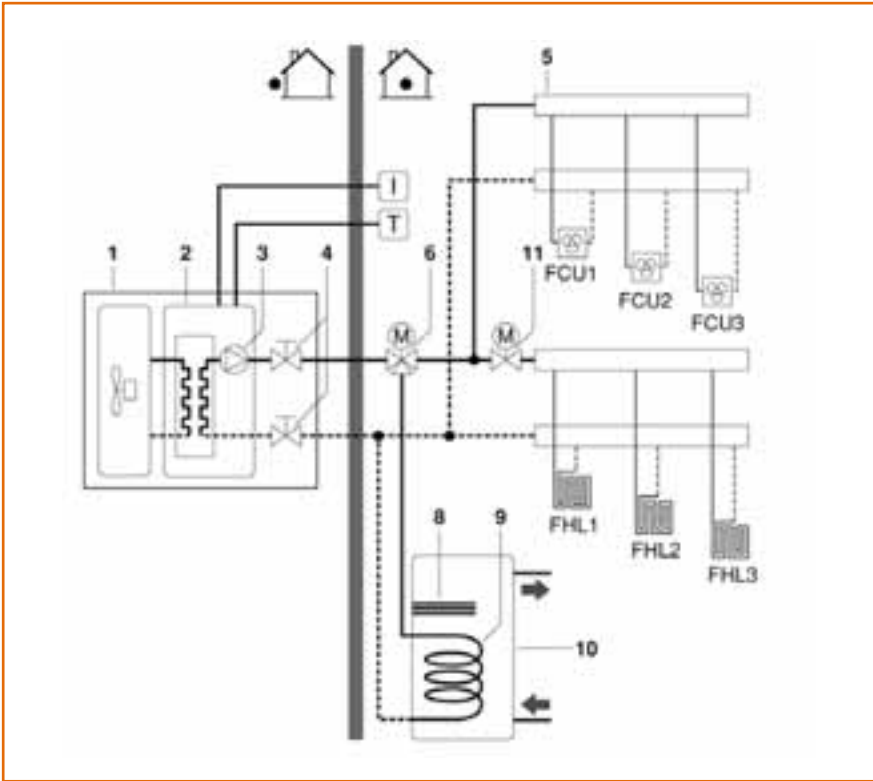

1. Unit
2. Heat exchanger
3. Pump
4. Shut-off valve
5. Collector (field supply)
6. Motorized 3-way valve
8. Booster heater
9. Heat exchanger coil
10. Domestic hot water tank
11. Motorized 2-way valve (field supply)

- FCU1...3 Fan coil unit (field supply)  
 FHL1...3 Floor heating loop (field supply)  
 T Room thermostat with cooling/heating switch (field supply)  
 I User interface

### 4. Application "heating/cooling" without a room thermostat

but with a heating only room thermostat controlling the underfloor heating and a cooling/heating thermostat controlling the fan coil units.

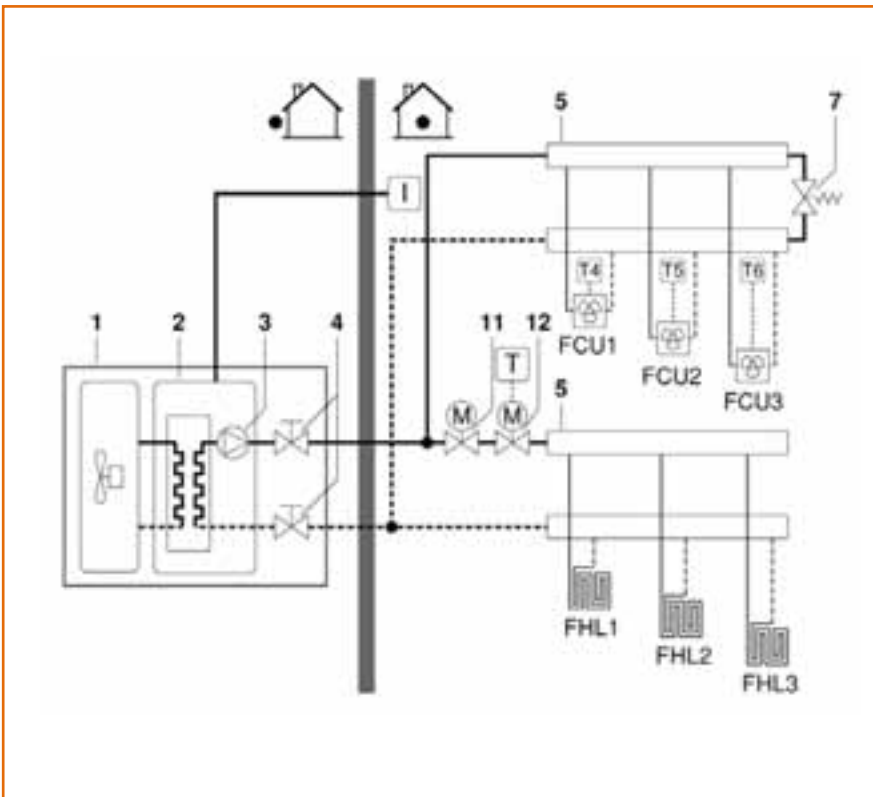

1. Unit
2. Heat exchanger
3. Pump
4. Shut-off valve
5. Collector (field supply)
6. By-pass valve (field supply)
11. Motorized 2-way valve to shut off the floor heating loops during cooling operation (field supply)
12. Motorized 2-way valve for activation of the room thermostat (field supply)

- FCU1...3 Fan coil unit with thermostat (field supply)  
 FHL1...3 Floor heating loop (field supply)  
 T Heating only room thermostat (field supply)  
 T4..6 Individual room thermostat for fan coil heated/cooled room (field supply)  
 I User interface

## OUTDOOR SPLIT TYPE



OUTDOOR UNIT			ERLQ018BAVJU	ERLQ024BAVJU	ERLQ030BAVJU	ERLQ036BAVJU	ERLQ048BAVJU	ERLQ054BAVJU	
Nominal capacity (1)	Heating	Btu/hr	19,620	23,340	28,760	38,200	47,800	54,600	
	Cooling	Btu/hr	24,570	27,840	28,560	47,600	59,100	60,600	
Nominal input (1)	Heating	kW	1.35	1.66	2.21	2.58	3.30	3.97	
	Cooling	kW	2.36	2.87	3.06	3.91	5.94	6.94	
COP			4.25	4.12	3.81	4.34	4.24	4.03	
EER			10.41	9.7	9.33	12.17	9.95	8.73	
Fan	Motor	Model	Brushless DC motor			Brushless DC motor			
		Output	W			70			
Operation range	Heating	°F (°C)	-4 - 77 (-20 - 25)			-4 - 95 (-20 - 35)			
	Cooling	°F (°C)	50 - 110 (10 - 43)			50 - 114.8 (10 - 46)			
	Domestic water	°F (°C)	-4 - 110 (-20 - 43)*			-4 - 109.4* (-20 - 43)			
Sound power level	Heating	dBA	61	61	62	64	64	66	
	Cooling	dBA	63	63	63	64	66	69	
Sound pressure level	Heating	dBA	48	48	49	49	51	53	
	Cooling	dBA	48	48	50	50	52	54	
Air Flow Rate (nominal at 230V) (cfm)	Heating	m³/min	N/A	N/A	N/A	3178	3178	3178	
	Cooling	m³/min	N/A	N/A	N/A	3390	3531	3425	
Piping connections	Liquid (OD)	Type	Flare connection			Flare connection			
		Diameter (OD)	in.	ø 1/4	ø 1/4	ø 1/4	ø 3/8	ø 3/8	ø 3/8
	Gas	Type	Flare connection			Flare connection			
		Diameter (OD)	in.	ø 5/8	ø 5/8	ø 5/8	ø 5/8	ø 5/8	ø 5/8
	Drain	Type	Socket			Hole			
		Diameter (OD)	in.	ø 7/10	ø 7/10	ø 7/10	ø 1	ø 1	ø 1
	Piping Length	Minimum	ft.	10	10	10	16.4	16.4	16.4
		Maximum	ft.	98	98	98	246	246	246
		Equivalent	ft.	-	-	-	312	312	312
		Chargeless	ft.	33	33	33	98.4	98.4	98.4
	Installation Height Difference	Maximum	ft.	66	66	66	98.4	98.4	98.4
		Refrigerant charge	Charge	R-410A			R-410A		
Refrigerant charge	Additional	lbs.	3.75			8.15			
		oz./ft.	0.21			Refer to chart in installation instructions			
Power supply			208-230V/1Ph/60Hz			208-230V/1Ph/60Hz			
Minimum Circuit Amps (MCA)		A	18	18	18	26.5	26.5	26.5	
Maximum Overcurrent Protection (MOP)		A	20	20	20	30	30	30	
Dimensions (Net)		HxWxD	in. 28 9/10 x 32 1/2 x 11 8/10			46 1/16 x 35 7/16 x 12 5/8			
Weight	Net	lbs.	123	123	123	227	227	227	
	Gross	lbs.	134	134	134	251.3	251.3	251.3	

Measuring conditions: Heating Ta DB/WB 44.6°F/42.8°F (7/6°C) - LWC 95°F (35°C) (DT=9°F (5°C))

- Cooling Ta 95°F (35°C) - LWE 64.4°F (18°C) (DT=9°F (5°C))

\* Booster heater operation from 95°F (35°C) onwards

(1) These conditions are based on under floor heating/cooling application

## OUTDOOR MONOBLOC TYPE



OUTDOOR UNIT			HEATING ONLY			REVERSIBLE		
SINGLE PHASE	With bottom plate heater		EDLQ036BA6VJU	EDLQ048BA6VJU	EDLQ054BA6VJU	EBLQ036BA6VJU	EBLQ048BA6VJU	EBLQ054BA6VJU
Nominal capacity (3)	Heating	Btu/hr	38,200	47,700	54,600	38,200	47,700	54,600
	Cooling	Btu/hr	-	-	-	43,800	54,500	57,000
Nominal input (3)	Heating	kW	2.47	3.2	3.78	7.47	3.2	3.79
	Cooling	kW	-	-	-	3.78	5.65	6.28
COP			4.54	4.37	4.22	4.54	4.37	4.22
EER			-	-	-	11.5	9.65	9.1
Operation range	Heating	°F (°C)	5 - 95 <sup>(1)</sup> (-15 - 35)			5 - 95 <sup>(1)</sup> (-15 - 35)		
	Cooling	°F (°C)	-			50 - 114.8 (10 - 46)		
	Domestic water	°F (°C)	5 - 95 <sup>(1)(2)</sup> (-15 - 35)			5 - 95 <sup>(1)(2)</sup> (-15 - 35)		
Sound power level	Heating	dBA	64	64	66	64	64	66
	Cooling	dBA	-	-	-	65	66	69
Sound pressure level	Heating	dBA	51	51	52	51	51	52
	Cooling	dBA	-	-	-	50	52	54
Refrigerant charge		R-410A	lbs. 6.5			6.5		
Power supply			208-230V/1Ph/60Hz			208-230V/1Ph/60Hz		
Maximum Overcurrent Protection (MOP)		A	30			30		
Dimensions (Net)		HxWxD	in. 55 27/32 x 56 1/2 x 15 1/32			55 27/32 x 56 1/2 x 15 1/32		
Weight	Net	lbs.	397			397		
	Gross	lbs.	441			441		

Measuring conditions: Heating Ta DB/WB 44.6°F/42.8°F (7/6°C) - LWC 95°F (35°C) - Cooling Ta 95°F (35°C) - LWE 64.4°F (18°C)

(1) E(D/B)L\* models can reach -4°F (-20°C) but without capacity guarantee

(2) Booster heater operation from 95°F (35°C) onwards

(3) These conditions are based on under floor heating/cooling application

(4) For further information pertaining to the hydronic specs of the MonoBloc system, refer to the engineering databook

# HYDROBOX (FOR USE WITH ERLQ018/024/030BVJU)



## HYDROBOX

			EKHBH030BA3VJU	EKHBX030BA3VJU	EKHBH030B6VJU	EKHBX030B6VJU
Function			Heating only		Reversible	
Leaving water temperature range	Heating	°F (°C)	(59) 77 - 131* ((15) 25 - 55)			
	Cooling	°F (°C)	-		41 - 71.6 (122) (5 - 22 (50))	
Drain valve			Yes			
Material			Epoxy polyester painted galvanized steel			
Color			Neutral white (RAL 9010)			
Dimensions (Net)	HxWxD	in.	36 5/16 x 19 3/4 x 14 7/32		36 5/16 x 19 3/4 x 14 7/32	
	Net	lbs.	101		101	
Weight	Gross	lbs.	130		130	
	Capacity	kW	3		6	
Factory mounted heater	Capacity Steps		1		2	
	Max Overcurrent Protection (MOP)		20 A		30 A	
	Minimum Circuit Amps (MCA)		14.3 A		28.6 A	
	Power supply		208-230V/1Ph/60Hz		208-230V/1Ph/60Hz	
				208-230V/1Ph/60Hz		208-230V/1Ph/60Hz

When connected to all outdoor units	Main components	Expansion vessel	Volume	gal.	2.64		
			Max. water pressure	PSI	43.5		
Water circuit	Piping connections diameter	Safety valve	Pre Pressure	PSI	14.5		
			Piping	in.	1" Male BSP		
			Piping	in.	1		
			Safety valve	PSI	43.5		
			Total water volume	gal.	5.5		
Refrigerant circuit	Gas side diameter	Liquid side diameter	in.	ø 5/8			
			in.	ø 1/4			
Operation range	Waterside	Heating	°F (°C)	(59) 77 - 131* ((15) 25 - 55)			
		Cooling	°F (°C)	-			
When connected to ERLQ018	Main components	Pump	Nominal ESP unit	Heating	PSI	7.1	
			Cooling	PSI	-		
		Water side Heat exchanger	Water volume	gal.	0.18		
			Water flow rate Min./Max	GPM	3.17/11.09		
			Water flow rate Nom.	Heating	GPM	4.35	
				Cooling	GPM	-	
When connected to ERLQ024	Main components	Pump	Nominal ESP unit	Heating	PSI	6.5	
			Cooling	PSI	-		
		Water side Heat exchanger	Water volume	gal.	0.18		
			Water flow rate Min./Max	GPM	3.17/11.09		
			Water flow rate Nom.	Heating	GPM	5.18	
				Cooling	GPM	-	
When connected to ERLQ030	Main components	Pump	Nominal ESP unit	Heating	PSI	5.5	
			Cooling	PSI	-		
		Water side Heat exchanger	Water volume	gal.	0.18		
			Water flow rate Min./Max	GPM	3.17/11.09		
			Water flow rate Nom.	Heating	GPM	6.37	
				Cooling	GPM	-	

\*Back up heater operation between 59°F (15°C) and 77°F (25°C)

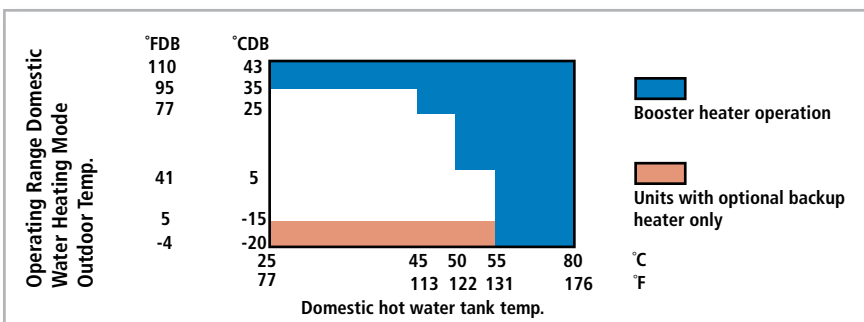
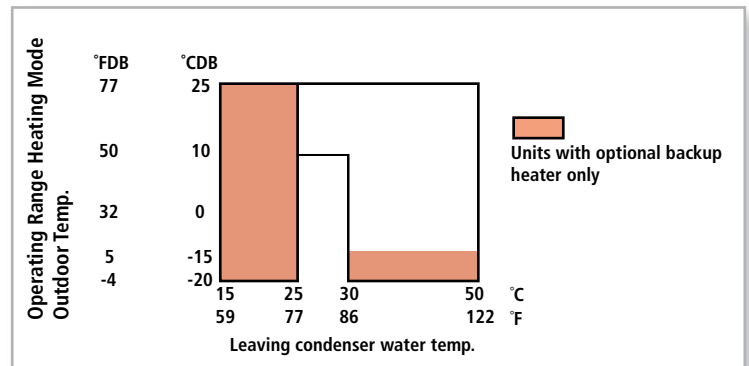
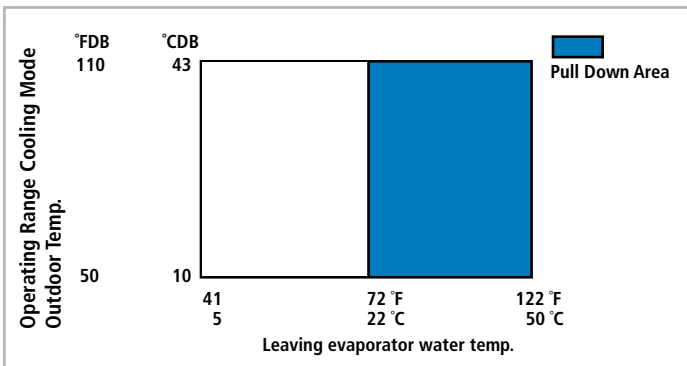

# HYDROBOX (FOR USE WITH ERLQ036/048/054BVJU)



## HYDROBOX

HYDROBOX			EKHBH054BA3VJU	EKHBX054BA3VJU	EKHBH054B6VJU	EKHBX054B6VJU
Function			Heating only		Reversible	
Leaving water temperature range	Heating	°F (°C)	(59) 77 - 131* ((15) 25 - 55)		(59) 77 - 131* ((15) 25 - 55)	
	Cooling	°F (°C)	-		41 - 71.6 (5 - 22)	
Drain valve			yes			
Material			Epoxy polyester painted galvanized steel			
Color			Neutral white (RAL 9010)			
Dimensions (Net)	HxWxD	in.	36 5/16 x 19 3/4 x 14 7/32		36 5/16 x 19 3/4 x 14 7/32	
	Net	lbs.	123		123	
Weight	Gross	lbs.	152		152	
	Capacity	kw	3		6	
Factory mounted heater	Capacity Steps		1		2	
	Max Overcurrent Protection (MOP)		20 A		30 A	
	Minimum Circuit Amps (MCA)		14.3 A		28.6 A	
	Power supply		208-230V/1Ph/60Hz		208-230V/1Ph/60Hz	
			208-230V/1Ph/60Hz		208-230V/1Ph/60Hz	

When connected to all outdoor units	Main components	Expansion vessel	Volume	gal.	2.64	2.64		
When connected to all outdoor units	Water circuit	Max. water pressure	PSI	43.5	43.5	43.5		
		Pre Pressure	PSI	14.5	14.5	14.5		
		Piping connections diameter	in.	1 1/4 Male BSP	1 1/4 Male BSP	1 1/4 Male BSP		
	Refrigerant circuit	Piping	in.	1 1/4	1 1/4	1 1/4		
		Safety valve	PSI	43.5	43.5	43.5		
		Total water volume	gal.	1.45	1.45	1.45		
	Operation range	Waterside	Gas side diameter	in.	ø 5/8	ø 5/8	ø 5/8	
			Liquid side diameter	in.	ø 3/8	ø 3/8	ø 3/8	
	When connected to ERLQ036	Main components	Pump	Nominal ESP unit	Heating	PSI	7.6	7.6
				Cooling	PSI	-	8.1	-
Water side Heat exchanger		Water volume	gal.	0.26	0.26	0.26		
		Water flow rate Min./Max	GPM	4.23/15.32	4.23/15.32	4.23/15.32		
		Water flow rate Nom.	Heating	GPM	8.48	8.48	8.48	
			Cooling	GPM	-	7.58	-	7.58
When connected to ERLQ048		Main components	Pump	Nominal ESP unit	Heating	PSI	6.3	6.3
				Cooling	PSI	-	7.1	-
		Water side Heat exchanger	Water volume	gal.	0.26	0.26	0.26	
			Water flow rate Min./Max	GPM	4.23/15.32	4.23/15.32	4.23/15.32	
	Water flow rate Nom.		Heating	GPM	10.59	10.59	10.59	
			Cooling	GPM	-	9.46	-	9.46
	When connected to ERLQ054	Main components	Pump	Nominal ESP unit	Heating	PSI	5.08	5.08
				Cooling	PSI	-	6.79	-
		Water side Heat exchanger	Water volume	gal.	0.26	0.26	0.26	
			Water flow rate Min./Max	GPM	4.23/15.32	4.23/15.32	4.23/15.32	
Water flow rate Nom.			Heating	GPM	12.13	12.13	12.13	
			Cooling	GPM	-	9.93	-	9.93

\*Back up heater operation between 59°F (15°C) and 77°F (25°C)

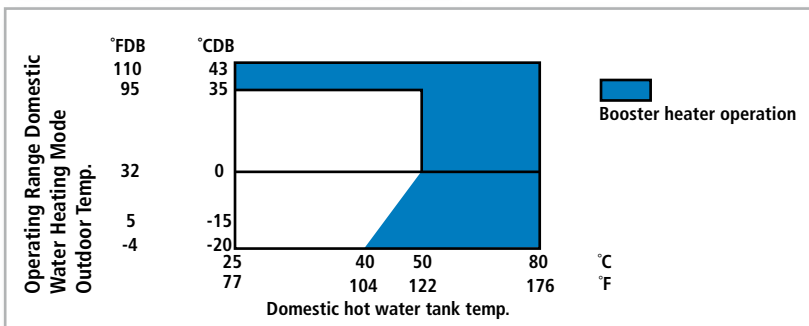
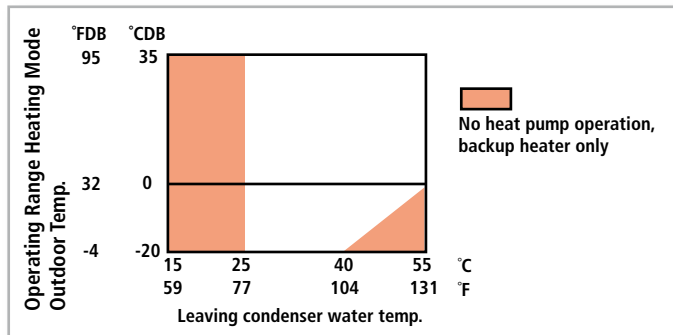
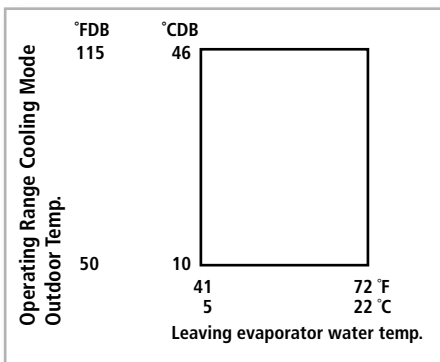

## DOMESTIC HOT WATER TANK



		EKHS050BA3VJU	EKHS080BA3VJU
Water volume	gal.	52.8	79.2
Max. water temperature	°F (°C)	185 (85)	
Max. water pressure	PSI	145	
Insulation (Polyurethane foam) Min. thickness	in.	1 5/8	
Height	in.	45 3/8	63
Diameter	in.	22 7/8	
Booster heater	kW	3	
Piping connections	Water inlet H/E Diameter	in. ø 3/4 FBSP	
	Water outlet H/E Diameter	in. ø 3/4 FBSP	
	Cold water in Diameter	in. ø 3/4 FBSP	
	Hot water out Diameter	in. ø 3/4 FBSP	
Minimum Circuit Amps (MCA)	A	14.3	
Maximum Overcurrent Protection (MOP)	A	20	
Power supply		208-230V/1Ph/60Hz	
Material inside tank		Stainless steel (DIN 1.4521) - 316L	
Material outside casing		Epoxy-coated mild steel	
Color		Neutral white	
Dimensions (Net)	HxWxD	in. 45 9/32 x 22 27/32 x 22 27/32	63 x 22 27/32 x 22 27/32
Empty weight	lbs.	99	129.8

Note: 3-Way Valve is factory included with the Domestic Hot Water Tank for field installation

## SOLAR KIT



		EKSOLHWBAVJU	
Heat exchanger	pressure drop	psi	3.12
	max. inlet temp	°F (°C)	230 (110)
	heat exchange capacity	W/K	1,400
	Logarithmic mean temperature difference (LMTD)	K	5
Pump	Number of speeds		3
	Power input	W	46
Water circuit	Piping connections diameter	in.	3/4 FBSP
	max.	°F	95 (35)
Ambient temperature	min.	°F	33.8 (1)
	Power supply		208-230V/1Ph/60Hz
Power supply intake		from indoor unit	
Dimensions (Net)	HxWxD	in.	30 1/32 x 12 x 10 1/32

## SOLAR COLLECTOR



		EKSV26P-U	EKSH26P-U
Position		Vertical	Horizontal
Outer surface	sq. ft.	28	28
Absorber surface	sq. ft.	25.4	25.4
Water content	gal.	0.45	0.55
Absorber		Harp-shaped copper pipe register with laser-welded highly selective coated aluminum plate	
Coating		Micro-therm (absorption max. 96%, emission ca. 5% +/-2%)	
Glazing		Single pane safety glass, transmission +/-92%	
Heat insulation		Mineral wool, 2 in.	
Max. pressure drop at 26.4g/hr.	PSI	0.04	0.007
Allowed roof angle		15° to 80°	15° to 80°
Max. standstill temperature	°F (°C)	392 (200)	392 (200)
Max. operating pressure	PSI	87	87
Dimensions (Net)	HxWxD	in. 78 7/10 x 51 2/10 x 3 4/10	51 2/10 x 78 7/10 x 3 4/10
Weight	lbs.	92.5	92.5

## SOLAR THERMAL - OPTION LIST

Flow Sensor	EKSFLP12A
	EKSRCF
Pipe mounting kits	EKSFIXVBP
	EKSCONLCP
	EKSFIXMP130
	EKSFIXMP200
	EKSFIXAD
On-roof mounting kits	EKSFIXADP
	EKSFIXADS
	EKSFIXWD
	EKSFXBD
Glycol fluid	EKSGFL

## PUMP STATION



			EKSRDS1A-U WITH CONTROLLER EKSR3PA
Mounting Method			On wall
Power Supply			120V/1Ph/60Hz
Control			Digital temperature difference controller with plain text
Max. electric power consumption of the control unit	W		2
Solar panel temperature sensor			Pt1000
Storage tank sensor			PTC
Return flow sensor			PTC
Feed temperature and flow sensor (option)			Voltage signal (3.5V DC)
Dimensions (Net)	HxWxD	in.	13 1/10 x 9 1/10 x 5 7/10
Weight (Net)		lbs.	N/A

## ROOM THERMOSTAT



thermostat

			EKRTWA
Ambient temperature	Storage	°F (°C)	-4 - 140 (-20 - 60)
	Operation	°F (°C)	32 - 122 (0 - 50)
Temperature setpoint range	Heating	°F (°C)	39.2 - 98.6 (4 - 37)
	Cooling	°F (°C)	39.2 - 98.6 (4 - 37)
Clock			yes
Regulation function			proportional band
Dimensions (Net)	HxWxD	in.	3 27/64 x 4 59/64 x 1 11/32
Weight (Net)		lbs.	0.47

## OPTION LIST

	MODEL NUMBER	NOTES
Condensate Kit	EKHBDP	For Cooling Mode Applications
Digital I/O PCB	EKRPIHBAAU	Unit On/Off Alarm On/Off Solar Input
BSP to NPT Connection Adaptors	DACA-DHWRA-1	DHW Recirculation Loop 1/2"
	DACA-DHWTA-1	DHW Tank Inlet/Outlet 3/4"
	DACA-THXA-1	DHW He-Ex 1"
	DACA-3WVTA-1	3-Way Valve 1 1/4"
	DACA-3WVTA-2	3-Way Valve 1"
	DACA-HBA-1	Hydrobox Inlet/Outlet 1 1/4"
	DACA-MP-1	DHW Tank Plug 3/4"
Pre-Insulated Line Sets (Applicable to ERLQ018/024/030BA Units Only)	DACA-RA3-10-1	1/4" x 5/8" (10 ft. Length)
	DACA-RA3-15-1	1/4" x 5/8" (15 ft. Length)
	DACA-RA3-30-1	1/4" x 5/8" (30 ft. Length)
	DACA-RA3-50-1	1/4" x 5/8" (50 ft. Length)
	DACA-RA3-65-1	1/4" x 5/8" (65 ft. Length)
	DACA-RA3-100-1	1/4" x 5/8" (100 ft. Length)
Wall Mounting Bracket for Consensing Unit	DACA-WB-3	Unit Weight - Up to 500 lbs.



**↗ DID YOU KNOW...**

with a Daikin Altherma™ heat pump, the temperature of the domestic water can go up to 185°F (85°C), the temperature of the hot water for heating ranges between 59°F (15°C) and 131°F (55°C) and the temperature of the cold water for cooling between 41°F (5°C) and 72°F (22.2°C).

**Control customized to your customer**

The water temperature changes in function with the outside temperature so that your customer can enjoy a stable level of heating at any time. As the installer, you set up the system according to the desires of your customer. You input four temperatures to determine the “heating curve” and in doing so, you perfectly tune the Daikin Altherma™ system to the type of home.

**Automatic re-start after power interruption**

In the event of a power interruption of up to two hours, the system automatically resumes with the previously set parameters.

**Quiet operation**

The outdoor unit makes hardly any noise thereby leaving your customer’s (and the neighbor’s) peace and quiet undisturbed. You can even set the outdoor unit to produce 10dB(A) less noise during the night.

**Electric back-up heating**

Every Daikin Altherma™ system is equipped with a back-up heater (heating capacity of 3 or 6 kW). This unit can be used for supplemental heating during extremely cold outdoor temperatures or as a back-up in case of any problems with the outdoor unit. Your customer can then enjoy comfortable heating at any moment.

The operation of the back-up heater can be coupled to the outside temperature. The back-up heater will then only operate when outside temperatures are extremely low.

Daikin Altherma’s “simulator” software program allows quick and easy indication of the benefits of a Daikin Altherma™ system.

By specifying a number of parameters such as the location, the surface area to be heated, the required heating capacity, the entry and exit water temperatures of the distribution network and the local energy prices, the program displays the following simulation details.

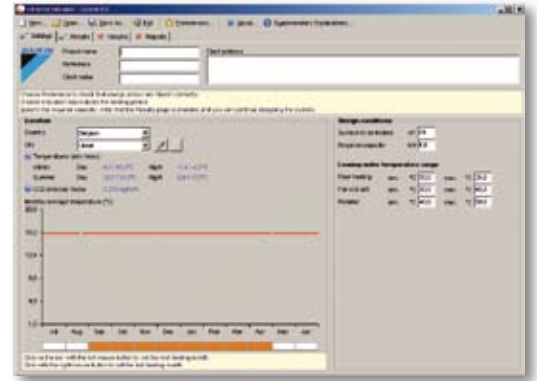

1. Material list with technical specification
2. Simulation graphics:
  - a) Required and available heating capacity with indication of the SPF (or Seasonal COP)
  - b) Duration of the heating period as a function of the outside temperature
  - c) The annual energy cost compared with a heating system using gas or fuel oil
  - d) The annual amount CO<sub>2</sub> emitted in tonnes compared with a heating system using gas or fuel oil
  - e) The monthly energy consumption in kWh
  - f) The monthly energy cost in dollars
  - g) The total amount of thermal energy in kWh as a function of the outside temperature
  - h) The radiated heat per ft<sup>2</sup> (in Btu/ft<sup>2</sup>) per month

All data is collected in a separate report. If you are interested in this software, contact your local Daikin Altherma™ distributor

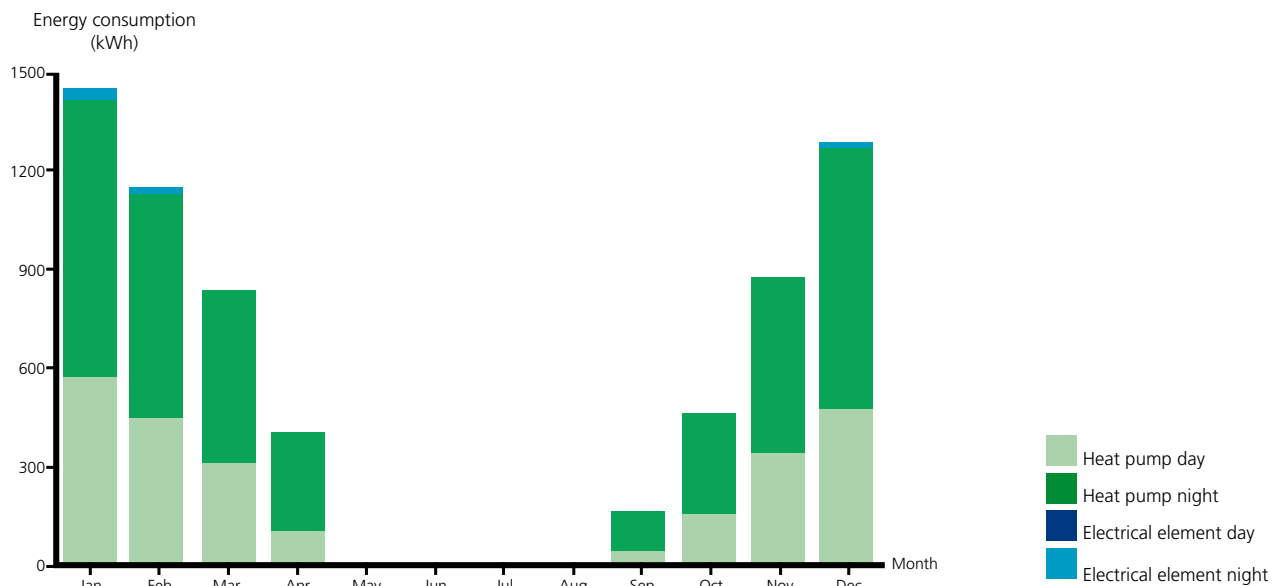

# OTHER PRODUCT LINES AVAILABLE

## Single Split Systems

SEER	18					15+					13					13									
Capacity	9kBtu/h					12kBtu/h					15kBtu/h					18kBtu/h					24kBtu/h				
Recommended Maximum Room size	450 sq. ft.					625 sq. ft.					813 sq. ft.					1,050 sq. ft.					1,460 sq. ft.				

For reference use only. Equipment selection should always be based on detailed load calculations.

## Quaternity™ System

SEER	21+		
Capacity	9kBtu/h	12kBtu/h	15kBtu/h
Recommended Maximum Room size	450 sq. ft.	625 sq. ft.	813 sq. ft.

For reference use only. Equipment selection should always be based on detailed load calculations.

## Multi-Split Systems

SEER	Up to 19.5							Up to 17.2							Up to 16.6									
Capacity	7k/9kBtu/h		12kBtu/h		15kBtu/h		18kBtu/h		24kBtu/h		32kBtu/h		7k/9kBtu/h		12kBtu/h		15kBtu/h		18kBtu/h		24kBtu/h		32kBtu/h	
Recommended Maximum Room size	450 sq. ft.		625 sq. ft.		813 sq. ft.		1,050 sq. ft.		1,460 sq. ft.		2,080 sq. ft.		450 sq. ft.		625 sq. ft.		813 sq. ft.		1,050 sq. ft.		1,460 sq. ft.		2,080 sq. ft.	

For reference use only. Equipment selection should always be based on detailed load calculations.

## SkyAir Systems

SEER	17					13				
Capacity	18kBtu/h		24kBtu/h		30kBtu/h		36kBtu/h		42kBtu/h	
Recommended Maximum Room size	1,050 sq. ft.		1,460 sq. ft.		1,875 sq. ft.		2,370 sq. ft.		2,800 sq. ft.	

For reference use only. Equipment selection should always be based on detailed load calculations.

## Daikin Inverter Ducted System

- Energy efficient for residential ducted applications (SEER up to 18.15, HSPF up to 8.92)
- Quiet operation
- Electric heater options
- Auto fan allows unit to cycle on and off with the load
- ECM Fan Motor



## VRV III-S System

- Available in 3 and 4-Ton, 208-230V/60Hz/1ph
- Individual zone control
- Can operate up to 6 or 8 fan coil units
- Energy efficient for light commercial and residential applications
- Innovative space-saving design
- Reliability
- Outstanding warranties
- 11 types of indoor units available in 51 models with ducted and duct-free options

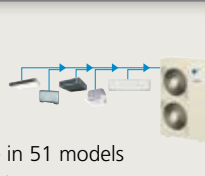



## WARNINGS

- Always use a licensed installer or contractor to install this product. Improper installation can result in water or refrigerant leakage, electrical shock, fire or explosion.
- Use only those parts and accessories supplied or specified by Daikin. Ask a licensed contractor to install those parts and accessories. Use of unauthorized parts and accessories or improper installation of parts and accessories can result in water or refrigerant leakage, electrical shock, fire or explosion.
- Read the User's Manual carefully before using this product. The User's Manual provides important safety instructions and warnings. Be sure to follow these instructions and warnings.

For any inquiries, contact your local Daikin sales office.



Daikin Europe N.V. is approved by LRQA for its Quality Management System in accordance with the ISO9001 standard. ISO9001 pertains to quality assurance regarding design, development, manufacturing as well as to services related to the product.



ISO14001 assures an effective environmental management system in order to help protect human health and the environment from the potential impact of our activities, products and services and to assist in maintaining and improving the quality of the environment.



© 2010 Daikin Industries, Limited.

Daikin®, Daikin AC Absolute Comfort®, its design, and Daikin Altherma™ are registered trademarks of Daikin Industries, Limited. All rights reserved.



Daikin AC (Americas), Inc.  
 1645 Wallace Drive, Suite 110  
 Carrollton, TX 75006 USA  
[www.daikinac.com/altherma](http://www.daikinac.com/altherma)  
 866-4DAIKIN  
 972-245-1510

Dealer Information

PCAWUSE10-08B

Daikin's products are subject to continuous improvements. Daikin reserves the right to modify product design, specifications and information in this brochure without notice and without incurring any obligations.