



# Submittal Data Information

## HD-25

#SS-6.1-1

Effective: October 8, 2010

Job: \_\_\_\_\_ Engineer: \_\_\_\_\_ Contractor: \_\_\_\_\_ Rep: \_\_\_\_\_

### Applications

The Apricus HD-25 is an air to water radiator designed to dissipate the energy produced by one AP-30 collector. Heat dissipation may be necessary when solar thermal systems are designed for space heating applications which may produce more energy than is demanded during warmer seasons.

### Materials of Construction

Piping: Copper (Ag-Zn-Cu brazed)  
Heat Transfer Fins: 3A21 Grade Aluminum  
Casing: 3A21 Grade Aluminum

### Dimensions

Height: 500mm / 19.7"  
Depth: 172mm / 6.77"  
Width: 375mm / 14.7"  
Heat Transfer Area: 2.8 m<sup>2</sup> / 30.1 ft<sup>2</sup>  
Gross Weight: 6.6 kg / 13.2 lbs  
Inlet/Outlet Pipe: ø0.59" x 0.04" / ø15 mm x 1.0mm



### Heat Loss Performance

When  $\Delta T = 40^{\circ}\text{C} / 70^{\circ}\text{F}$ , heat dissipation  $\geq 1.3\text{kW} / 4435 \text{ btu}$ .  
For optimal performance ensure good natural air circulation.

### Installation Guidelines

Max Flow Range: 15L/min / 3.96 GPM  
Ideal Location: Good natural air flow  
Heat Transfer Liquid: Water  
Propylene Glycol ( $\leq 50\%$ )  
Glycerine

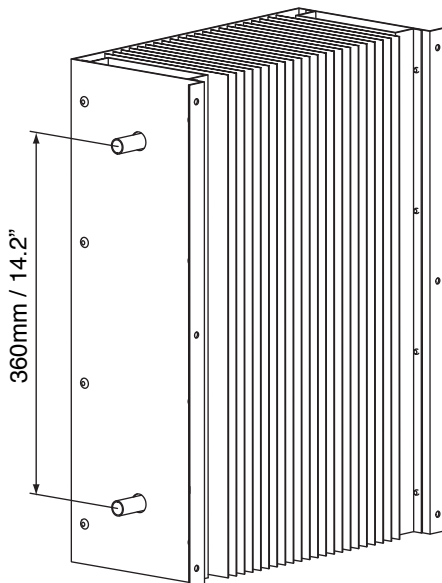
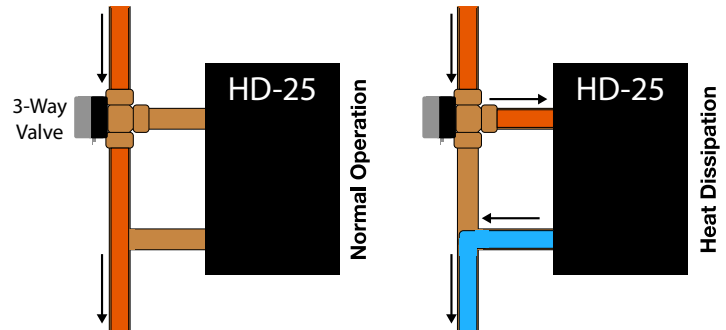

Pressure Drop Graph

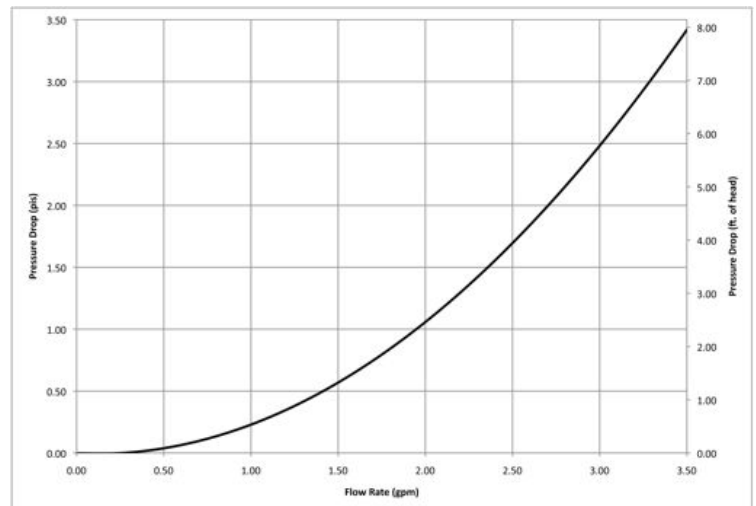

**Sustainable HOT WATER Solutions, Delivered by APRICUS**

6 Sycamore Way, Branford, Connecticut 06405 USA Ph: 203-488-8215 Fax: 203-488-8572  
office-usa@apricus.com www.apricus.com