

# *iSolar™ Plus*

**Mounting**

**Connection**

**Application examples**

**Operation**

**Troubleshooting**



49011110

**Thank you for buying this product.**

**Read this manual carefully to get the best performance from this unit.**

**Please keep this manual carefully.**

## Contents

<b>General</b> .....	<b>2</b>	System layout 8.....	24
<b>Overview</b> .....	<b>3</b>	System-specific functions .....	26
<b>1. Installation</b> .....	<b>4</b>	System layout 9.....	28
1.1 Mounting .....	4	System layout 10 .....	30
1.2 Electrical connection.....	4	<b>2. Operation and function</b> .....	<b>32</b>
1.3 Data communication/ Bus .....	5	2.1 Push buttons.....	32
1.4 Terminal allocation in the different system layouts ....	6	2.2 System monitoring display .....	32
System layout 1 .....	6	2.3 Flashing codes .....	33
System layout 2.....	8	<b>3. Commissioning</b> .....	<b>34</b>
System-specific functions .....	10	<b>4. Channel overview</b> .....	<b>37</b>
System layout 3.....	12	4.1 Display channels .....	37
System-specific functions .....	14	4.2 Adjustment channels .....	39
System layout 4.....	16	<b>5. Troubleshooting</b> .....	<b>47</b>
System layout 5.....	18	5.1 Various:.....	48
System layout 6.....	20	<b>6. Accessories</b> .....	<b>50</b>
System layout 7.....	22	<b>Impressum</b> .....	<b>52</b>

## General

### Safety advice:

Please read the following information carefully before installing and operating the controller. In this way damage to the solar system caused by wrong installation will be avoided. Please make sure that the mounting is adapted to the characteristics of the building, that the local regulations are respected and is conform with the technical rules.

Please pay attention to the following safety advice in order to avoid danger and damage to people and property.

Subject to technical change. Errors excepted.

### Instructions:

Attention should be paid to

- valid national and local standards and regulations
- respective valid standards and directives

Equipment to be installed and used in accordance with the rules of the National Electrical Code (NEC) or with Canadian Electrical Code (CEC), Part I.

These instructions are exclusively addressed to authorized skilled personnel.

- Only qualified electricians should carry out installation and maintenance work.
- Initial installation should be carried out by qualified personnel

## Description of symbols

<b>WARNING!</b>	<p><b>Warnings are indicated with a warning triangle!</b>  <b>They contain information on how to avoid the danger described.</b></p>
	

Signal words describe the danger that may occur, when it is not avoided.

**Warning** means that injury, possibly life-threatening injury, can occur.

**Attention** means that damage to the appliance can occur.



### Note

Notes are indicated with an information symbol.

➔ Arrows indicate instruction steps that should be carried out.

## Information about the product

### Proper usage

The solar controller is designed for use in solar thermal and heating systems in compliance with the technical data specified in these instructions.

Improper use excludes all liability claims.



### Note

Strong electromagnetic fields can impair the function of the controller.

➔ Make sure the controller as well as the system are not exposed to strong electromagnetic fields.

## Overview

- System-monitoring-display
- Up to 4 Pt1000 temperature sensors
- 2 semiconductor relays for pump speed control
- 10 basic system layouts to choose from
- Energy metering
- VBus®
- Function control
- Thermostat function (time controlled)
- Control of the system by ServiceCenter software possible
- User-friendly operation
- Housing with outstanding design
- Extra-low power consumption



### Included with the iSOLAR PLUS:

- 1 × iSOLAR PLUS
- 1 × accessory bag
  - 1 × spare fuse T4A
  - 2 × screws and wall plugs
  - 4 × strain relief and screws
- 1 × manual

### Additionally enclosed in the full kit:

- 2 × sensor FKP6
- 2 × sensor FRP6

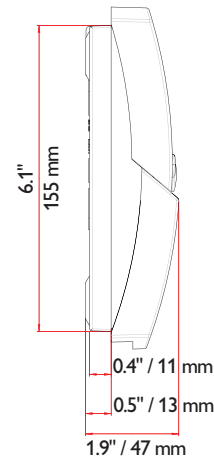
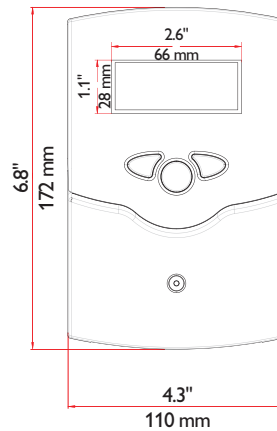

### Technical data

**Housing:** plastic, PC-ABS and PMMA

**Protection type:** IP 20 / EN 60529

**Ambient temp.:**

32 ... 104 °F

[0 ... 40 °C]

**Size:**

6.8" × 4.3" × 1.9"

172 × 110 × 46 mm

**Mounting:** wall mounting, mounting into patch-panels is possible

**Display:** System screen for system visualization, 16-segment display, 7-segment display, 8 symbols for system status and operating control lamp

**Operation:** by 3 push buttons at the front of the housing

**Functions:** Differential temperature controller with optional add-on system functions. Function control, operating hours counter for solar pump, evacuated tube collector function, pump speed control, thermostat function, drainback and booster option, and energy metering.

**Inputs:**

for 4 Pt1000 temperature sensors

**Outputs:** 2 semiconductor relays

**Bus:** VBus®

**Power supply:**

100 ... 240 V~

**Standby power consumption:**

< 1 W

**Switching capacities:**

R1: 1 (1) A 100 ... 240 V~  
(semiconductor relay)

R2: 1 (1) A 100 ... 240 V~  
(semiconductor relay)

# 1. Installation

## 1.1 Mounting

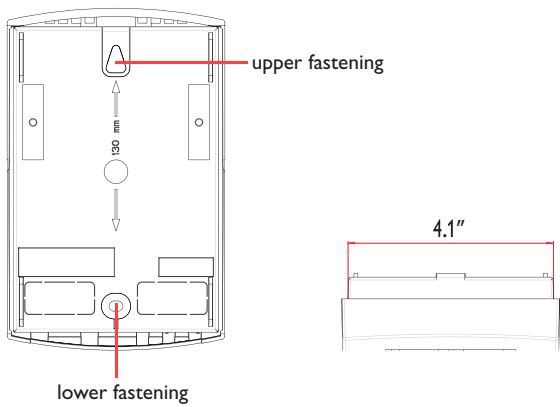
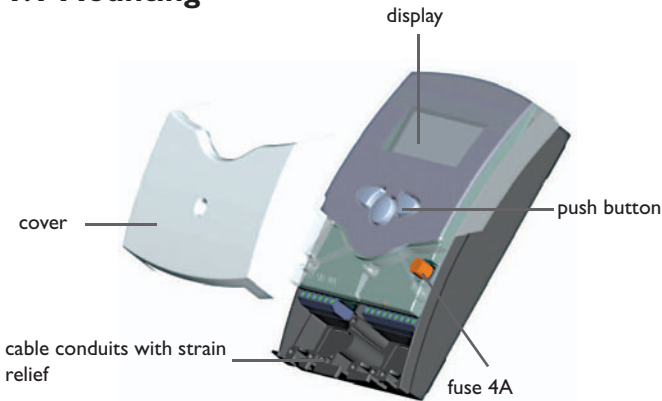

	<b>WARNING!</b> Electric shock!
	Opening the housing will expose live parts! → Switch off power supply and disconnect the device from power supply before opening the housing!

- The unit must only be installed
- in a dry interior location
  - in a non-hazardous location
  - away from electromagnetic fields

The controller must additionally be supplied from a double-pole switch with contact gap of at least 0.12".

- Route sensor cables and power supply cables separately.
- Unscrew the cross-head screw from the cover and remove it along with the cover from the housing
  - Mark the upper fastening point on the wall and drill
  - Fasten the enclosed wall plug and screw leaving the head protruding
  - Hang the housing from the upper fastening point and mark the lower fastening point through the hole in the terminal box (centers 5.1")
  - Drill and insert the lower wall plug
  - Fasten the housing to the wall with lower fastening screw and tighten
  - Complete wiring connections in accordance with terminal allocations, see chap. 1.2 "Electrical connection"
  - Place the cover back onto the housing
  - Fasten the cover by means of the cross-head screw

## 1.2 Electrical connection

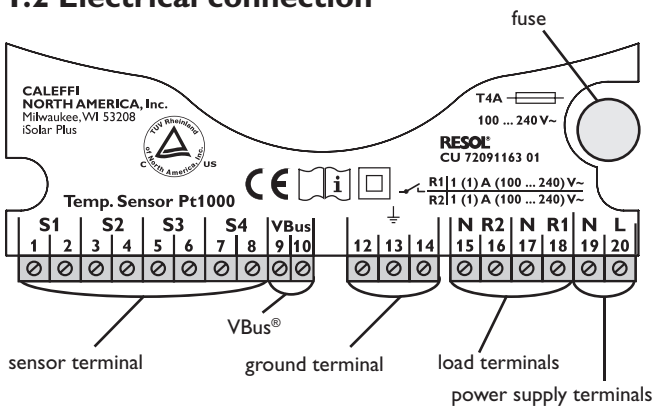

	<b>ATTENTION!</b> ESD damage!
	Electrostatic discharge can lead to damage to electronic components! → Take care to discharge properly before touching the inside of the device. To do so, touch a grounded surface such as a radiator or tap!

**Note:**  
The minimum pump speed must be set to 100 % when auxiliary relays or valves are connected.

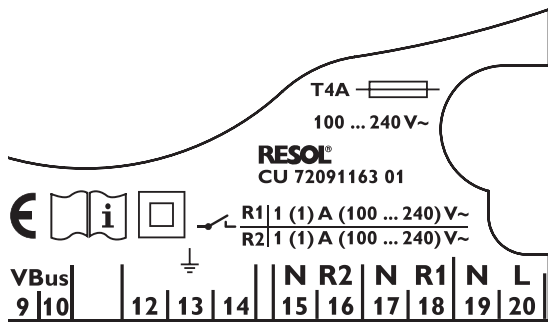

Grounding and load terminals

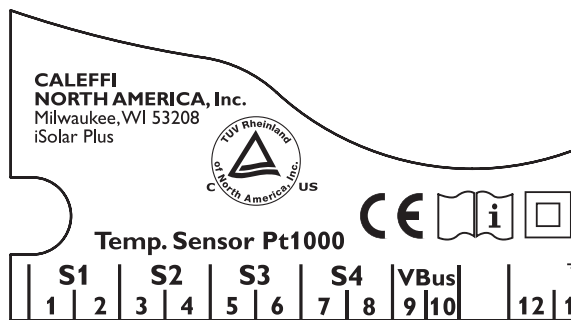

Sensor terminals S1 ... S4

### 1.3 Data communication/ Bus

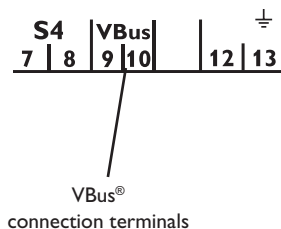

Connecting the device to the power supply must always be the last step of the installation!

The power supply to the controller must be carried out via an external power switch (last step!). The supply voltage must be 100 ... 240 V~ (50 ... 60 Hz). Flexible cables must be attached to the housing with the enclosed strain relief and the corresponding screws.

The controller is equipped with two semiconductor relays, to which **loads** such as pumps, valves etc. can be connected:

- Relay 1
  - 18 = conductor R1
  - 17 = neutral conductor N
  - 13 = ground conductor
- Relay 2
  - 16 = conductor R2
  - 15 = neutral conductor N
  - 14 = ground conductor

The **power supply** is to be carried out at the terminals:

- 19 = neutral conductor N
- 20 = conductor L
- 12 = ground terminal

The **temperature sensors** (S1 up to S4) are to be connected to the following terminals with either polarity:

- 1 / 2 = Sensor 1 (e.g. Sensor collector 1)
- 3 / 4 = Sensor 2 (e.g. Sensor tank 1)
- 5 / 6 = Sensor 3 (e.g. Sensor tank top)
- 7 / 8 = Sensor 4 (e.g. Sensor return)

All Pt1000 temperature sensors are equipped with a platinum measuring element in their tip. The electrical resistance of the measuring element changes in relation to the temperature (see table in chap. 5).

The difference between **FKP** and **FRP** type sensors only lies in the cable insulation material. The insulation material of FKP type sensor cables resists a higher temperature, so that FKP type sensors should be used as collector sensors. FRP type sensors are best used as reference sensors in tanks or pipes.

The controller is equipped with a **VBus**® for data transfer with and energy supply to external modules. The connection is carried out at the terminals marked "VBus" (either polarity). One or more VBus® modules can be connected via this data bus, such as

- GA3 large display, SD3 smart display
- DL2 datalogger
- VBus®/USB or VBus®/LAN interface adapter
- VBus®/PWM interface adapter
- AM1 alarm module
- WMZ calorimeter module

By means of a DL2 datalogger or an interface adapter, the controller can be connected to a PC or a computer network. With the ServiceCenter Software (RSC) the controller measurements can be read out, processed and visualized. The software allows easy function control of the system. For the remote parametrisation of the controller, a special software tool will be available for download, soon.

### 1.4 Terminal allocation in the different system layouts

#### System layout 1

The controller calculates the temperature difference between collector sensor S1 and tank sensor S2. If the difference is larger than or identical to the adjusted switch-on temperature difference (DT O), the solar pump will be operated by relay 1, and the tank will be loaded until the switch-off temperature difference (DT F) or the maximum tank temperature (S MX) is reached.

Sensors S3 and S4 can optionally be connected for measurement purposes.

If energy metering (OHQM) is activated, sensor S4 has to be connected as return sensor.

If the drainback option (ODB) is activated, relay 2 can be used to operate a booster pump by activating the booster function (OBST).

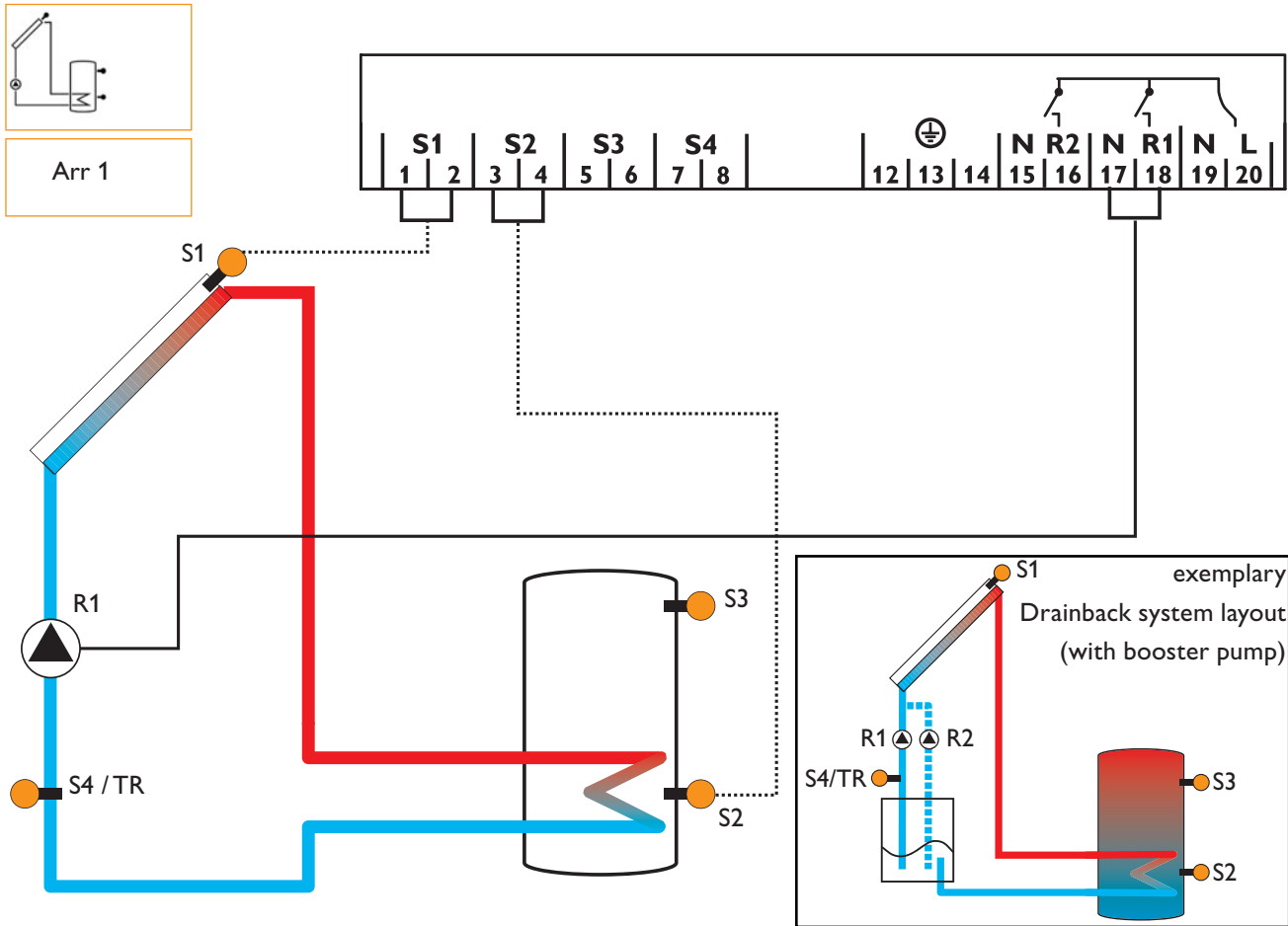

Display Channels				
Channel		Description	Terminal	Page
INIT	x*	ODB initialization active	-	37
FLL	x*	ODB filling time active	-	37
STAB	x*	ODB stabilization in progress	-	37
COL	x	Temperature collector	S1	37
TST	x	Temperature tank	S2	37
S3	x	Temperature sensor 3	S3	37
S4	x	Temperature sensor 4	S4	37
TR	x*	Temperature return sensor	S4	37
n %	x	Pump speed R1	R1	38
hP	x	Operating hours R1	R1	38
hP1	x*	Operating hours R1 (if OBST is activated)	R1	38
hP2	x*	Operating hours R2 (if OBST is activated)	R2	38
kWh	x*	Heat quantity kWh	-	38
MWh	x*	Heat quantity MWh	-	38
TIME	x	Time	-	34

Adjustment Channels				
Channel		Description	Factory setting	Page
Arr	x	System	1	39
DT O	x	Switch-on temperature difference	12.0 °Ra [6.0 K]	39
DT F	x	Switch-off temperature difference	8.0 °Ra [4.0 K]	39
DT S	x	Nominal temperature difference	20.0 °Ra [10.0 K]	39
RIS	x	Rise control R1	4 °Ra [2 K]	39
nMN	x	Minimum pump speed	30 %	39
S MX	x	Maximum tank temperature	140 °F [60 °C]	40
EM	x	Emergency temperature collector	270 °F [130 °C]	40
		Emergency temperature collector if ODB is activated:	200 °F [95 °C]	40
OCC	x	Option collector cooling	OFF	41
CMX	x*	Maximum collector temperature	230 °F [110 °C]	41
OSYC	x	Option system cooling	OFF	41
DTCO	x*	Cooling switch-on temperature difference	40.0 °Ra [20.0 K]	41
DTCF	x*	Cooling switch-off temperature difference	30.0 °Ra [15.0 K]	41
OSTC	x	Option tank cooling	OFF	42
OHOL	x*	Option holiday cooling	OFF	42
THOL	x*	Holiday cooling temperature	110 °F [40 °C]	42
OCN	x	Option minimum limitation	OFF	42
CMN	x*	Minimum collector temperature	50 °F [10 °C]	42
OCF	x	Option antifreeze	OFF	42
CFR	x*	Antifreeze temperature	40.0 °F [4.0 °C]	42
OTC	x	Option tube collector	OFF	44
TCST	x*	OTC starting time	07:00	44
TCEN	x*	OTC ending time	19:00	44
TCRU	x*	OTC runtime	30 s	44
TCIN	x*	OTC standstill interval	30 min	44
OHQM	x	Option energy metering	OFF	44
FMAX	x*	Maximum flow	6.0 l	44
MEDT	x*	Antifreeze type	1	44
MED%	x*	Antifreeze concentration (only if MEDT = propylene or ethylene)	45 %	44
ODB	x	Drainback option	OFF	45
tDTO	x*	ODB switch-on condition - time period	60 s	45
tFLL	x*	ODB filling time	5.0 min	45
tSTB	x*	ODB stabilization time	2.0 min	45
OBST	s*	Option booster function	OFF	45
MAN1	x	Manual operation R1	Auto	46
MAN2	x	Manual operation R2	Auto	46
LANG	x	Language	En	46
UNIT	x	Temperature unit	°C	46
RESE	x	Reset - back to factory defaults		46
W0050100		Version number		

**Legend:**

Symbol	Specification
x	Channel is available
x*	Channel is available if the corresponding option is activated.
s*	System-specific channel, only available if the corresponding option is activated

**System layout 2**

The controller calculates the temperature difference between collector sensor S1 and tank sensor S2. If the difference is larger than or identical to the adjusted switch-on temperature difference (DT O), the solar pump will be operated by relay 1, and the tank will be loaded until the switch-off temperature difference (DT F) or the maximum tank temperature (S MX) is reached.

Heat exchange from tank 1 to tank 2 will be operated by relay 2, if the temperature difference between sensors S3 and S4 is larger than or identical to the adjusted switch-on temperature difference (DT3O), until the adjusted minimum (MN3O) and maximum (MX3O) temperature thresholds of the respective tanks are reached.

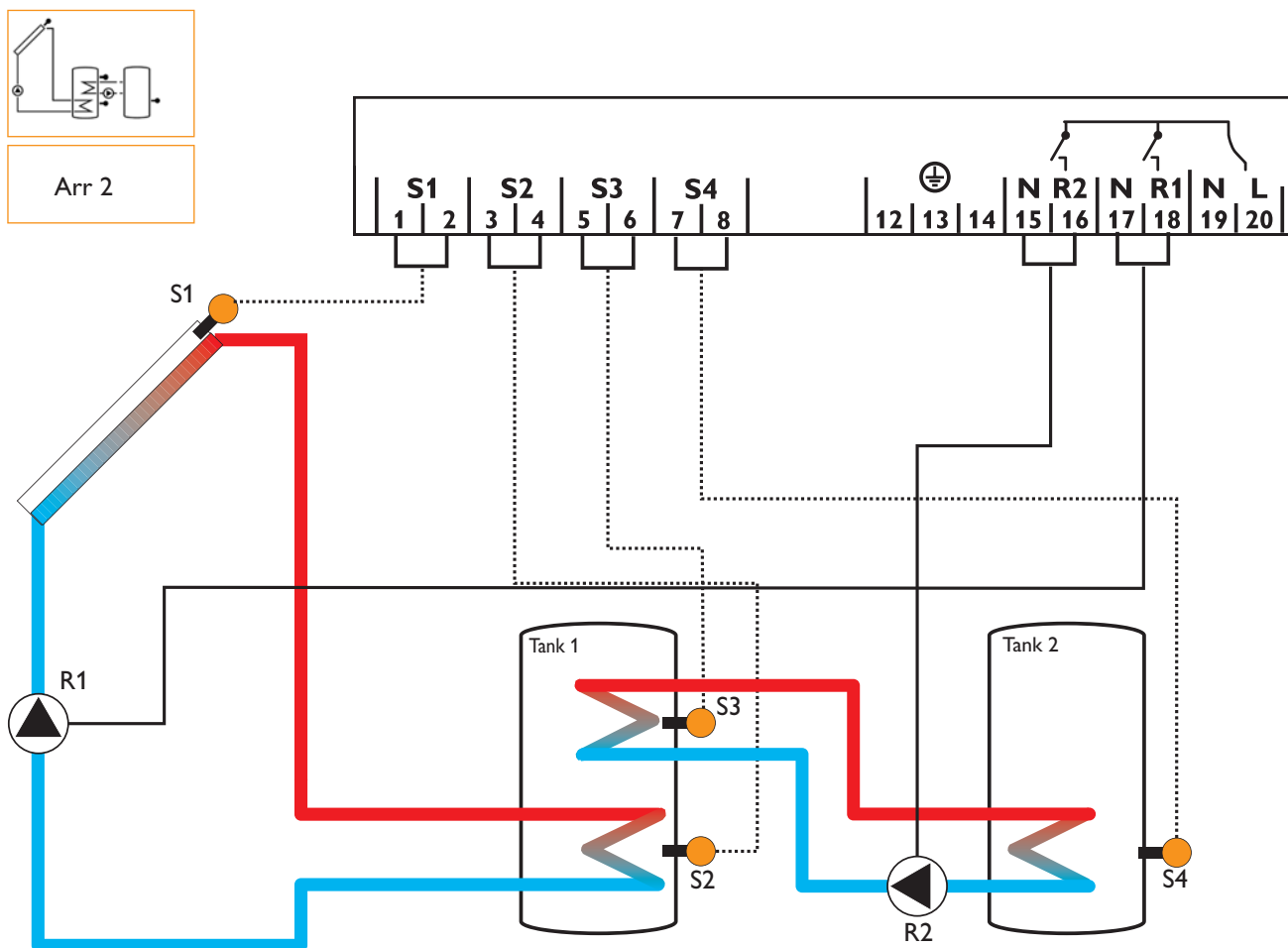

Display Channels				
Channel		Description	Terminal	Page
INIT	x*	ODB initialization active	-	37
FLL	x*	ODB filling time active	-	37
STAB	x*	ODB stabilization in progress	-	37
COL	x	Temperature collector	S1	37
TST1	x	Temperature tank 1 bottom	S2	37
TSTT	x	Temperature tank 1 at the top	S3	37
TST2	x	Temperature tank 2 bottom	S4	37
n1 %	x	Pump speed R1	R1	38
n2 %	x	Pump speed R2	R2	38
h P1	x	Operating hours R1	R1	38
h P2	x	Operating hours R2	R2	38
TIME	x	Time	-	34

Adjustment Channels				
Channel		Description	Factory setting	Page
Arr	x	System	2	39
DT O	x	Switch-on temperature difference	12.0 °Ra [6.0 K]	39
DT F	x	Switch-off temperature difference	8.0 °Ra [4.0 K]	39
DT S	x	Nominal temperature difference	20.0 °Ra [10.0 K]	39
RIS	x	Rise control R1	4 °Ra [2 K]	39
n1MN	x	Minimum pump speed R1	30 %	39
S MX	x	Maximum tank temperature	140 °F [60 °C]	40
n2MN	s	Minimum pump speed R2	30 %	10
EM	x	Emergency temperature collector	270 °F [130 °C]	40
		Emergency temperature collector if ODB is activated:	200 °F [95 °C]	40
OCC	x	Option collector cooling	OFF	41
CMX	x*	Maximum collector temperature	230 °F [110 °C]	41
OSYC	x	Option system cooling	OFF	41
DTCO	x*	Cooling switch-on temperature difference	40.0 °Ra [20.0 K]	41
DTCF	x*	Cooling switch-off temperature difference	30.0 °Ra [15.0 K]	41
OSTC	x	Option tank cooling	OFF	42
OHOL	x*	Option holiday cooling	OFF	42
THOL	x*	Holiday cooling temperature	110 °F [40 °C]	42
OCN	x	Option minimum limitation	OFF	42
CMN	x*	Minimum collector temperature	50 °F [10 °C]	42
OCF	x	Option antifreeze	OFF	42
CFR	x*	Antifreeze temperature	40.0 °F [4.0 °C]	42
OTC	x	Option tube collector	OFF	44
TCST	x*	OTC starting time	07:00	44
TCEN	x*	OTC ending time	19:00	44
TCRU	x*	OTC runtime	30 s	44
TCIN	x*	OTC standstill interval	30 min	44
DT3O	s	Switch-on temperature difference 3	12.0 °Ra [6.0 K]	10
DT3F	s	Switch-off temperature difference 3	8.0 °Ra [4.0 K]	10
DT3S	s	Nominal temperature difference 3	20.0 °Ra [10.0 K]	10
RIS3	s	Rise control R2	4 °Ra [2 K]	10
MX3O	s	Switch-on treshold for maximum temperature	140.0 °F [60.0 °C]	11
MX3F	s	Switch-off treshold for maximum temperature	136.0 °F [58.0 °C]	11
MN3O	s	Switch-on treshold for minimum temperature	40.0 °F [5.0 °C]	11
MN3F	s	Switch-off treshold for minimum temperature	50.0 °F [10.0 °C]	11
ODB	x	Drainback option	OFF	45
tDTO	x*	ODB switch-on condition - time period	60 s	45
tFLL	x*	ODB filling time	5.0 min	45
tSTB	x*	ODB stabilization time	2.0 min	45
MAN1	x	Manual operation R1	Auto	46
MAN2	x	Manual operation R2	Auto	46
LANG	x	Language	En	46
UNIT	x	Temperature unit	°C	46
RESE	x	Reset - back to factory defaults		46
W0050100		Version number		

**Legend:**

Symbol	Specification
x	Channel is available
x*	Channel is available if the corresponding option is activated.
s	Channel is specifically available in this system layout

## System-specific functions

### ΔT control for the heat exchange between 2 tanks

#### DT30:

Switch-on temperature diff.  
Adjustment range: 2.0 ... 40.0 °Ra  
[1.0 ... 20.0 K]  
in steps of 1 °Ra [0.5 K]  
Factory setting: 12.0 °Ra  
[6.0 K]

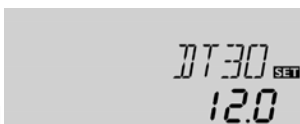

#### DT3F:

Switch-off temperature diff.  
Adjustment range: 1.0 ... 39.0 °Ra  
[0.5 ... 19.5 K]  
in steps of 1 °Ra [0.5 K]  
Factory setting: 8.0 °Ra  
[4.0 K]



### Pump speed control

#### DT3S:

Nominal temperature difference  
Adjustment range: 3.0 ... 60.0 °Ra  
[1.5 ... 30.0 K]  
in steps of 1 °Ra [0.5 K]  
Factory setting: 20.0 °Ra  
[10.0 K]

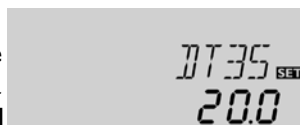

#### RIS3:

Rise  
Adjustment range:  
2 ... 40 °Ra [1 ... 20 K]  
in steps of 2 °Ra [1 K]  
Factory setting: 4 °Ra [2 K]



### Minimum pump speed

#### n2MN:

Pump speed control  
Adjustment range:  
30 ... 100  
in steps of 5 %  
Factory setting: 30

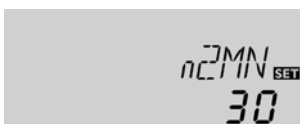

The following adjustments are used for the specific function in system layout 2.

#### Reference sensors for this function are S3 and S4.

In system layout 2 the controller is equipped with an additional differential control for heat exchange between two tanks. The basic differential function is adjusted using the switch-on (**DT30**) and switch-off (**DT3F**) temperature differences.

When the temperature difference exceeds the switch-on temperature difference, relay 2 switches on. If the temperature difference then falls below the adjusted switch-off temperature difference, relay 2 switches off.



#### Note:

The switch-on temperature difference must be at least 1 °Ra [0.5 K] higher than the switch-off temperature difference.



#### Note:

For pump speed control of the heat exchange pump, the operation mode of relay 2 (**MAN2**) must be set to Auto.

When the switch-on temperature difference is reached, the pump is activated at full speed for 10 seconds. Then, the speed is reduced to the minimum pump speed value (**n2MN**). If the temperature difference reaches the adjusted nominal temperature difference (**DT3S**), the pump speed increases by one step (10 %). If the difference increases by the adjustable rise value, the pump speed increases by 10 % respectively until the maximum pump speed of 100 % is reached. The response of the controller can be adapted via the parameter **RIS3**.



#### Note:

The nominal temperature difference must be at least 1 °Ra [0.5 K] higher than the switch-on temperature difference.

A relative minimum pump speed can be allocated to the output R2 via the adjustment channel **n2MN**.



#### Note:

When loads which are not speed-controlled (e.g. valves) are used, the value must be set to 100 % in order to deactivate pump speed control.

### Maximum temperature limitation

#### MX30 / MX3F:

Maximum temperature limitation  
Adjustment range:  
30.0...200.0 °F  
[0.0 ... 95.0 °C]  
in steps of 1 °Ra [0.5 K]  
Factory setting:  
MX3O: 140.0 °F [60.0 °C]  
MX3F: 136.0 °F [58.0 °C]



### Minimum temperature limitation

#### MN30 / MN3F:

Minimum temperature limitation  
Adjustment range:  
30.0...190.0 °F  
[0.0 ... 90.0 °C]  
in steps of 1 °Ra [0.5 K]  
Factory setting (Arr = 2 only):  
MN3O: 40.0 °F [5.0 °C]  
MN3F: 50.0 °F [10.0 °C]



Minimum and maximum temperature limits can be set for the heat exchange function.

The maximum temperature limitation uses sensor 4 as reference sensor.

The maximum temperature limitation function provides a maximum temperature setting, usually to reduce scald risk in a storage tank. If **MX3O** is exceeded, relay 2 is switched off until the temperature at sensor 4 falls below **MX3F**.

The minimum temperature limitation uses sensor 3 as reference sensor.

The minimum temperature limitation function provides a minimum temperature setting for the heat source in system layout 2. If the temperature at sensor 3 falls below **MN3O**, relay 2 is switched off until the temperature at sensor 3 exceeds **MN3F**.

Both switch-on and switch-off temperature differences **DT3O** and **DT3F** are valid for the maximum and minimum temperature limitation.

**System layout 3**

The controller calculates the temperature difference between collector sensor S1 and tank sensor S2. If the difference is larger than or identical to the adjusted switch-on temperature difference (DT O), the solar pump will be operated by relay 1, and the tank will be loaded until the switch-off temperature difference (DT F) or the maximum tank temperature (S MX) is reached.

Sensor S3 is used for a thermostatic function, which operates relay 2 for backup heating or heat dump purposes, when the adjusted thermostat switch-on temperature (AH O) is reached. This function can optionally be combined with up to three adjustable time frames.

Sensor S3 can also be optionally used as a reference sensor for the thermal disinfection function OTD.

Sensor S4 can optionally be connected for measurement purposes. If energy metering (OHQM) is activated, sensor S4 has to be connected as return sensor.

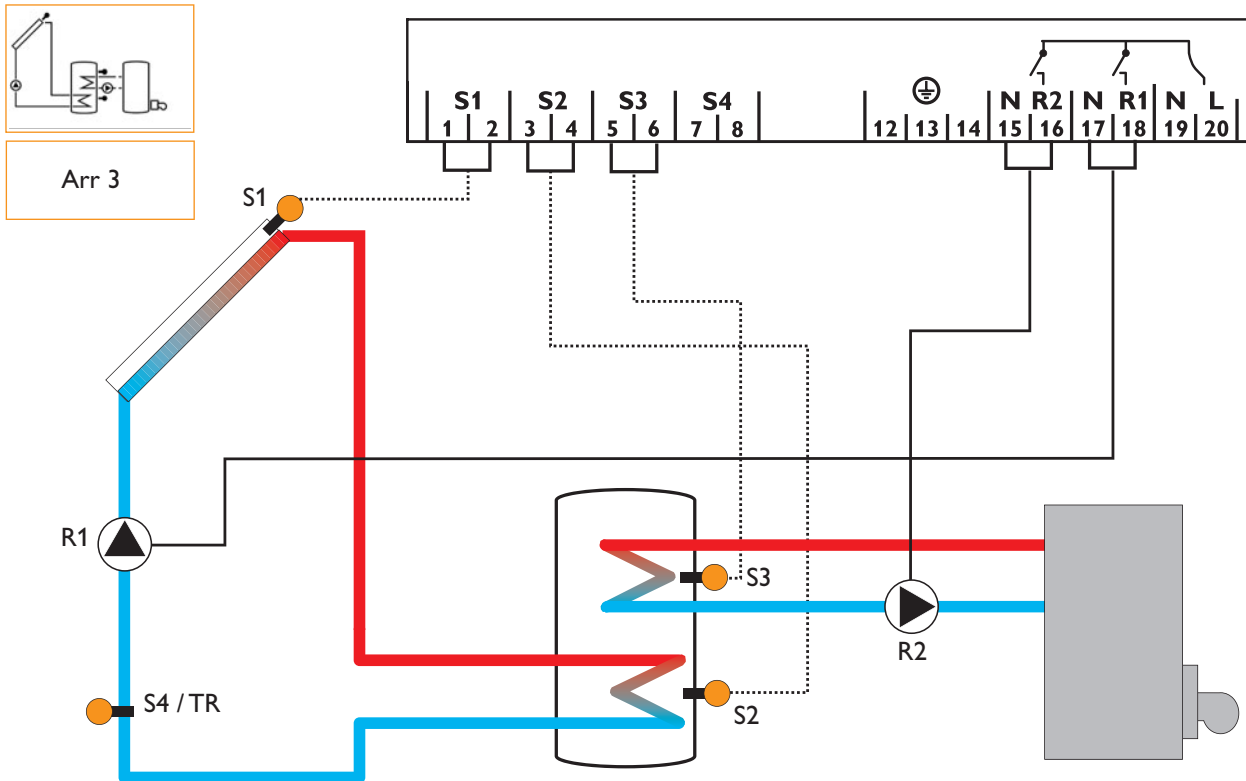

Display Channels				
Channel		Description	Terminal	Page
INIT	x*	ODB initialization active	-	37
FLL	x*	ODB filling time active	-	37
STAB	x*	ODB stabilization in progress	-	37
COL	x	Temperature collector	S1	37
TSTB	x	Temperature tank 1 bottom	S2	37
TSTT	x	Temperature tank 1 at the top	S3	37
TDIS	x*	Thermal disinfection temperature	S3	37
S4	x	Temperature sensor 4	S4	37
TR	x*	Temperature return sensor	S4	37
n1 %	x	Pump speed R1	R1	38
h P1	x	Operating hours R1	R1	38
h P2	x	Operating hours R2	R2	38
kWh	x*	Heat quantity kWh	-	38
MWh	x*	Heat quantity MWh	-	38
CDIS	x*	Countdown of monitoring period	-	38
SDIS	x*	Starting time display	-	38
DDIS	x*	Heating period display	-	38
TIME	x	Time	-	34

Adjustment Channels				
Channel		Description	Factory setting	Page
Arr	x	System	3	39
DT O	x	Switch-on temperature difference	12.0 °Ra [6.0 K]	39
DT F	x	Switch-off temperature difference	8.0 °Ra [4.0 K]	39
DT S	x	Nominal temperature difference	20.0 °Ra [10.0 K]	39
RIS	x	Rise control R1	4 °Ra [2 K]	39
n1MN	x	Minimum pump speed R1	30 %	39
S MX	x	Maximum tank temperature	140 °F [60 °C]	40
EM	x	Emergency temperature collector	270 °F [130 °C]	40
		Emergency temperature collector if ODB is activated:	200 °F [95 °C]	40
OCC	x	Option collector cooling	OFF	41
CMX	x*	Maximum collector temperature	230 °F [110 °C]	41
OSYC	x	Option system cooling	OFF	41
DTCO	x*	Cooling switch-on temperature difference	40.0 °Ra [20.0 K]	41
DTCF	x*	Cooling switch-off temperature difference	30.0 °Ra [15.0 K]	41
OSTC	x	Option tank cooling	OFF	42
OHOL	x*	Option holiday cooling	OFF	42
THOL	x*	Holiday cooling temperature	110 °F [40 °C]	42
OCN	x	Option minimum limitation	OFF	42
CMN	x*	Minimum collector temperature	50 °F [10 °C]	42
OCF	x	Option antifreeze	OFF	42
CFR	x*	Antifreeze temperature	40.0 °F [4.0 °C]	42
OTC	x	Option tube collector	OFF	44
TCST	x*	OTC starting time	07:00	44
TCEN	x*	OTC ending time	19:00	44
TCRU	x*	OTC runtime	30 s	44
TCIN	x*	OTC standstill interval	30 min	44
OHQM	x	Option energy metering	OFF	44
FMAX	x*	Maximum flow	6.0 l	44
MEDT	x*	Antifreeze type	1	44
MED%	x*	Antifreeze concentration	45 %	44
AH O	s	Switch-on temp. for thermostat 1	110 °F [40 °C]	14
AH F	s	Switch-off temp. for thermostat 1	120 °F [45 °C]	14
t1 O	s	Switch-on time 1 thermostat	00:00	14
t1 F	s	Switch-off time 1 thermostat	00:00	14
t2 O	s	Switch-on time 2 thermostat	00:00	14
t2 F	s	Switch-off time 2 thermostat	00:00	14
t3 O	s	Switch-on time 3 thermostat	00:00	14
t3 F	s	Switch-off time 3 thermostat	00:00	14
ODB	x	Drainback option	OFF	45
tDTO	x*	ODB switch-on condition - time period	60 s	45
tFLL	x*	ODB filling time	5.0 min	45
tSTB	x*	ODB stabilization time	2.0 min	45
OTD	s	Option thermal disinfection	OFF	15
PDIS	s*	Monitoring period	01:00	15
DDIS	s*	Heating period	01:00	15
TDIS	s*	Disinfection temperature	140 °F [60 °C]	15
SDIS	s*	Starting time	00:00	15
MAN1	x	Manual operation R1	Auto	46
MAN2	x	Manual operation R2	Auto	46
LANG	x	Language	En	46
UNIT	x	Temperature unit	°C	46
RESE	x	Reset - back to factory defaults		46
W0050100		Version number		

**Legend:**

Symbol	Specification
x	Channel is available
x*	Channel is available if the corresponding option is activated.
s	Channel is specifically available in this system layout
s*	System-specific channel, only available if the corresponding option is activated

**System-specific functions**

The following functions are exclusively available in system layout 3. The corresponding channels will not be available in any other system layout.

**Thermostat function**

Backup heating

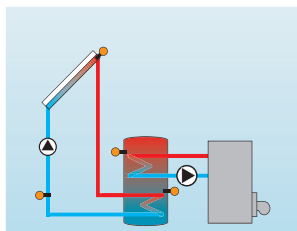

The thermostat function works independently from the solar operation and can be used for using surplus energy or for backup heating.

- **AH O < AH F**  
thermostat function for backup heating
- **AH O > AH F**  
thermostat function for using surplus energy

Use of surplus energy

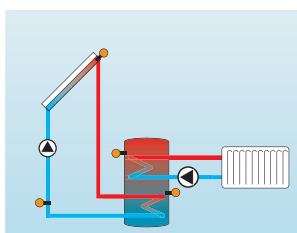

The symbol  will be shown on the display if the second relay output is activated.

**Reference sensor for the thermostat function is S3!**

**AH O:**

Thermostat switch-on temp.  
Adjustment range:  
30.0... 200.0 °F  
[0.0 ... 95.0 °C]  
in steps of 1.0 °Ra [0.5 K]  
Factory setting:  
110.0°F [40.0 °C]



**AH F:**

Thermostat switch-off temp.  
Adjustment range:  
30.0... 200.0 °F  
[0.0 ... 95.0 °C]  
in steps of 1.0 °Ra [0.5 K]  
Factory setting:  
120.0 °F [45.0 °C]

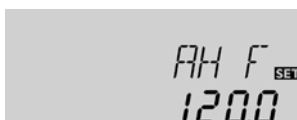

**t1 O, t2 O, t3 O:**

Thermostat switch-on time  
Adjustment range:  
00:00...23:45  
Factory setting: 00:00



In order to block the thermostat function for a certain period, there are three time frames t1 ... t3. If the function should be active between 6:00 and 9:00, set **t1 O** to 6:00 and **t1 F** to 9:00.

If all time frames are set to 00:00 o'clock, the thermostat function is continuously activated (factory setting).

**t1 F, t2 F, t3 F:**

Thermostat switch-off time  
Adjustment range:  
00:00...23:45  
Factory setting: 00:00

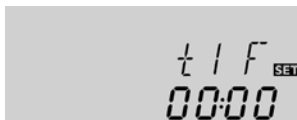

**Option: Thermal disinfection of the upper DHW zone (OTD)**

**OTD:**

Thermal disinfection function  
Adjustment range: ON / OFF  
Factory setting: OFF



**PDIS:**

Monitoring period  
Adjustment range:  
0 ... 30:0 ... 24 h (dd:hh)  
Factory setting: 01:00



**DDIS**

Heating period  
Adjustment range:  
00:00 ... 23:59 (hh:mm)  
Factory setting: 01:00



**TDIS**

Disinfection temperature  
Adjustment range:  
30 ... 200 °F  
[0 ... 95 °C]  
in steps of 2 °F [2 °C]  
Factory setting:  
140 °F [60 °C]

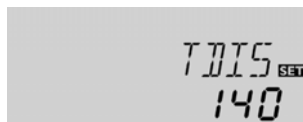

This function is used for protecting the upper tank zone against Legionella by activating the backup heating.

**Reference sensor for the thermal disinfection is S3!**

➔ To activate the function, select “On” in the **OTD** channel.

For thermal disinfection, the temperature in the upper DHW tank zone has to be monitored. This protection is ensured when, during the monitoring period (**PDIS**), the disinfection temperature (**TDIS**) is continuously exceeded for the entire heating period (**DDIS**). S3 is used as the reference sensor and displayed as **TSTT**.

If **OTD** is activated, **PDIS** will start as soon as the temperature at S3 falls below **TDIS**. The display channel **CDIS** appears, counting backwards the remaining time of **PDIS**. If, during the monitoring period, the temperature at S3 exceeds **TDIS** continuously for the duration of **DDIS**, thermal disinfection is considered complete and a new monitoring period begins.

If **CDIS** counts down to 00:00, relay 2 will be operated in order to use the backup heating for thermal disinfection. **CDIS** will then be replaced with a display channel **DDIS** showing the adjusted heating period. **DDIS** will start counting down the heating period as soon as **TDIS** is exceeded at S3. As long as **DDIS** is active, the temperature at S3 will be displayed as **TDIS** instead of **TSTT**.

If, during **DDIS**, the temperature at S3 exceeds **TDIS** by more than 10 °Ra [5 K], relay 2 is switched off until the temperature falls below **TDIS** + 4 °Ra [2 K].

If, during **DDIS**, the temperature at S3 falls below **TDIS**, the heating period will restart. **DDIS** can only be completed when **TDIS** is exceeded without interruption.

Due to the flexible control logic, the exact time of thermal disinfection is not predictable. In order to set a fixed time for the disinfection to be run, the starting delay **SDIS** must be employed:

When a starting time for thermal disinfection with starting delay is adjusted in **SDIS**, the thermal disinfection will be delayed until that time, even after the **CDIS** has counted down to 00:00. If **CDIS** ends, for example, at 12:00 o'clock, and **SDIS** has been set to 18:30, relay 2 will be operated with a delay of 6.5 hours at 18:30 instead of 12:00.

During the waiting time, **SDIS** is displayed with the adjusted starting time (flashing).

If, during the waiting time, the temperature at S3 exceeds **TDIS** for the adjusted heating period **DDIS**, thermal disinfection is considered complete and a new monitoring period begins.

If the starting time is adjusted to 00:00 (factory setting), the delay function is inactive.

Upon delivery, **OTD** is deactivated. The adjustment values **PDIS**, **TDIS**, **DDIS** and **SDIS** are displayed after the option has been activated. After the thermal disinfection function has been completed, the values will be “hidden” and the monitoring period will be displayed.

**Thermal disinfection with starting delay**

**SDIS**

Starting time  
Adjustment range:  
00:00 ... 24:00 (o'clock)  
Factory setting: 00:00

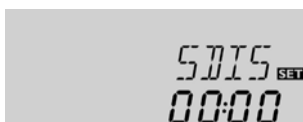

**System layout 4**

The controller calculates the temperature differences between collector sensor S1 and tank sensors S2 and S3. If the differences are larger than or identical to the adjusted switch-on temperature differences (DT1O / DT2O), the solar pump will be operated by relay 1, and the respective tank zone will be loaded until the switch-off temperature differences (DT1F / DT2F) or the maximum tank tempera-

tures (S1MX / S2MX) are reached. The priority logic causes priority loading of the upper zone of the tank, if possible. The 3-way-valve will be operated by relay 2 then.

Sensor S4 can optionally be connected for measurement purposes.

If energy metering (OHQM) is activated, sensor S4 has to be connected as return sensor.

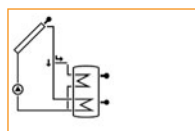

Arr 4

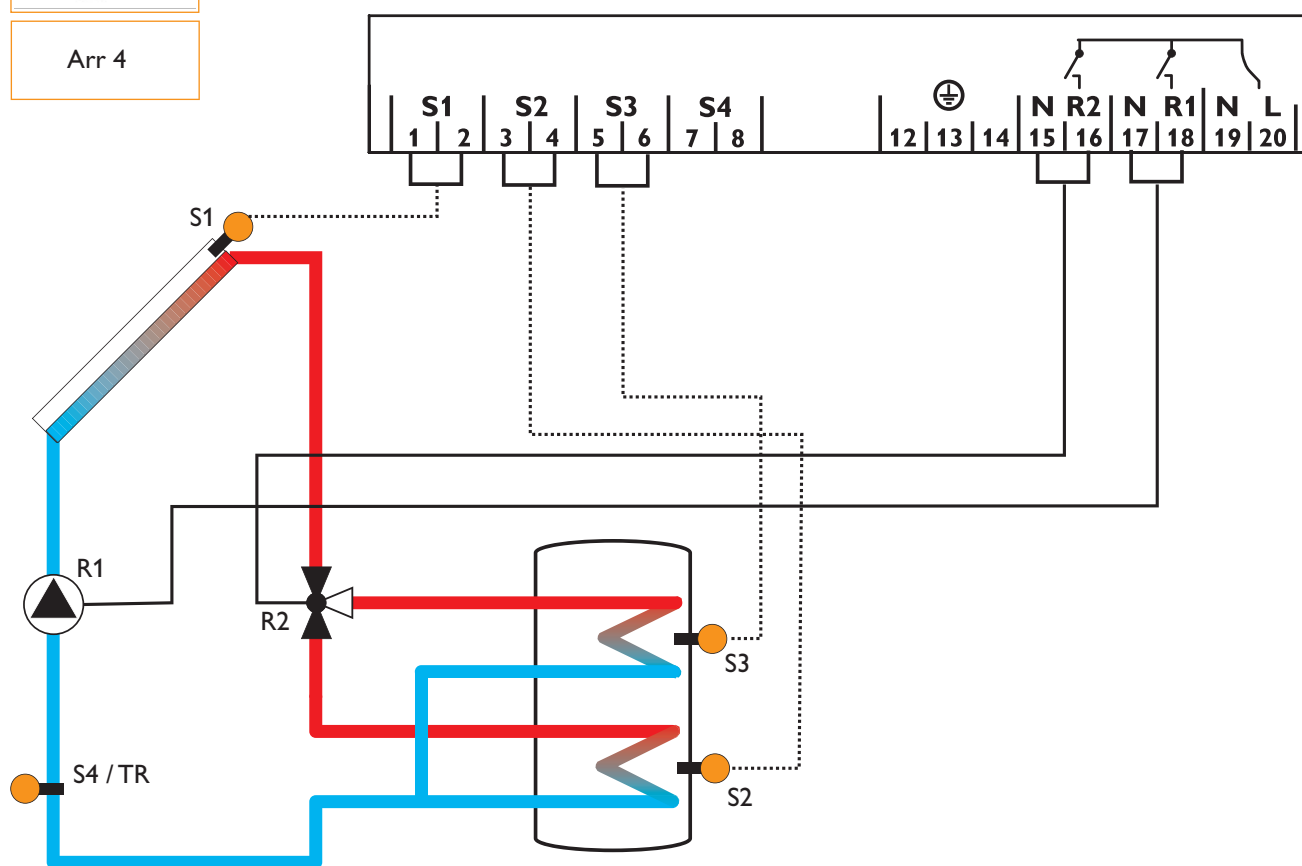

Display Channels				
Channel		Description	Terminal	Page
COL	x	Temperature collector	S1	37
TSTB	x	Temperature tank 1 bottom	S2	37
TSTT	x	Temperature tank 1 at the top	S3	37
S4	x	Temperature sensor 4	S4	37
TR	x*	Temperature return sensor	S4	37
n %	x	Pump speed relay	R1	38
hP1	x	Operating hours R1	R1	38
hP2	x	Operating hours R2	R2	38
kWh	x*	Heat quantity kWh	-	38
MWh	x*	Heat quantity MWh	-	38
TIME	x	Time	-	34

Adjustment Channels				
Channel		Description	Factory setting	Page
Arr	x	System	4	39
nMN	x	Minimum pump speed	30 %	39
DT1O	x	Switch-on temperature difference 1	12.0 °Ra [6.0 K]	39
DT1F	x	Switch-off temperature difference 1	8.0 °Ra [4.0 K]	39
DT1S	x	Nominal temperature difference 1	20.0 °Ra [10.0 K]	39
RIS1	x	Rise control R1	4 °Ra [2 K]	39
S1 MX	x	Maximum temperature tank 1	140 °F [60 °C]	40
DT2O	x	Switch-on temperature difference 2	12.0 °Ra [6.0 K]	39
DT2F	x	Switch-off temperature difference 2	8.0 °Ra [4.0 K]	39
DT2S	x	Nominal temperature difference 2	20.0 °Ra [10.0 K]	39
RIS2	x	Rise control R2	4 °Ra [2 K]	39
S2MX	x	Maximum temperature tank 2	140 °F [60 °C]	40
EM	x	Emergency temperature collector	270 °F [130 °C]	40
OCC	x	Option collector cooling	OFF	41
CMX	x*	Maximum collector temperature	230 °F [110 °C]	41
OSYC	x	Option system cooling	OFF	41
DTCO	x*	Cooling switch-on temperature difference	40.0 °Ra [20.0 K]	41
DTCF	x*	Cooling switch-off temperature difference	30.0 °Ra [15.0 K]	41
OSTC	x	Option tank cooling	OFF	42
OHOL	x*	Option holiday cooling	OFF	42
THOL	x*	Holiday cooling temperature	110 °F [40 °C]	42
OCN	x	Option minimum limitation	OFF	42
CMN	x*	Minimum collector temperature	50 °F [10 °C]	42
OCF	x	Option antifreeze	OFF	42
CFR	x*	Antifreeze temperature	40.0 °F [4.0 °C]	42
PRIO	x	Priority	2	43
tLB	x	Break time	2 min	43
tRUN	x	Circulation runtime	15 min	43
OTC	x	Option tube collector	OFF	44
TCST	x*	OTC starting time	07:00	44
TCEN	x*	OTC ending time	19:00	44
TCRU	x*	OTC runtime	30 s	44
TCIN	x*	OTC standstill interval	30 min	44
OHQM	x	Option energy metering	OFF	44
FMAX	x*	Maximum flow	6.0 l	44
MEDT	x*	Antifreeze type	1	44
MED%	x*	Antifreeze concentration (only if MEDT = propylene or ethylene)	45 %	44
MAN1	x	Manual operation R1	Auto	46
MAN2	x	Manual operation R2	Auto	46
LANG	x	Language	En	46
UNIT	x	Temperature unit	°C	46
RESE	x	Reset - back to factory defaults		46
W0050100		Version number		

## Legend:

Symbol	Specification
x	Channel is available
x*	Channel is available if the corresponding option is activated.

**System layout 5**

The controller calculates the temperature differences between collector sensor S1 and tank sensors S2 and S3. If the differences are larger than or identical to the adjusted switch-on temperature differences (DT1O / DT2O), the solar pump will be operated by relay 1, and the respective tank will be loaded until the switch-off temperature differences (DT1F / DT2F) or the maximum tank temperatures (S1MX /

S2MX) are reached. The priority logic causes priority loading of tank 1, if possible. For loading tank 2 the 3-way-valve will be operated by relay 2.

Sensor S4 can optionally be connected for measurement purposes.

If energy metering (OHQM) is activated, sensor S4 has to be connected as return sensor.

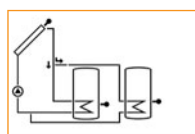

Arr 5

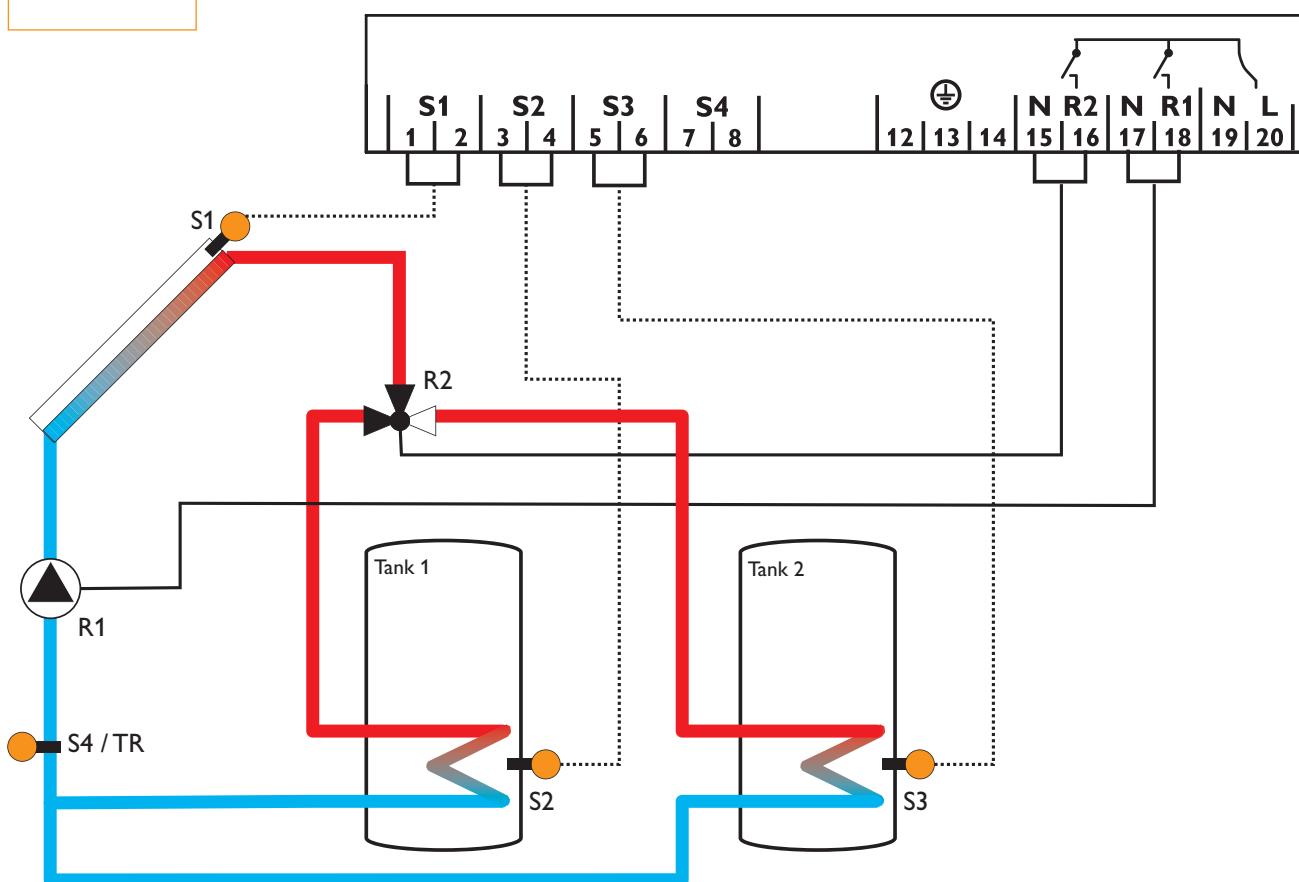

Display Channels				
Channel		Description	Terminal	Page
COL	x	Temperature collector	S1	37
TST1	x	Temperature tank 1 bottom	S2	37
TST2	x	Temperature tank 2 bottom	S3	37
S4	x	Temperature sensor 4	S4	37
TR	x*	Temperature return sensor	S4	37
n %	x	Pump speed relay	R1	38
hP1	x	Operating hours R1	R1	38
hP2	x	Operating hours R2	R2	38
kWh	x*	Heat quantity kWh	-	38
MWh	x*	Heat quantity MWh	-	38
TIME	x	Time	-	34

Adjustment Channels				
Channel		Description	Factory setting	Page
Arr	x	System	5	39
nMN	x	Minimum pump speed	30 %	39
DT1O	x	Switch-on temperature difference 1	12.0 °Ra [6.0 K]	39
DT1F	x	Switch-off temperature difference 1	8.0 °Ra [4.0 K]	39
DT1S	x	Nominal temperature difference 1	20.0 °Ra [10.0 K]	39
RIS1	x	Rise control R1	4 °Ra [2 K]	39
S1 MX	x	Maximum temperature tank 1	140 °F [60 °C]	40
DT2O	x	Switch-on temperature difference 2	12.0 °Ra [6.0 K]	39
DT2F	x	Switch-off temperature difference 2	8.0 °Ra [4.0 K]	39
DT2S	x	Nominal temperature difference 2	20.0 °Ra [10.0 K]	39
RIS2	x	Rise control R2	4 °Ra [2 K]	39
S2MX	x	Maximum temperature tank 2	140 °F [60 °C]	40
EM	x	Emergency temperature collector	270 °F [130 °C]	40
OCC	x	Option collector cooling	OFF	41
CMX	x*	Maximum collector temperature	230 °F [110 °C]	41
OSYC	x	Option system cooling	OFF	41
DTCO	x*	Cooling switch-on temperature difference	40.0 °Ra [20.0 K]	41
DTCF	x*	Cooling switch-off temperature difference	30.0 °Ra [15.0 K]	41
OSTC	x	Option tank cooling	OFF	42
OHOL	x*	Option holiday cooling	OFF	42
THOL	x*	Holiday cooling temperature	110 °F [40 °C]	42
OCN	x	Option minimum limitation	OFF	42
CMN	x*	Minimum collector temperature	50 °F [10 °C]	42
OCF	x	Option antifreeze	OFF	42
CFR	x*	Antifreeze temperature	40.0 °F [4.0 °C]	42
PRIO	x	Priority	1	43
tLB	x	Break time	2 min	43
tRUN	x	Circulation runtime	15 min	43
OTC	x	Option tube collector	OFF	44
TCST	x*	OTC starting time	07:00	44
TCEN	x*	OTC ending time	19:00	44
TCRU	x*	OTC runtime	30 s	44
TCIN	x*	OTC standstill interval	30 min	44
OHQM	x	Option energy metering	OFF	44
FMAX	x*	Maximum flow	6.0 l	44
MEDT	x*	Antifreeze type	1	44
MED%	x*	Antifreeze concentration (only if MEDT = propylene or ethylene)	45 %	44
MAN1	x	Manual operation R1	Auto	46
MAN2	x	Manual operation R2	Auto	46
LANG	x	Language	En	46
UNIT	x	Temperature unit	°C	46
RESE	x	Reset - back to factory defaults		46
W0050100		Version number		

**Legend:**

Symbol	Specification
x	Channel is available
x*	Channel is available if the corresponding option is activated.

**System layout 6**

The controller calculates the temperature differences between collector sensor S1 and tank sensors S2 and S3. If the differences are larger than or identical to the adjusted switch-on temperature differences (DT1O / DT2O), the solar pumps will be operated by relay 1 and / or relay 2, and the respective tank will be loaded until the switch-off temperature differences (DT1F / DT2F) or the maximum

tank temperatures (S1MX / S2MX) are reached. The priority logic causes priority loading of the selected tank (PRIO), if possible. Loading both tanks simultaneously is possible as well (PRIO = 0).

Sensor S4 can optionally be connected for measurement purposes.

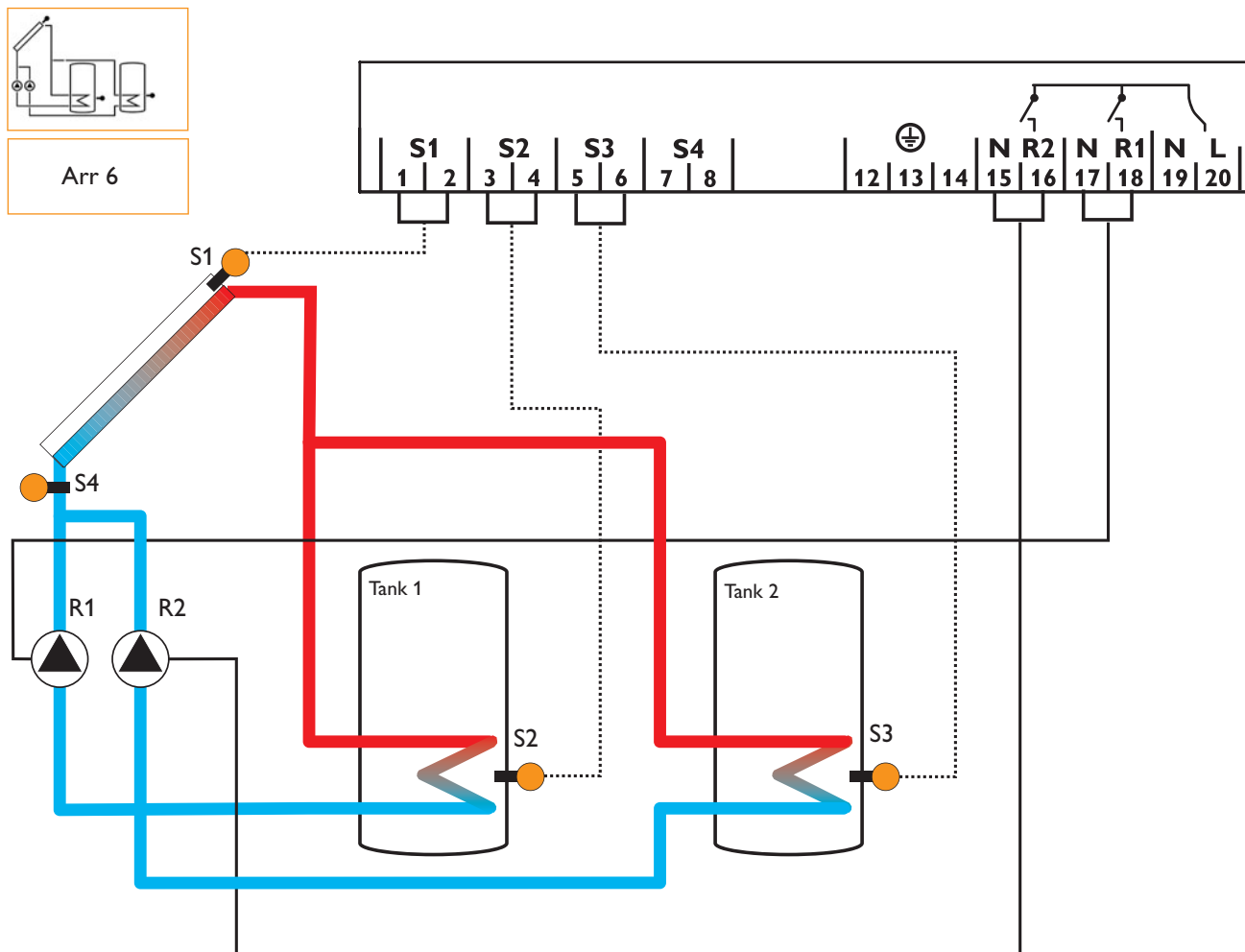

Display Channels				
Channel		Description	Terminal	Page
COL	x	Temperature collector	S1	37
TST1	x	Temperature tank 1 bottom	S2	37
TST2	x	Temperature tank 2 bottom	S3	37
S4	x	Temperature sensor 4	S4	37
n1 %	x	Pump speed R1	R1	38
n2 %	x	Pump speed R2	R2	38
h P1	x	Operating hours R1	R1	38
h P2	x	Operating hours R2	R2	38
TIME	x	Time	-	34

Adjustment Channels				
Channel		Description	Factory setting	Page
Arr	x	System	6	39
DT1O	x	Switch-on temperature difference 1	12.0 °Ra [6.0 K]	39
DT1F	x	Switch-off temperature difference 1	8.0 °Ra [4.0 K]	39
DT1S	x	Nominal temperature difference 1	20.0 °Ra [10.0 K]	39
RIS1	x	Rise control R1	4 °Ra [2 K]	39
n1MN	x	Minimum pump speed R1	30 %	39
S1 MX	x	Maximum temperature tank 1	140 °F [60 °C]	40
DT2O	x	Switch-on temperature difference 2	12.0 °Ra [6.0 K]	39
DT2F	x	Switch-off temperature difference 2	8.0 °Ra [4.0 K]	39
DT2S	x	Nominal temperature difference 2	20.0 °Ra [10.0 K]	39
RIS2	x	Rise control R2	4 °Ra [2 K]	39
n2MN	x	Minimum pump speed R2	30 %	39
S2MX	x	Maximum temperature tank 2	140 °F [60 °C]	40
EM	x	Emergency temperature collector	270 °F [130 °C]	40
OCC	x	Option collector cooling	OFF	41
CMX	x*	Maximum collector temperature	230 °F [110 °C]	41
OSYC	x	Option system cooling	OFF	41
DTCO	x*	Cooling switch-on temperature difference	40.0 °Ra [20.0 K]	41
DTCF	x*	Cooling switch-off temperature difference	30.0 °Ra [15.0 K]	41
OSTC	x	Option tank cooling	OFF	42
OHOL	x*	Option holiday cooling	OFF	42
THOL	x*	Holiday cooling temperature	110 °F [40 °C]	42
OCN	x	Option minimum limitation	OFF	42
CMN	x*	Minimum collector temperature	50 °F [10 °C]	42
OCF	x	Option antifreeze	OFF	42
CFR	x*	Antifreeze temperature	40.0 °F [4.0 °C]	42
PRIO	x	Priority	1	43
tLB	x	Break time	2 min	43
tRUN	x	Circulation runtime	15 min	43
DTSE	x*	Spread temperature difference	70 °Ra [40 K]	43
OTC	x	Option tube collector	OFF	44
TCST	x*	OTC starting time	07:00	44
TCEN	x*	OTC ending time	19:00	44
TCRU	x*	OTC runtime	30 s	44
TCIN	x*	OTC standstill interval	30 min	44
MAN1	x	Manual operation R1	Auto	46
MAN2	x	Manual operation R2	Auto	46
LANG	x	Language	En	46
UNIT	x	Temperature unit	°C	46
RESE	x	Reset - back to factory defaults		46
W0050100		Version number		

**Legend:**

Symbol	Specification
x	Channel is available
x*	Channel is available if the corresponding option is activated.

**System layout 7**

The controller calculates the temperature differences between the collector sensors S1 and S3 and the tank sensor S2. If the differences are larger than or identical to the adjusted switch-on temperature difference (DT O), the respective solar pump will be operated by relay 1 and / or

relay 2, and the tank will be loaded until the switch-off temperature difference (DT F) or the maximum tank temperature (S MX) is reached.

Sensor S4 can optionally be connected for measurement purposes.

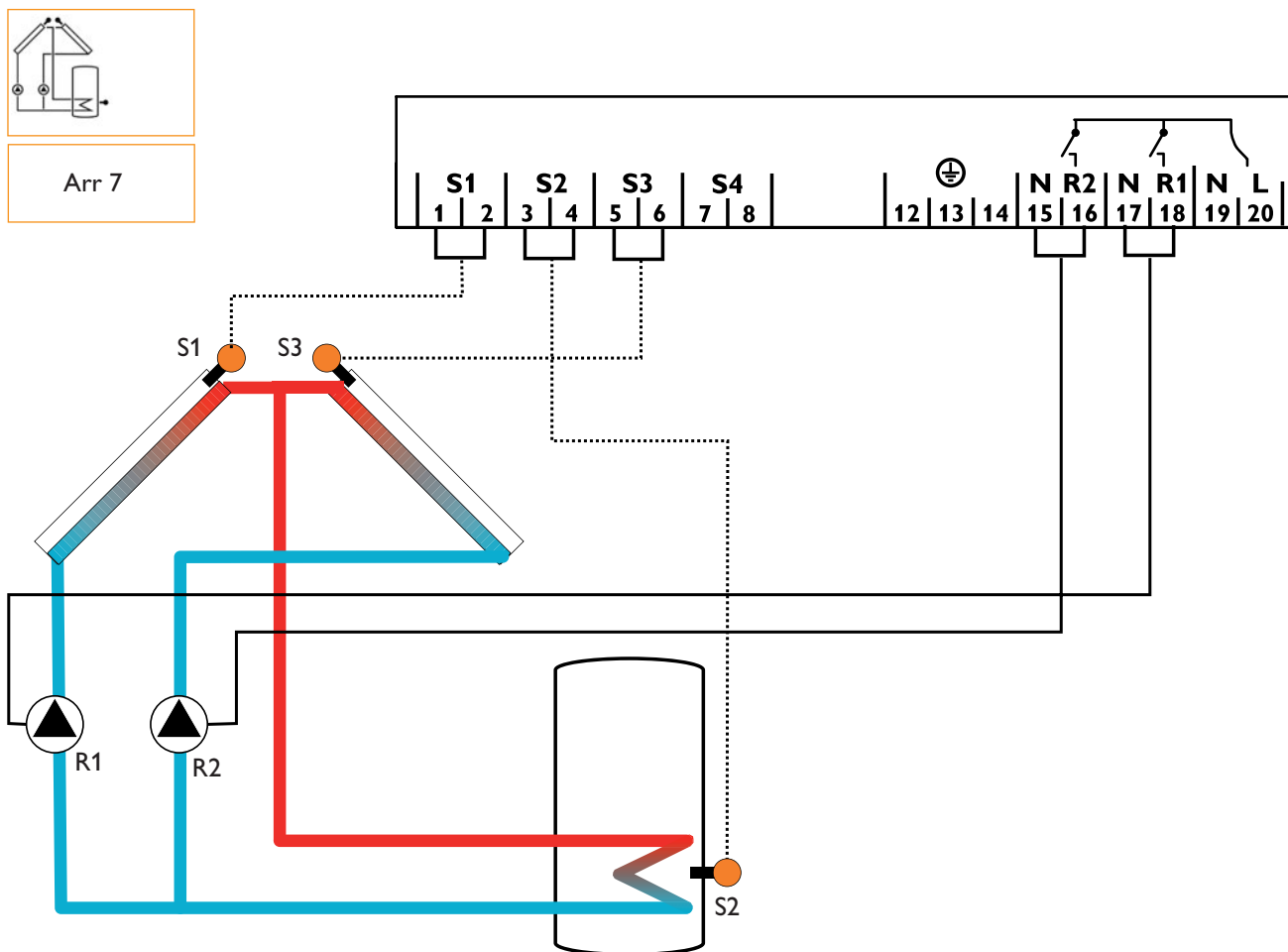

Display Channels				
Channel		Description	Terminal	Page
COL1	x	Temperature collector 1	S1	37
TST	x	Temperature tank	S2	37
COL2	x	Temperature collector 2	S3	37
S4	x	Temperature sensor 4	S4	37
n1 %	x	Pump speed R1	R1	38
n2 %	x	Pump speed R2	R2	38
h P1	x	Operating hours R1	R1	38
h P2	x	Operating hours R2	R2	38
TIME	x	Time	-	34

Adjustment Channels				
Channel		Description	Factory setting	Page
Arr	x	System	7	39
DT O	x	Switch-on temperature difference	12.0 °Ra [6.0 K]	39
DT F	x	Switch-off temperature difference	8.0 °Ra [4.0 K]	39
DT S	x	Nominal temperature difference	20.0 °Ra [10.0 K]	39
RIS	x	Rise control R1 / R2	4 °Ra [2 K]	39
n1MN	x	Minimum pump speed R1	30 %	39
S MX	x	Maximum tank temperature	140 °F [60 °C]	40
n2MN	x	Minimum pump speed R2	30 %	39
EM1	x	Emergency temperature collector	270 °F [130 °C]	40
EM2	x	Emergency temperature collector	270 °F [130 °C]	40
OCC1	x	Option collector cooling collector 1	OFF	41
CMX1	x*	Maximum temperature collector 1	230 °F [110 °C]	41
OCC2	x	Option collector cooling collector 2	OFF	41
CMX2	x*	Maximum temperature collector 2	230 °F [110 °C]	41
OSYC	x	Option system cooling	OFF	41
DTCO	x*	Cooling switch-on temperature difference	40.0 °Ra [20.0 K]	41
DTCF	x*	Cooling switch-off temperature difference	30.0 °Ra [15.0 K]	41
OSTC	x	Option tank cooling	OFF	42
OHOL	x*	Option holiday cooling	OFF	42
THOL	x*	Holiday cooling temperature	110 °F [40 °C]	42
OCN1	x	Option minimum limitation collector 1	OFF	42
CMN1	x*	Minimum temperature collector 1	50 °F [10 °C]	42
OCN2	x	Option minimum limitation collector 2	OFF	42
CMN2	x*	Minimum temperature collector 2	50 °F [10 °C]	42
OCF1	x	Option antifreeze collector 1	OFF	42
CFR1	x*	Antifreeze temperature collector 1	40.0 °F [4.0 °C]	42
OCF2	x	Option antifreeze collector 2	OFF	42
CFR2	x*	Antifreeze temperature collector 2	40.0 °F [4.0 °C]	42
OTC	x	Option tube collector	OFF	44
TCST	x*	OTC starting time	07:00	44
TCEN	x*	OTC ending time	19:00	44
TCRU	x*	OTC runtime	30 s	44
TCIN	x*	OTC standstill interval	30 min	44
MAN1	x	Manual operation R1	Auto	46
MAN2	x	Manual operation R2	Auto	46
LANG	x	Language	En	46
UNIT	x	Temperature unit	°C	46
RESE	x	Reset - back to factory defaults		46
W0050100		Version number		

## Legend:

Symbol	Specification
x	Channel is available
x*	Channel is available if the corresponding option is activated.

**System layout 8**

The controller calculates the temperature difference between collector sensor S1 and tank sensor S2. If the difference is larger than or identical to the adjusted switch-on temperature difference (DT O), the solar pump will be operated by relay 1, and the tank will be loaded until the switch-off temperature difference (DT F) or the maximum tank temperature (S MX) is reached.

A solid fuel boiler will be operated by relay 2, if the temperature difference between sensors S4 and S3 is larger than or identical to the adjusted switch-on temperature difference (DT3O), until the adjusted minimum (MN3O) and maximum (MX3O) temperature thresholds of the fuel boiler and the tank are reached.

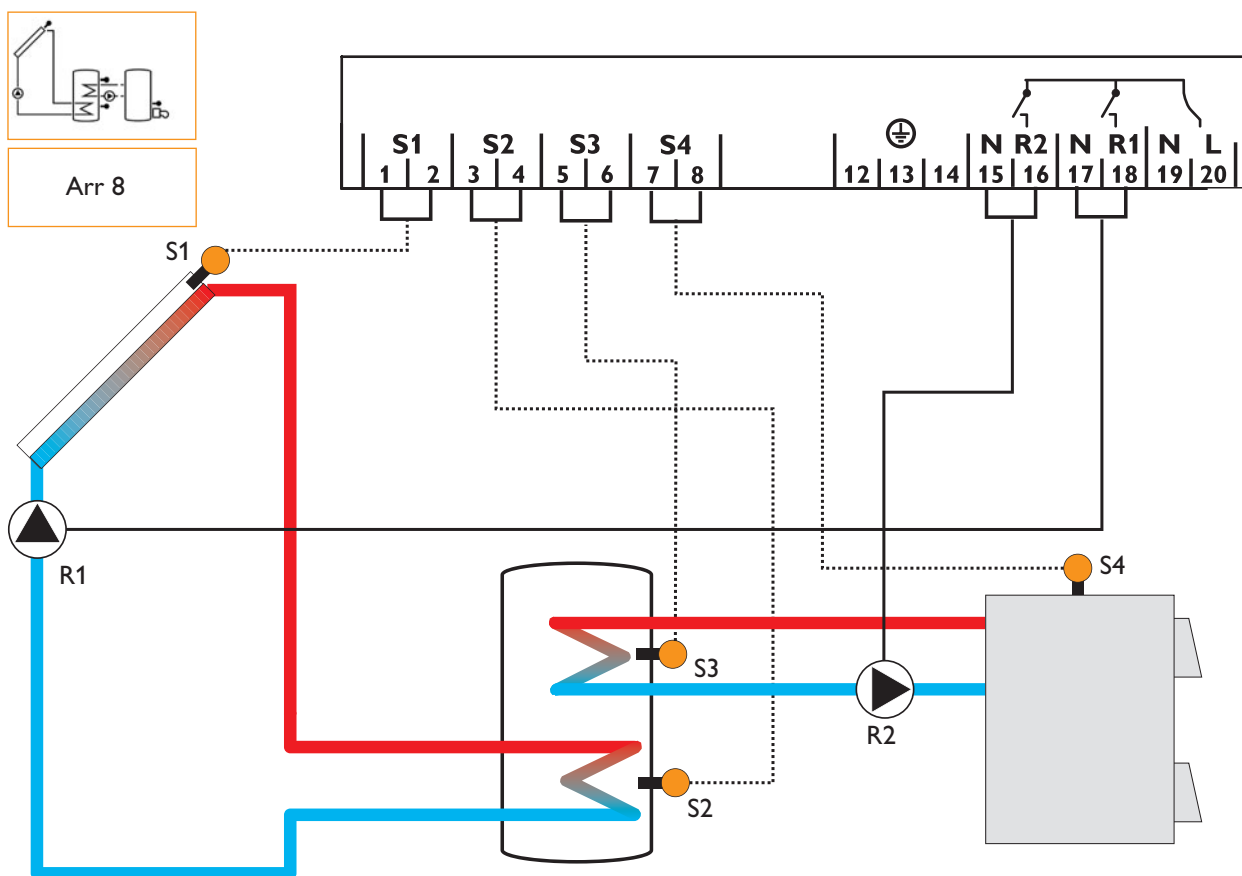

Display Channels				
Channel		Description	Terminal	Page
INIT	x*	ODB initialization active	-	37
FLL	x*	ODB filling time active	-	37
STAB	x*	ODB stabilization in progress	-	37
COL	x	Temperature collector	S1	37
TSTB	x	Temperature tank 1 bottom	S2	37
TSTT	x	Temperature tank 1 at the top	S3	37
TSFB	x	Temperature solid fuel boiler	S4	37
n1 %	x	Pump speed R1	R1	38
n2 %	x	Pump speed R2	R2	38
h P1	x	Operating hours R1	R1	38
h P2	x	Operating hours R2	R2	38
TIME	x	Time	-	34

Adjustment Channels				
Channel		Description	Factory setting	Page
Arr	x	System	8	39
DT O	x	Switch-on temperature difference	12.0 °Ra [6.0 K]	39
DT F	x	Switch-off temperature difference	8.0 °Ra [4.0 K]	39
DT S	x	Nominal temperature difference	20.0 °Ra [10.0 K]	39
RIS	x	Rise control R1	4 °Ra [2 K]	39
n1MN	x	Minimum pump speed R1	30 %	39
S MX	x	Maximum tank temperature	140 °F [60 °C]	40
n2MN	s	Minimum pump speed R2	30 %	26
EM	x	Emergency temperature collector	270 °F [130 °C]	40
		Emergency temperature collector if ODB is activated:	200 °F [95 °C]	40
OCC	x	Option collector cooling	OFF	41
CMX	x*	Maximum collector temperature	230 °F [110 °C]	41
OSYC	x	Option system cooling	OFF	41
DTCO	x*	Cooling switch-on temperature difference	40.0 °Ra [20.0 K]	41
DTCF	x*	Cooling switch-off temperature difference	30.0 °Ra [15.0 K]	41
OSTC	x	Option tank cooling	OFF	42
OHOL	x*	Option holiday cooling	OFF	42
THOL	x*	Holiday cooling temperature	110 °F [40 °C]	42
OCN	x	Option minimum limitation	OFF	42
CMN	x*	Minimum collector temperature	50 °F [10 °C]	42
OCF	x	Option antifreeze	OFF	42
CFR	x*	Antifreeze temperature	40.0 °F [4.0 °C]	42
OTC	x	Option tube collector	OFF	44
TCST	x*	OTC starting time	07:00	44
TCEN	x*	OTC ending time	19:00	44
TCRU	x*	OTC runtime	30 s	44
TCIN	x*	OTC standstill interval	30 min	44
DT3O	s	Switch-on temperature difference 3	12.0 °Ra [6.0 K]	26
DT3F	s	Switch-off temperature difference 3	8.0 °Ra [4.0 K]	26
DT3S	s	Nominal temperature difference 3	20.0 °Ra [10.0 K]	26
RIS3	s	Rise control R2	4 °Ra [2 K]	26
MX3O	s	Switch-on treshold for maximum temperature	140.0 °F [60.0 °C]	27
MX3F	s	Switch-off treshold for maximum temperature	136.0 °F [58.0 °C]	27
MN3O	s	Switch-on treshold for minimum temperature	140.0 °F [60.0 °C]	27
MN3F	s	Switch-off treshold for minimum temperature	150.0 °F [65.0 °C]	27
ODB	x	Drainback option	OFF	45
tDTO	x*	ODB switch-on condition - time period	60 s	45
tFLL	x*	ODB filling time	5.0 min	45
tSTB	x*	ODB stabilization time	2.0 min	45
MAN1	x	Manual operation R1	Auto	46
MAN2	x	Manual operation R2	Auto	46
LANG	x	Language	En	46
UNIT	x	Temperature unit	°C	46
RESE	x	Reset - back to factory defaults		46
W0050100		Version number		

**Legend:**

Symbol	Specification
x	Channel is available
x*	Channel is available if the corresponding option is activated.
s	Channel is specifically available in this system layout

**System-specific functions**

**ΔT control for backup heating by solid fuel boiler**

**DT30:**

Switch-on temperature diff.  
Adjustment range: 2.0 ... 40.0 °Ra  
[1.0 ... 20.0 K]  
in steps of 1 °Ra [0.5 K]  
Factory setting: 12.0 °Ra  
[6.0 K]



**DT3F:**

Switch-off temperature diff.  
Adjustment range: 1.0 ... 39.0 °Ra  
[0.5 ... 19.5 K]  
in steps of 1 °Ra [0.5 K]  
Factory setting: 8.0 °Ra  
[4.0 K]



**Pump speed control**

**DT3S:**

Nominal temperature difference  
Adjustment range: 3.0 ... 60.0 °Ra  
[1.5 ... 30.0 K]  
in steps of 1 °Ra [0.5 K]  
Factory setting: 20.0 °Ra  
[10.0 K]

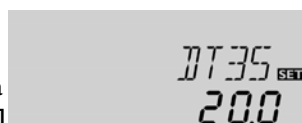

**RIS3:**

Rise  
Adjustment range:  
2 ... 40 °Ra [1 ... 20 K]  
in steps of 2 °Ra [1 K]  
Factory setting: 4 °Ra [2 K]



**Minimum pump speed**

**n2MN:**

Pump speed control  
Adjustment range:  
30 ... 100  
in steps of 5 %  
Factory setting: 30

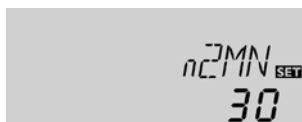

The following adjustments are used for the specific functions in system layout 8.

**Reference sensors for this function are S4 and S3.**

In system layout 8, the controller is equipped with an additional differential control for heat exchange from a solid fuel boiler (e.g. woodstove). The basic differential function is adjusted using the switch-on (**DT30**) and switch-off (**DT3F**) temperature differences.

When the switch-on difference is reached, relay 2 switches on. When the temperature difference falls below the adjusted switch-off temperature difference, relay 2 switches off.



**Note:**

The switch-on temperature difference must be at least 1 °Ra [0.5 K] higher than the switch-off temperature difference.



**Note:**

For pump speed control of the solid fuel boiler pump, the operation mode of relay 2 (**MAN2**) must be set to Auto.

When the switch-on temperature difference is reached, the pump is activated at full speed for 10 seconds. Then, the speed is reduced to the minimum pump speed value (**n2MN**). If the temperature difference reaches the adjusted nominal temperature difference (**DT3S**), the pump speed increases by one step (10 %). If the difference increases by the adjustable rise value, the pump speed increases by 10 % respectively until the maximum pump speed of 100 % is reached. The response of the controller can be adapted via the parameter **RIS3**.



**Note:**

The nominal temperature difference must be at least 1 °Ra [0.5 K] higher than the switch-on temperature difference.

A relative minimum pump speed can be allocated to the output R2 via the adjustment channel **n2MN**.



**Note:**

When loads which are not speed-controlled (e.g. valves) are used, the value must be set to 100 % in order to deactivate pump speed control.

### Maximum temperature limitation

#### MX3O / MX3F:

Maximum temperature limitation

Adjustment range:

30.0...200.0 °F

[0.0 ... 95.0 °C]

in steps of 1 °Ra [0.5 K]

Factory setting:

MX3O: 140.0 °F [60.0 °C]

MX3F: 136.0 °F [58.0 °C]

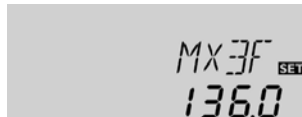

### Minimum temperature limitation

#### MN3O / MN3F:

Minimum temperature limitation

Adjustment range:

30.0...190.0 °F

[0.0 ... 90.0 °C]

in steps of 1 °Ra [0.5 K]

Factory setting (Arr = 8 only):

MN3O: 140.0 °F [60.0 °C]

MN3F: 150.0 °F [65.0 °C]

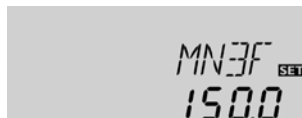

Minimum and maximum temperature limits can be set for the solid fuel boiler.

The maximum temperature limitation function provides a maximum temperature setting, usually to reduce scald risk in a storage tank. If **MX3O** is exceeded, relay 2 is switched off until the sensor falls below **MX3F**. In Arr 8, this function uses sensor 3 as reference sensor.

The minimum temperature limitation uses sensor 4 as reference sensor.

The minimum temperature limitation function provides a minimum temperature setting for the solid fuel boiler in system layout 8. If the temperature at sensor 4 falls below **MN3O**, relay 2 is switched off until the temperature exceeds **MN3F** again.

Both switch-on and switch-off temperature differences **DT3O** and **DT3F** are valid for the maximum and minimum temperature limitation.

**System layout 9**

The controller calculates the temperature difference between collector sensor S1 and tank sensor S2. If the difference is larger than or identical to the adjusted switch-on temperature difference (DT O), the solar pump will be operated by relay 1, and the tank will be loaded until the switch-off temperature difference (DT F) or the maximum tank temperature (S MX) is reached.

A heating circuit return preheating will be operated by relay 2, if the temperature difference between sensors S3 and S4 is larger than or identical to the adjusted switch-on temperature difference (DT3O). For this purpose, relay 2 will operate the 3-way-valve.

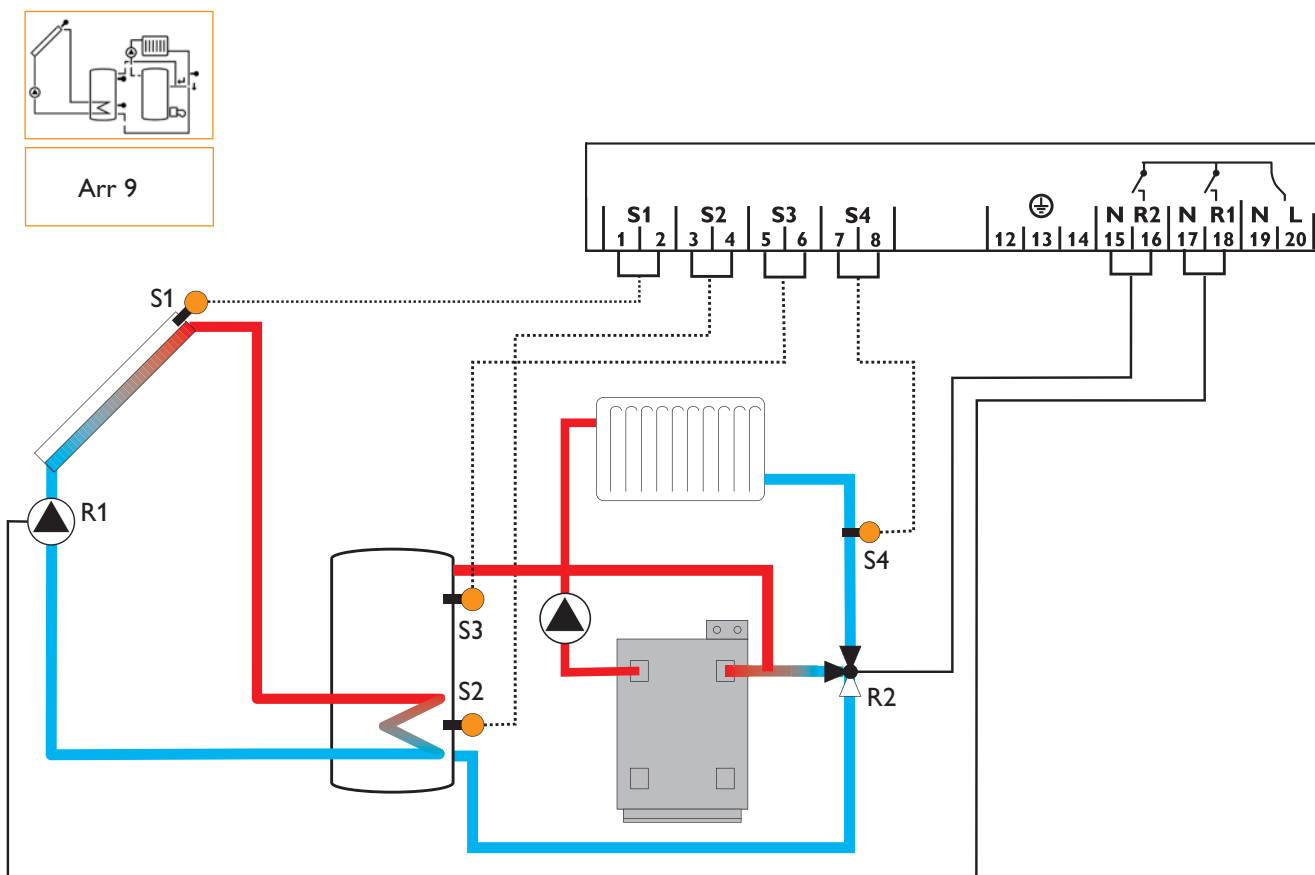

Display Channels				
Channel		Description	Terminal	Page
INIT	x*	ODB initialization active	-	37
FLL	x*	ODB filling time active	-	37
STAB	x*	ODB stabilization in progress	-	37
COL	x	Temperature collector	S1	37
TSTB	x	Temperature tank 1 bottom	S2	37
TSTT	x	Temperature tank 1 at the top	S3	37
TRET	x	Temperature heating circuit	S4	38
n %	x	Pump speed relay	R1	38
hP1	x	Operating hours R1	R1	38
hP2	x	Operating hours R2	R2	38
TIME	x	Time	-	34

Adjustment Channels				
Channel		Description	Factory setting	Page
Arr	x	System	9	39
DT O	x	Switch-on temperature difference	12.0 °Ra [6.0 K]	39
DT F	x	Switch-off temperature difference	8.0 °Ra [4.0 K]	39
DT S	x	Nominal temperature difference	20.0 °Ra [10.0 K]	39
RIS	x	Rise control R1	4 °Ra [2 K]	39
nMN	x	Minimum pump speed	30 %	39
S MX	x	Maximum tank temperature	140 °F [60 °C]	40
EM	x	Emergency temperature collector	270 °F [130 °C]	40
		Emergency temperature collector if ODB is activated:	200 °F [95 °C]	40
OCC	x	Option collector cooling	OFF	41
CMX	x*	Maximum collector temperature	230 °F [110 °C]	41
OSYC	x	Option system cooling	OFF	41
DTCO	x*	Cooling switch-on temperature difference	40.0 °Ra [20.0 K]	41
DTCF	x*	Cooling switch-off temperature difference	30.0 °Ra [15.0 K]	41
OSTC	x	Option tank cooling	OFF	42
OHOL	x*	Option holiday cooling	OFF	42
THOL	x*	Holiday cooling temperature	110 °F [40 °C]	42
OCN	x	Option minimum limitation	OFF	42
CMN	x*	Minimum collector temperature	50 °F [10 °C]	42
OCF	x	Option antifreeze	OFF	42
CFR	x*	Antifreeze temperature	40.0 °F [4.0 °C]	42
OTC	x	Option tube collector	OFF	44
TCST	x*	OTC starting time	07:00	44
TCEN	x*	OTC ending time	19:00	44
TCRU	x*	OTC runtime	30 s	44
TCIN	x*	OTC standstill interval	30 min	44
DT3O	s	Switch-on temperature difference 3	12.0 °Ra [6.0 K]	39
DT3F	s	Switch-off temperature difference 3	8.0 °Ra [4.0 K]	39
ODB	x	Drainback option	OFF	45
tDTO	x*	ODB switch-on condition - time period	60 s	45
tFLL	x*	ODB filling time	5.0 min	45
tSTB	x*	ODB stabilization time	2.0 min	45
MAN1	x	Manual operation R1	Auto	46
MAN2	x	Manual operation R2	Auto	46
LANG	x	Language	En	46
UNIT	x	Temperature unit	°C	46
RESE	x	Reset - back to factory defaults		46
W0050100		Version number		

**Legend:**

Symbol	Specification
x	Channel is available
x*	Channel is available if the corresponding option is activated.
s	Channel is specifically available in this system layout

**System layout 10**

The controller calculates the temperature difference between collector sensor S1 and tank sensor S2. If the difference is larger than or identical to the adjusted switch-on temperature difference (DT O), the solar pump will be operated by relay 1, and the tank will be loaded until the switch-off temperature difference (DT F) or the maximum tank temperature (S MX) is reached. If the maximum collector temperature (CMX) is reached, the solar pump will be operated by relay 1 and the 3-way-valve

will be operated by relay 2 in order to direct the surplus energy to a heat dump. For security purpose this will be carried out only if the tank temperature is below the non-adjustable emergency shutdown of 200 °F. Sensors S3 and S4 can optionally be connected for measurement purposes. If energy metering (OHQM) is activated, sensor S4 has to be connected as return sensor.

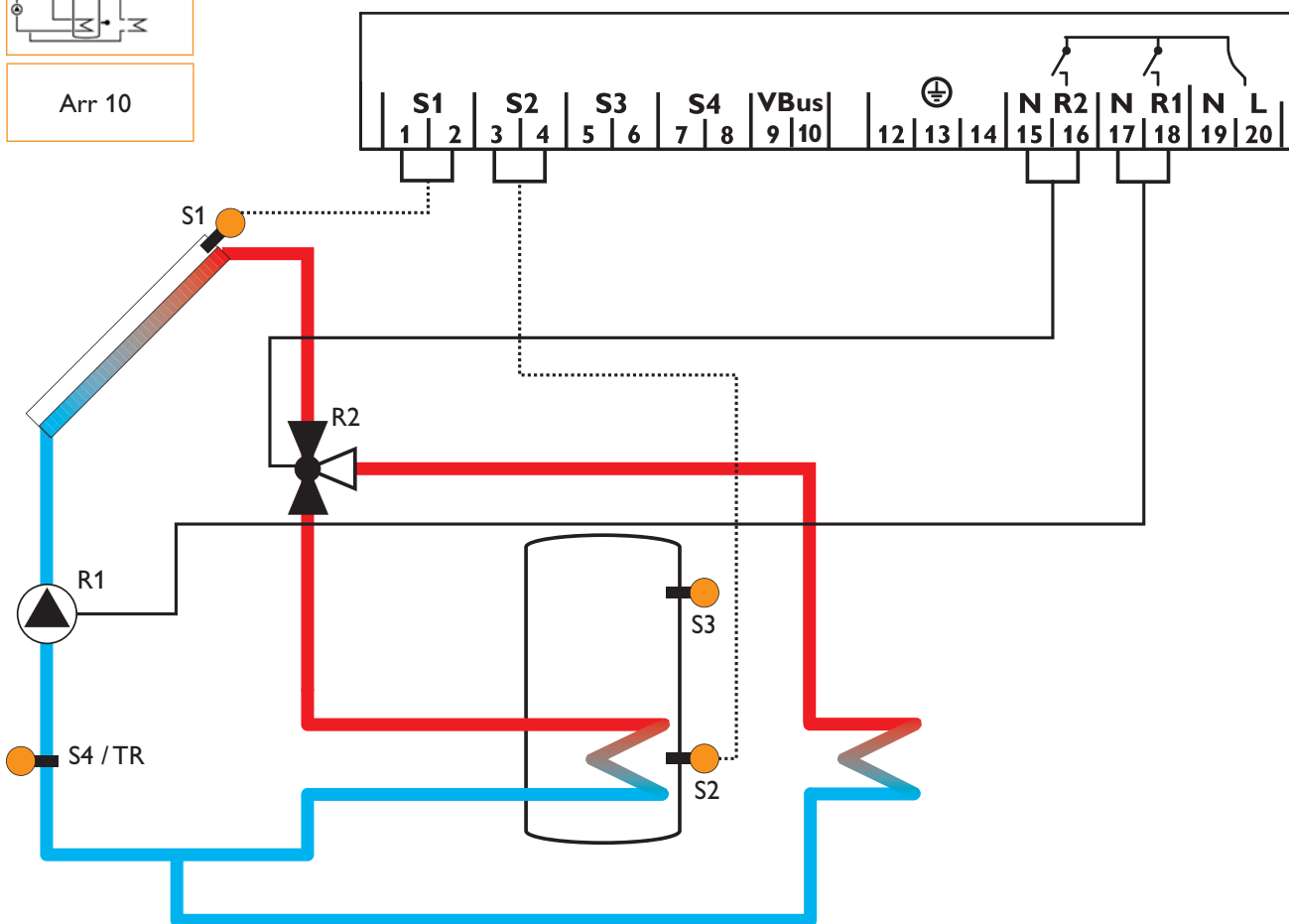
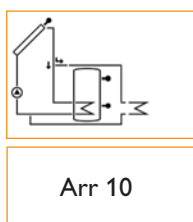

Display Channels				
Channel		Description	Terminal	Page
COL	x	Temperature collector	S1	37
TST	x	Temperature tank	S2	37
S3	x	Temperature sensor 3	S3	37
S4	x	Temperature sensor 4	S4	37
TR	x*	Temperature return sensor	S4	37
n %	x	Pump speed relay	R1	30
h P1	x	Operating hours R1	R1	38
h P2	x	Operating hours R2	R2	38
kWh	x*	Heat quantity kWh	-	38
MWh	x*	Heat quantity MWh	-	38
TIME	x	Time	-	34

Adjustment Channels				
Channel		Description	Factory setting	Page
Arr	x	System	10	39
DT O	x	Switch-on temperature difference	12.0 °Ra [6.0 K]	39
DT F	x	Switch-off temperature difference	8.0 °Ra [4.0 K]	39
DT S	x	Nominal temperature difference	20.0 °Ra [10.0 K]	39
RIS	x	Rise control R1	4 °Ra [2 K]	39
nMN	x	Minimum pump speed	30 %	39
S MX	x	Maximum tank temperature	140 °F [60 °C]	40
EM	x	Emergency temperature collector	270 °F [130 °C]	40
CMX	s	Maximum collector temperature	230 °F [110 °C]	41
OCN	x	Option minimum limitation	OFF	42
CMN	x*	Minimum collector temperature	50 °F [10 °C]	42
OCF	x	Option antifreeze	OFF	42
CFR	x*	Antifreeze temperature	40.0 °F [4.0 °C]	42
OTC	x	Option tube collector	OFF	44
TCST	x*	OTC starting time	07:00	44
TCEN	x*	OTC ending time	19:00	44
TCRU	x*	OTC runtime	30 s	44
TCIN	x*	OTC standstill interval	30 min	44
OHQM	x	Option energy metering	OFF	44
FMAX	x*	Maximum flow	6.0 l	44
MEDT	x*	Antifreeze type	1	44
MED%	x*	Antifreeze concentration (only if MEDT = propylene or ethylene)	45 %	44
MAN1	x	Manual operation R1	Auto	46
MAN2	x	Manual operation R2	Auto	46
LANG	x	Language	En	46
UNIT	x	Temperature unit	°C	46
RESE	x	Reset - back to factory defaults		46
W0050100		Version number		

**Legend:**

Symbol	Specification
x	Channel is available
x*	Channel is available if the corresponding option is activated.
s	Channel is specifically available in this system layout

## 2. Operation and function

### 2.1 Push buttons

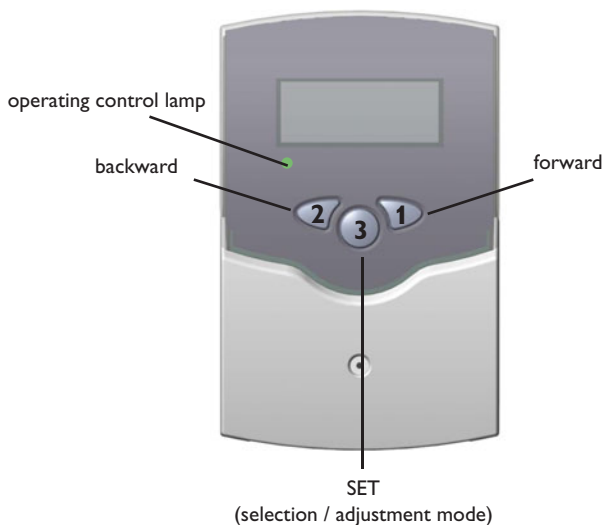

The controller is operated via three push buttons below the display. Button 1 is used for scrolling forward through the indication menu or to increase the adjustment values. Button 2 is used for scrolling backward and reducing values.

During normal operation, only the display channels are shown.

→ Scroll through the display channels by pressing buttons 1 and 2

#### Accessing the adjustment channels:

→ Scroll down in the display menu and press the forward button (1) for approx. two seconds after you have reached the last display item.

When an **adjustment value** is shown on the display, **SET** is indicated to the right of the channel name.

→ Press the “Set” button (3) in order to access the adjustment mode

**SET** starts flashing.

→ Adjust the value using buttons 1 and 2

→ Briefly press button 3, **SET** permanently appears, the adjusted value will be saved.

### 2.2 System monitoring display

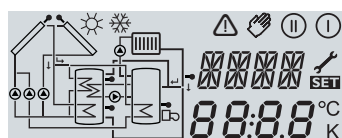

system monitoring display

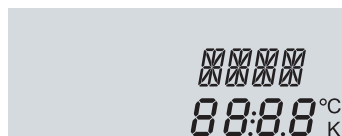

channel display

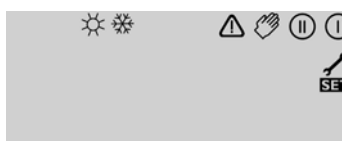

tool bar

The system monitoring display consists of three blocks: **channel display**, **tool bar** and **system screen** (active system layout).

The **channel display** consists of two lines. The upper line is an alpha-numeric 16-segment display (text display) for displaying channel names and menu items. In the lower 7-segment display, the channel values and the adjustment parameters are displayed.

Temperatures are either indicated in °F or °C, whereas temperature differences are indicated in K or °Ra respectively.

The additional symbols of the **tool bar** indicate the current system status.

Status	standard	flashing
relay 1 active	ⓘ	
relay 2 active	Ⓜ	
maximum tank temperature exceeded	☀	
tank emergency shutdown active		⚠ + ☀
collector emergency shutdown active		⚠
collector cooling active	ⓘ	☀
system cooling active	ⓘ	☀
tank cooling active	ⓘ + ☀	
holiday cooling function activated	☀	⚠
holiday cooling function active	ⓘ + ☀	⚠
collector minimum limitation active		❄
antifreeze function activated	❄	
antifreeze function active	ⓘ / Ⓜ	❄
manual operation relay 1 ON	☞ + ⓘ	⚠
manual operation relay 2 ON	☞ + Ⓜ	⚠
manual operation relay 1 / 2 OFF	☞	⚠
sensor defective	🔧	⚠

### System screen

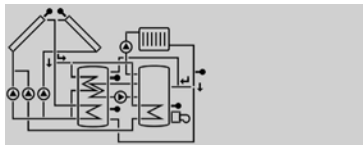

system screen

The system screen (active system layout) shows the system selected on the controller. It consists of several system component symbols, which are – depending on the current status of the system – either flashing, permanently shown or hidden.

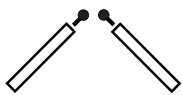
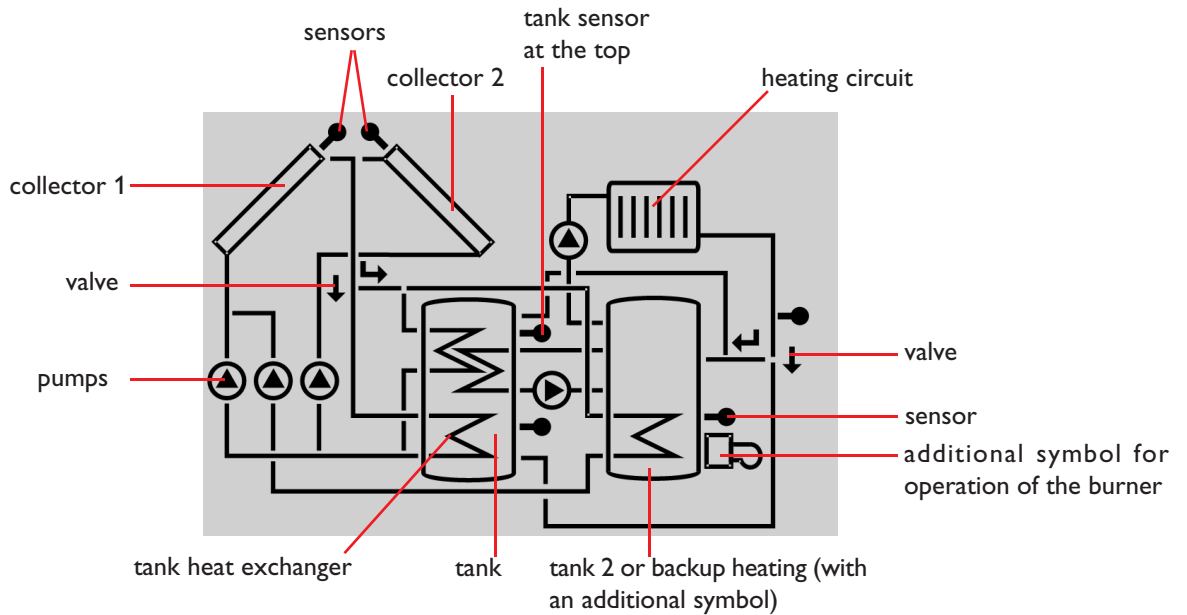

**Collectors**  
with collector sensor

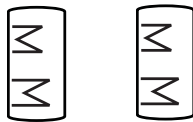

**Tanks 1 and 2**  
with heat exchanger



**3-way valve**  
The flow direction or the actual switching position is shown



**Temperature sensor**



**Heating circuit**



**Pump**

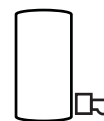

**Backup heating**  
with burner symbol

## 2.3 Flashing codes

### System screen flashing codes

- Pumps are flashing during initialization phase
- Sensor symbols are flashing if the corresponding sensor display channel is selected.
- Sensors are flashing in the case of a sensor fault.
- Burner symbol is flashing if the backup heating is active

### LED flashing codes

- |                    |                                     |
|--------------------|-------------------------------------|
| green:             | everything OK                       |
| red/green flashing | initialization phase                |
|                    | manual operation                    |
| red flashing:      | sensor fault                        |
|                    | (sensor symbol is flashing quickly) |

### 3. Commissioning



The three pushbuttons of the BS Plus controller

→ Establish the power supply

During a short initialization phase, the operating control lamp flashes red and green.

When the controller is commissioned for the first time or after a reset, it will run a commissioning menu. The commissioning menu leads the user through the most important adjustment channels needed for operating the system.

#### Operating the commissioning menu:

→ Enter the channel by pressing button 3

The **SET** symbol flashes.

→ Adjust the value by pressing buttons 1 and 2

→ Save the adjustment by pressing button 3 again

The **SET** symbol stops flashing.

→ Press button 1 or 2 to switch to the next or previous channel

The commissioning menu consists of the following 6 channels:

#### LANG:

Language selection

Selection: dE,En

Factory setting: En



#### 1. Language

→ Adjust the desired menu language in this channel

- dE : German
- En : English

#### UNIT:

Temperature unit selection

Selection: °F, °C

Factory setting: °C



#### 2. Unit

→ Adjust the unit in which temperatures and temperature differences shall be displayed

#### TIME:

Real time adjustment

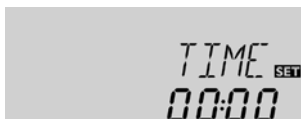

#### 3. Time

→ Adjust the current time for the real time clock

The hours and minutes have to be adjusted separately, first the hours, then the minutes.

**Arr:**

System layout selection  
Adjustment range: 1 ... 10  
Factory setting: 1



**4. System layout**

➔ Adjust the desired system layout of your solar thermal system

For a detailed description of the different system layouts selectable, see chapter 1.4.

**Overview of system layouts:**

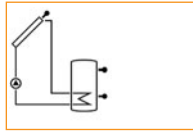

Arr 1

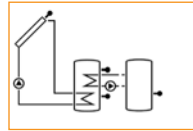

Arr 2

Arr 1 : standard solar system layout

Arr 2 : solar system layout with heat exchange

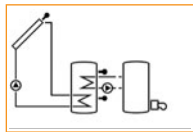

Arr 3

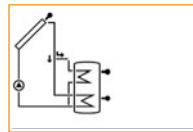

Arr 4

Arr 3 : solar system layout with backup heating

Arr 4 : solar system layout with vertical tank charging

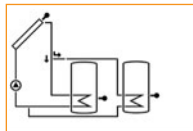

Arr 5

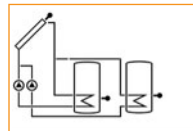

Arr 6

Arr 5 : 2-tank solar system layout with valve logic

Arr 6 : 2-tank solar system layout with pump logic

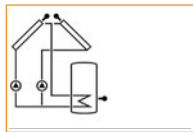

Arr 7

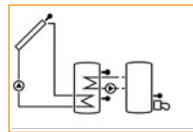

Arr 8

Arr 7 : solar system layout with 2 collectors and 1 tank

Arr 8 : solar system layout with backup heating by solid fuel boiler

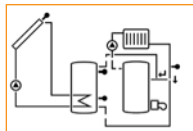

Arr 9

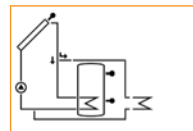

Arr 10

Arr 9 : solar system layout with heating circuit return preheating

Arr 10: standard solar system layout with heat dump

If the system layout selection is changed later on, any previous adjustments which have been made in the other channels will be lost. Therefore, changing the system layout is always followed by a security enquiry.

**Only confirm the security enquiry if you are sure that you wish to change the system layout selection!**

**Security enquiry:**

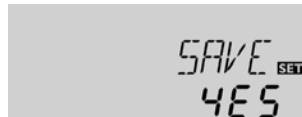

➔ To confirm the security enquiry, press button 3

**S MX / S1MX / S2MX:**

Maximum tank temp.  
Adjustment range:  
40 ... 200 °F [4 ... 95 °C]  
Arr 10:  
40 ... 190 °F [4 ... 90 °C]  
in steps of 2 °Ra [1 K]  
Factory setting: 140 °F [60 °C]

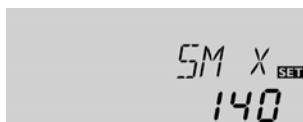

**5. Maximum tank temperature**

→ Adjust the desired maximum tank temperature



**Note:**  
The controller is also equipped with a non-adjustable emergency shutdown function, which will shut the system down if the tank reaches 200 °F [95 °C].

**nMN, n1MN, n2MN:**

Pump speed control  
Adjustment range:  
30 ... 100  
in steps of 5 %  
Factory setting: 30

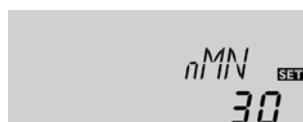

**6. Minimum pump speed**

→ Adjust a minimum speed for the pump



**Note:**  
If loads which are not speed-controlled (e.g. valves) are used, the value must be set to 100 % for the respective relay.

**Confirmation enquiry**



**Completing the commissioning menu**

After the last channel of the commissioning menu has been adjusted and confirmed, the controller asks for confirmation of the adjustments.

→ To confirm the adjustments made in the commissioning menu, press button 3

Now the controller is ready for operation with typical settings to suit the selected system layout.

The settings made in the commissioning menu can be changed later on in the corresponding adjustment channels. Additional functions and options can of course be individually adjusted as well (see chap. 4.2).

## 4. Channel overview

### 4.1 Display channels

#### Indication of drainback time periods

##### Initialization

**INIT:**  
ODB initialization active

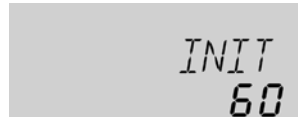

##### Filling time

**FLL:**  
ODB filling time active



##### Stabilization

**STAB:**  
Stabilization

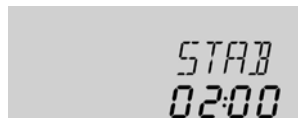

#### Indication of collector temperatures

**COL, COL1, COL2:**  
Collector temperature  
Display range: -40...+500 °F  
[-40...+260 °C]



#### Indication of tank temperatures

**TST, TSTB, TSTT, TST1, TST2, TDIS:**  
Tank temperatures  
Display range: -40...+500 °F  
[-40...+260 °C]

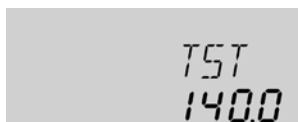

#### Indication of sensors 3 and 4

**S3, S4:**  
Sensor temperatures  
Display range: -40...+500 °F  
[-40...+260 °C]

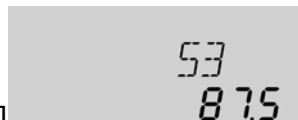

#### Indication of other temperatures

**TSFB, TRET, TR:**  
Other measured temperatures  
Display range: -40...+500 °F  
[-40...+260 °C]

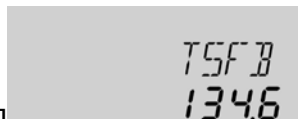

**Note:**

The displayed values and adjustment channels depend on which system layout, which options and functions have been selected. Only values and adjustment channels available for the individual settings selected will appear in the menu.

Indicates the time adjusted in **tD<sub>TO</sub>**, running backwards.

Indicates the time adjusted in **tF<sub>LL</sub>**, running backwards.

Indicates the time adjusted in **tS<sub>TB</sub>**, running backwards.

Indicates the current collector temperature.

- COL : collector temperature (1-collector system)
- COL1: collector temperature 1
- COL2: collector temperature 2

Indicates the current tank temperature.

- TST : tank temperature (1-tank system)
- TSTB : tank temperature bottom
- TSTT : tank temperature top (Arr = 3 and 4 only)
- TST1 : temperature tank 1 (2-tank-systems)
- TST2 : temperature tank 2 (2-tank-systems)
- TDIS : thermal disinfection temperature (Arr = 3 only; replaces TSTT if, during thermal disinfection, the heating period DDIS is active)

Indicates the current temperature of the corresponding additional sensor (without control function).

- S3 : temperature sensor 3
- S4 : temperature sensor 4



**Note:**

S3 and S4 will only be indicated if the temperature sensors are connected.

Indicates the current temperature of the corresponding sensor.

- TSFB : temperature solid fuel boiler
- TRET : temperature heating return preheating
- TR : temperature return

**Indication of current pump speed**

**n % , n1 % , n2 %:**

Current pump speed  
Display range: 30 ... 100 %

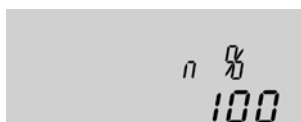

**kWh/MWh:** Heat quantity

in kWh / MWh

Display channel



Indicates the current pump speed of the corresponding pump.

- n % : current pump speed (1-pump system)
- n1 % : current pump speed pump 1
- n2 % : current pump speed pump 2

Indicates the energy gained in heat quantity – only available if energy metering (OHQM) is activated.

The flow rate as well as the reference sensors S1 (flow) and S4 (return) are used for calculating the heat quantity supplied. It is shown in kWh in the channel **kWh** and in MWh in the channel **MWh**. The overall heat quantity results from the sum of both values.

The accumulated heat quantity can be reset. As soon as one of the display channels of the heat quantity is selected, the **SET** symbol is permanently shown on the display.

➔ Press button SET (3) for about two seconds in order to access the RESET mode of the counter.

The display symbol **SET** will flash and the heat quantity value will be set to 0.

➔ In order to finish this process, press the **SET** button to confirm.

In order to interrupt the RESET process, no button should be pressed for about five seconds. The controller automatically returns to the display mode.

**CDIS**

Countdown of monitoring period

Display range:  
0 ... 30:0 ... 24 (dd:hh)



If the thermal disinfection option (**OTD**) is activated and the monitoring period is in progress, the remaining monitoring time will be displayed as **CDIS** (in days and hours) and counted backwards.

**SDIS**

Starting time display

Display range:  
00:00 ... 24:00 (hh:mm)

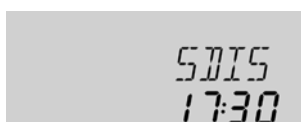

If the thermal disinfection option (**OTD**) is activated and a starting delay time has been adjusted, the adjusted delay time is displayed (flashing) in this channel.

**DDIS**

Heating period display

Display range:  
00:00 ... 24:00 (hh:mm)



If the thermal disinfection option (**OTD**) is activated and the heating period is in progress, the remaining time of the heating period is displayed (in hours and minutes) in this channel, counting backwards.

**Time**

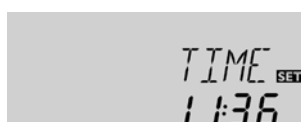

Indicates the actual time.

Press the **SET** button for two seconds in order to adjust the hours. Press it again in order to adjust the minutes. Set the time by pressing buttons 1 and 2. Press the **SET** button in order to save the adjustment.

**Operating hours counter**

**h P / h P1 / h P2:**

Operating hours counter  
Display channel

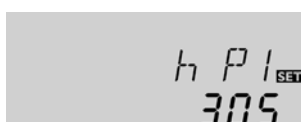

The operating hours counter accumulates the solar operating hours of the respective relay (**h P / h P1 / h P2**). Full hours are displayed.

The accumulated operating hours can be set back to zero. As soon as one operating hours channel is selected, the symbol **SET** is displayed.

➔ In order to access the RESET-mode of the counter, press the SET button (3) for approx. two seconds.

The display symbol **SET** will flash and the operating hours will be set to 0.

➔ Confirm the reset with the **SET** button in order to finish the reset.

In order to interrupt the RESET-process, do not press a button for about five seconds. The display returns to the display mode.

## 4.2 Adjustment channels

### System layout selection

**Arr:**

System layout selection.  
Adjustment range: 1 ... 10  
Factory setting: 1



**Security enquiry:**



### ΔT-regulation

**DT O / DT10 / DT20 / DT30:**

Switch-on temperature diff.  
Adjustment range: 2.0 ... 40.0 °Ra  
[1.0 ... 20.0 K]  
in steps of 1 °Ra [0.5 K]  
Factory setting: 12.0 °Ra  
[6.0 K]



**DT F / DT1F / DT2F / DT3F:**

Switch-off temperature diff.  
Adjustment range: 1.0 ... 39.0 °Ra  
[0.5 ... 19.5 K]  
in steps of 1 °Ra [0.5 K]  
Factory setting: 8.0 °Ra  
[4.0 K]



### Pump speed control

**DT S / DT1S / DT2S / DT3S:**

Nominal temperature difference  
Adjustment range: 3.0 ... 60.0 °Ra  
[1.5 ... 30.0 K]  
in steps of 1 °Ra [0.5 K]  
Factory setting: 20.0 °Ra  
[10.0 K]

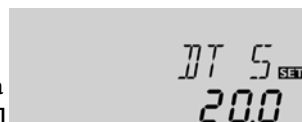

**RIS / RIS1 / RIS2 / RIS3:**

Rise  
Adjustment range:  
2 ... 40 °Ra [1 ... 20 K]  
in steps of 2 °Ra [1 K]  
Factory setting: 4 °Ra [2 K]



### Minimum pump speed

**nMN, n1MN, n2MN:**

Pump speed control  
Adjustment range:  
30 ... 100  
in steps of 5 %  
Factory setting: 30

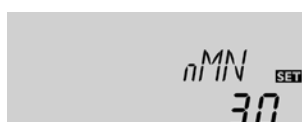

In this channel, a pre-defined system layout can be selected. Each system layout has a set of pre-programmed settings that can be individually changed.

If the system layout selection is changed later on, all adjustments made in the other channels will be lost. Therefore, changing the system layout is always followed by a security enquiry.

**Only confirm the security enquiry if you are sure that you wish to change the system layout selection!**

➔ To confirm the security enquiry, press button 3

The controller works as a standard differential controller. If the switch-on difference is reached, the pump is activated. When the temperature difference falls below the adjusted switch-off temperature difference, the respective relay switches off.



**Note:**

The switch-on temperature difference must be at least 1 °Ra [0.5 K] higher than the switch-off temperature difference.



**Note:**

When the drainback option **ODB** is activated, the temperature differences **DT O**, **DT F** and **DT S** are set to a fixed adjustment:

DT O = 20 °Ra [10 K]  
DT F = 8 °Ra [4 K]  
DT S = 30 °Ra [15 K]

Previous adjustments made in these channels will be overridden and may have to be entered again if **ODB** is deactivated later on.



**Note:**

For pump speed control, the operation mode of the corresponding relay must be set to Auto (adjustment channel **MAN1** / **MAN2**)

When the switch-on temperature difference is reached, the pump is activated at full speed for 10 seconds. Then, the speed is reduced to the minimum pump speed value (factory setting = 30 %).

If the temperature difference reaches the adjusted nominal temperature difference, the pump speed increases by one step (10 %). If the difference increases by the adjustable rise value, the pump speed increases by 10 % respectively until the maximum pump speed of 100 % is reached. The response of the controller can be adapted via the parameter "Rise".



**Note:**

The nominal temperature difference must be at least 1 °Ra [0.5 K] higher than the switch-on temperature difference.

A relative minimum pump speed can be allocated to the outputs R1 and R2 via the adjustment channels **nMN**, **n1MN** and **n2MN**.



**Note:**

When loads which are not speed-controlled (e.g. valves) are used, the value must be set to 100 % in order to deactivate pump speed control.

**Maximum tank temperature**

**S MX / S1MX / S2MX:**

Maximum tank temp.

Adjustment range:

40 ... 200 °F [4 ... 95 °C]

Arr 10:

40 ... 190 °F [4 ... 90 °C]

in steps of 2 °Ra [1 K]

Factory setting: 140 °F [60 °C]

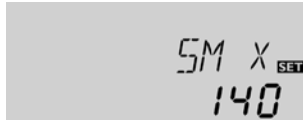

Once the adjusted maximum temperature is exceeded, the solar pump is switched off and further loading of the tank is prevented to reduce scald risk or system damage. A fixed hysteresis of 4 °Ra [2 K] is set for the maximum tank temperature.

When the temperature at the corresponding sensor exceeds the adjusted maximum tank temperature, the ☀ symbol is shown on the display.



**Note:**

If the collector cooling or the system cooling function is activated, the adjusted tank temperature may be overridden. In order to prevent system damage, the controller is also equipped with a non-adjustable emergency shutdown if the tank reaches 200 °F [95 °C].

**Collector temperature limitation**

**Emergency shutdown of the collector**

**EM / EM1 / EM2:**

Collector temperature limitation

Adjustment range:

170 ... 390 °F

[80 ... 200 °C]

in steps of 2 °Ra [1 K]

Factory setting:

270 °F [130 °C]



If the adjusted collector emergency shutdown temperature (**EM / EM1 / EM2**) is exceeded, the controller switches off the solar pump (R1 / R2) in order to protect the system against overheating (collector emergency shutdown). A hysteresis of 20 °Ra [10 K] is set for the collector temperature limitation. While the collector is in emergency shutdown, Δ (flashing) is shown on the display.



**Note:**

If the drainback option **ODB** is activated, the adjustment range of **EM** is changed to 170 ... 250 °F [80 ... 120 °C]. The factory setting in that case is 200 °F [95 °C].

<p><b>WARNING!</b></p> 	<p><b>Danger of injury and system damage through pressure surges!</b></p> <p>If water is used as a heat transfer medium in a pressure-less system, the water will start boiling at 212 °F [100 °C].</p> <p>➔ <b>If a pressure-less drainback system is used with water as a heat transfer medium, do not adjust the collector temperature limitation EM to more than 200 °F [95 °C]!</b></p>
--	--

**Cooling functions**

In the following the three cooling functions – collector cooling, system cooling and tank cooling – are described in detail. The following notes are valid for all three cooling functions:



**Note:**

The cooling functions will not become active as long as solar loading is possible.



**Note:**

In 2-tank-systems, the cooling functions will only affect tank 1, respectively the bottom area of the tank (such as in Arr = 4).

**Collector cooling function**

**OCC / OCC1 / OCC2:**

Option collector cooling  
Adjustment range: OFF/ON  
Factory setting: OFF



**CMX / CMX1 / CMX2:**

Maximum collector temp.  
Adjustment range:  
150...320 °F  
[70 ... 160 °C]  
in steps of 1 °Ra [1 K]  
Factory setting:  
230 °F [110 °C]



When the collector cooling function is activated, the controller aims to keep the collector at an operational temperature. When the adjusted maximum tank temperature is reached, solar loading stops. If the collector temperature increases to the adjusted maximum collector temperature, the solar pump is activated until the collector temperature falls at least 10 °Ra [5 K] below the maximum collector temperature. The tank temperature may increase (subordinate active maximum tank temperature), but only up to 200°F [95 °C] (emergency shutdown of the tank). If the collector cooling function is active, ☉ and ✨ (flashing) is shown on the display.



**Note:**

This function will only be available if the system cooling function (**OSYC**) is deactivated.



**Note:**

In system layout 10, the parameter **CMX** is available without the **OCC** function. In system layout 10, **CMX** is used to set the activation temperature for the heat dump function. No other switch-on condition is needed in that case.

**System cooling function**

**OSYC:**

Option system cooling  
Adjustment range: OFF/ON  
Factory setting: OFF

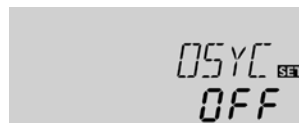

**DTCO:**

Switch-on temperature diff.  
Adjustment range:  
2.0 ... 60.0 °Ra  
[1.0 ... 30.0 K]  
in steps of 1 °Ra [0.5 K]  
Factory setting:  
40.0°Ra [20.0 K]



**DTCF:**

Switch-off temperature diff.  
Adjustment range:  
1.0 ... 59.0°Ra  
[0.5 ... 29.5 K]  
in steps of 1 °Ra [0.5 K]  
Factory setting:  
30.0°Ra [15.0 K]



When the system cooling function is activated, the controller aims to keep the solar system operational for a longer time. The function overrides the maximum tank temperature to provide thermal relief of the collector field and the heat transfer fluid on hot days. If the tank temperature is higher than the maximum tank temperature (**S MX / S1MX**) and the switch-on temperature difference **DTCO** is reached, the solar system remains activated. Solar loading is continued until either the tank temperature reaches 200 °F [95 °C] (emergency shutdown of the tank), the temperature difference falls below the adjusted value **DTCF** or the collector emergency shutdown temperature **EM** is reached. If the system cooling function is active, ☉ and ✨ (flashing) is shown on the display.



**Note:**

This function will only be available if the collector cooling function (**OCC**) is deactivated.

### Tank cooling function

#### OSTC:

Tank cooling option  
Adjustment range: OFF/ON  
Factory setting: OFF



#### OHOL:

Holiday cooling option  
Adjustment range: OFF/ON  
Factory setting: OFF



#### THOL:

Holiday cooling temperature  
Adjustment range:  
70 ... 175 °F  
[20 ... 80 °C]  
in steps of 1 °F [1 °C]  
Factory setting:  
110 °F [40 °C]

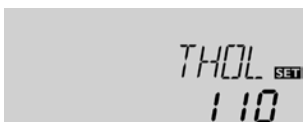

### Collector minimum limitation option

#### OCN / OCN1 / OCN2:

Collector minimum limitation  
Adjustment range: OFF / ON  
Factory setting: OFF



#### CMN / CMN1 / CMN2:

Collector minimum temp.  
Adjustment range:  
50...190 °F  
[10 ... 90 °C]  
in steps of 1 °Ra [0.5 K]  
Factory setting:  
50 °F [10 °C]



### Antifreeze option

#### OCF / OCF1 / OCF2:

Antifreeze function  
Adjustment range: OFF / ON  
Factory setting: OFF



#### CFR / CFR1 / CFR2:

Antifreeze temperature  
Adjustment range:  
-40.0 ... +50.0 °F  
[-40.0 ... +10.0 °C]  
in steps of 1 °Ra [0.5 K]  
Factory setting:  
40.0 °F [4.0 °C]



When the tank cooling function is activated, the controller aims to cool down the tank during the night in order to prepare it for solar loading on the following day.

If the adjusted maximum tank temperature (**S MX / S1MX**) is exceeded and the collector temperature falls below the tank temperature, the system will be reactivated in order to cool down the tank. Cooling will continue until the tank temperature has fallen below the adjusted maximum tank temperature (**S MX / S1MX**) again. A fixed hysteresis of 4 °Ra [2 K] is set for this function.

Reference threshold temperature differences for the tank cooling function are **DT O** and **DT F**.

If no DHW consumption is expected for a longer period of time, the additional holiday cooling option **OHOL** can be activated in order to extend the tank cooling function. The adjustable temperature **THOL** then replaces the maximum tank temperature (**S MX / S1MX**) as a switch-off temperature for the tank cooling function.

When the holiday cooling function is activated, ☀ and ⚠ (flashing) are shown on the display.

While the holiday cooling function is active, ⌚, ☀ and ⚠ (flashing) are shown on the display.

If the collector minimum limitation option is activated, the pump (R1 / R2) is only switched on if the adjustable collector minimum temperature is exceeded. The minimum temperature prevents the pump from being switched on too often at low collector temperatures. A fixed hysteresis of 10 °Ra [5 °K] is set for this function.

If the collector minimum limitation is active, ☀ (flashing) is shown on the display.



#### Note:

If **OSTC** or **OCF** is active, the collector minimum function will be overridden. In that case, the collector temperature may fall below **CMN**.

The antifreeze function activates the loading circuit between the collector and the tank when the temperature falls below the adjusted antifreeze temperature. This will protect the fluid against freezing or coagulating. If the adjusted antifreeze temperature is exceeded by 2 °Ra [1 K], the loading circuit will be deactivated.

When the antifreeze function is activated, ☀ is shown on the display. If the antifreeze function is active, ⌚ and ☀ (flashing) are shown on the display.



#### Note:

Since this function uses the limited heat quantity of the tank, the antifreeze function should be used in regions with few days of temperatures around the freezing point.

The antifreeze function will be suppressed if the tank temperature falls below 40 °F [5 °C] in order to protect the tank from frost damage.

### The iSOLAR PLUS priority logic



**Note:**  
Priority logic can be used in multi-tank system layouts only (Arr = 4, 5, 6).

#### **PRIO:**

Loading priority  
Adjustment range:  
SE 1, SE 2, Su 1, Su 2, 0, 1, 2  
Factory setting:  
Arr 4: 2  
Arr 5, 6: 1



**Note:**  
If the priority is set to **Su 1** or **Su 2**, solar loading of the subordinate tank will be aborted at once if the temperature in the priority tank (tank 1 for Su 1, tank 2 for Su 2) falls below the adjusted maximum temperature. If, in that case, the temperature difference between the priority tank and the collector is not sufficiently high, solar loading will be stopped completely.

#### **Spreaded loading temperature difference**

(only available if PRIO is set to SE 1 or SE 2)

#### **DTSE:**

Spread temperature difference  
Adjustment range:  
40 ... 160 °Ra  
[20 ... 90 K]  
in steps of 1 °Ra [1 K]  
Factory setting: 70 °Ra [40 K]



#### **Tank sequence control**

(only available if priority is set to SE 1, SE 2, 1 or 2)

#### **tLB:**

Loading break time  
Adjustment range: 1 ... 30 min  
Factory setting: 2 min

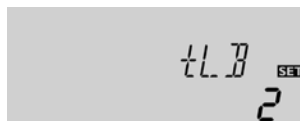

#### **tRUN:**

Loading runtime  
Adjustment range: 1 ... 30 min  
Factory setting: 15 min



If a multi-tank system layout has been chosen, the priority logic determines how the heat is divided between the tanks. Different types of priority logic are adjustable:

- spreaded loading (SE 1 and SE 2)
- successive loading (Su 1 and Su 2)
- parallel loading (0)
- tank sequence control (1 and 2)

If **priority SE 1** or **SE 2** (only available in Arr 6) is adjusted, the subordinate tank will be loaded in parallel if the temperature difference between the collector and the priority tank (tank 1 for SE 1, tank 2 for SE 2) exceeds the adjusted value **DTSE** and the subordinate tank has not reached its maximum temperature.

Parallel loading will stop as soon as the temperature difference between the collector and the priority tank falls 4 °Ra [2 K] below **DTSE** or the subordinate tank reaches its maximum temperature.

If **priority Su 1** or **Su 2** is adjusted, the tanks are loaded successively. The subordinate tank will only be loaded if the priority tank (tank 1 for Su 1, tank 2 for Su 2) has reached its adjusted maximum temperature (**S1MX** or **S2MX**).

If **priority 0** is adjusted and the switch-on conditions are fulfilled for both tanks, the tanks are loaded in parallel (Arr 6), resp. in an oscillating loading (Arr 4, 5) beginning with the tank with the lowest temperature. In an oscillating loading, solar loading will switch from one tank to the other in steps of 10 °Ra [5 K] temperature difference between the tanks.

If **priority 1 / 2** is adjusted, tank sequence control will be activated (see below) with the corresponding tank as priority tank.

Tank sequence control will be activated when **PRIO** is set to SE 1, SE 2, 1 or 2.

If the priority tank cannot be loaded, the subordinate tank is checked. If useful heat can be added, it will be loaded for the "loading runtime time" (**tRUN** - factory setting 15 min.) After this, the loading process stops and the controller monitors the increase in collector temperature during the loading break time **tLB**. If it increases by 4° Ra [2 K], the break time timer starts again to allow the collector to gain more heat. If the collector temperature does not increase sufficiently, the subordinate tank will be loaded again for the **tRUN** time as before.

As soon as the switch-on condition of the priority tank is fulfilled, it will be loaded. If the switch-on condition of the priority tank is not fulfilled, loading of the second tank will be continued. If the priority tank reaches its maximum temperature, sequence controlled loading will not be carried out.

If tank sequence control is active and the system switches to load the priority tank, the parameter **tLB** also acts as a stabilization timer; during which the switch-off condition **DTF** is ignored while the system operation stabilizes.

**Evacuated tube collector function**

**OTC:**

Evacuated tube collector function  
Adjustment range: OFF/ON  
Factory setting: OFF



This function helps overcome the disadvantages caused by the non-ideal sensor position with some tube collectors.

This function operates within an adjusted time frame (beginning at **TCST** and ending at **TCEN**). It activates the collector circuit pump for an adjustable runtime (**TCRU**) between adjustable standstill intervals (**TCIN**) in order to compensate for the delayed temperature measurement.

**TCST:**

Tube collector function starting time  
Adjustment range: 00:00 ...23:45  
in steps of 00:15  
Factory setting: 07:00



If the runtime **TCRU** is set to more than ten seconds, the pump will be run at 100 % for the first ten seconds of the runtime. For the remaining runtime, the pump will be run at the adjusted minimum speed **nMN**.

If the collector sensor is defective or the collector is blocked, this function is suppressed or switched off.

**TCEN:**

Tube collector function ending time  
Adjustment range: 00:00 ...23:45  
in steps of 00:15  
Factory setting: 19:00



In system layout 7 (Arr = 7) both collectors are operated independently from each other by means of this function. If the tank is being loaded by one collector, the other one is nevertheless operated after the adjusted standstill time.

**TCRU:**

Tube collector function runtime  
Adjustment range: 5 ... 500 s  
in steps of 5 s  
Factory setting: 30 s



**Note:**

If the drainback option **ODB** is activated, **TCRU** will not be available. In that case, the runtime is determined by the parameters **tFLL** and **tSTB**.

**TCIN:**

Tube collector function standstill interval  
Adjustment range: 1 ... 60 min  
in steps of 1 min  
Factory setting: 30 min



**Energy metering**

**OHQM:** Energy metering  
Adjustment range: OFF/ON  
Factory setting: OFF

If **OHQM** is activated, the heat quantity gained can be calculated and displayed. Energy metering is possible on Arr. 1, 3, 4, 5 and 10 if a flowmeter is used. To enable energy metering, proceed as follows:

- ➔ Read the flow rate (l/min) from the flowmeter at maximum pump speed and adjust it in the **FMAX** channel
- ➔ Adjust the heat transfer fluid and the concentration of the antifreeze in the channels **MEDT** and **MED%**.

**FMAX:** Flow rate in l/min  
Adjustment range: 0.5 ... 100.0  
in steps of 0.5  
Factory setting: 6.0

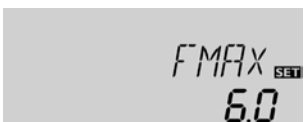

**Heat transfer fluid:**

- 0 : Water
- 1 : Propylene glycol
- 2 : Ethylene glycol
- 3 : Tyfocor® LS / G-LS

**MEDT:** Heat transfer fluid  
Adjustment range: 0...3  
Factory setting: 1



**MED%:** Antifreeze ratio in Vol-% (MED% is hidden when MEDT 0 or 3 is used.)  
Adjustment range: 20 ...70  
in steps of 1 %  
Factory setting: 45



**Note:**

If the system layout 10 has been selected and **OHQM** is activated, energy metering will be interrupted when the 3-way-valve switches to the heat dump.

**Drainback option**



**Note:**  
A drainback system layout requires additional components such as a holding tank. The drainback option should only be activated if all components required are properly installed.



**Note:**  
The drainback option is only available in system layouts with one tank and one collector (Arr 1, 2, 3, 8 and 9).

**ODB:**

Drainback option  
Adjustment range: OFF/ON  
Factory setting: OFF



**Note:**  
When the drainback option **ODB** is activated, the cooling functions **OCC**, **OSYC** and **OSTC** as well as the antifreeze function **OCF** are not available.

If **OCC**, **OSYC**, **OSTC** or **OCF** have already been activated before, they will be deactivated again as soon as **ODB** is activated. They will remain deactivated, even if **ODB** is deactivated later on.

**Time period - switch-on conditions**

**tD<sub>TO</sub>:**

Time period - switch-on conditions  
Adjustment range: 1 ... 100 s in steps of 1 s  
Factory setting: 60 s

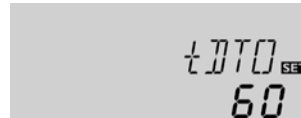

**Filling time**

**tF<sub>LL</sub>:**

Filling time  
Adjustment range: 1.0 ... 30.0 min in steps of 0.5 min  
Factory setting: 5.0 min

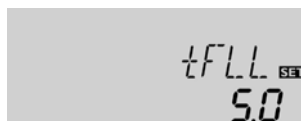

**Stabilization**

**tS<sub>TB</sub>:**

Stabilization  
Adjustment range: 1.0 ... 15.0 min in steps of 0.5 min  
Factory setting: 2.0 min

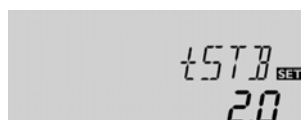

**Booster function option**

**OB<sub>ST</sub>:**

Booster function  
Adjustment range: ON / OFF  
Factory setting: OFF

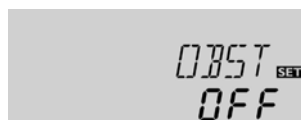

A drainback system permits the heat transfer fluid to drain back into the holding tank when solar energy is not collected. The drainback option will initiate the filling of the system when solar loading begins.

If the drainback option **ODB** is activated, the pump will operate at 100 % speed for the adjusted filling time **tF<sub>LL</sub>** in order to fill the system with fluid from the holding tank. After **tF<sub>LL</sub>**, pump speed will go down to the adjusted minimum pump speed **nMn**. The switch-off conditions will then be ignored for the stabilization time **tS<sub>TB</sub>** in order to avoid the system from shutting down prematurely.

If the function is activated, the menu items described in the following (**tD<sub>TO</sub>**, **tF<sub>LL</sub>** and **tS<sub>TB</sub>**) have to be adjusted:



**Note:**

When the drainback option **ODB** is activated, the temperature differences **DT<sub>O</sub>**, **DT<sub>F</sub>** and **DT<sub>S</sub>** are set to a fixed adjustment. Additionally, the adjustment range and the factory setting of the collector emergency shutdown temperature **EM** changes (see the corresponding channel descriptions for further information).

Previous adjustments made in these channels will be overridden and have to be entered again if **ODB** is deactivated later on.

The parameter **tD<sub>TO</sub>** is used for adjusting the time period during which the switch-on condition **DT<sub>O</sub>** must be permanently fulfilled.

The filling time can be adjusted using the parameter **tF<sub>LL</sub>**. During this period, the pump runs at 100 % speed.

The parameter **tS<sub>TB</sub>** is used for adjusting the time period during which the switch-off condition **DT<sub>F</sub>** will be ignored after the filling time has ended.

This function is used for switching on a second pump when filling the solar system. When solar loading starts, R2 is energized in parallel to R1. After the filling time (**tF<sub>LL</sub>**) has ended, R2 is switched off.



**Note:**

The booster function is available in system layout 1 (Arr = 1) only.

The booster function will only be available if the drainback option has been activated.

**Operating mode**

**MAN1 / MAN2:**

Operating mode  
Adjustment range:  
OFF, Auto, ON  
Factory setting: Auto



For control and service work, the operating mode of the controller can be manually adjusted. For this purpose, select the adjustment value **MAN1, MAN2** in which the following adjustments can be made:

• **MAN1 / MAN2**

Operating mode

- OFF : relay off ⚠ (flashing) + 🖱
- Auto : relay in automatic operation
- ON : relay on ⚠ (flashing) + 🖱



**Note:**

Always adjust the operating mode back to “Auto” when the control and service work is completed. Normal operation is not possible in manual mode.

**Language**

**LANG:**

Language selection  
Selection: dE, En  
Factory setting: En



The menu language can be adjusted in this channel.

- dE : German
- En : English

**Unit**

**UNIT:**

Temperature unit selection  
Selection: °F, °C  
Factory setting: °C



In this adjustment channel, the display unit for temperatures and temperature differences can be chosen. The unit can be switched between °C / K and °F / °Ra during operation. Temperatures and temperature differences in °F and °Ra are displayed without units. If the indication is set to °C, the units are displayed with the values.

**Reset**

**RESE**

Reset function



By using the reset function, all adjustments will be set back to the factory settings.

➔ To initiate a reset, press button 3

Any previous adjustments will be lost. Therefore, initiating the reset function is always followed by a security enquiry.

**Only confirm the security enquiry if you are sure that you wish to reset all adjustments to the factory settings!**

➔ To confirm the security enquiry, press button 3

**Security enquiry:**

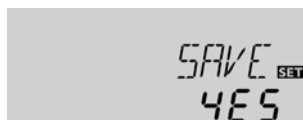

**Note:**

Whenever a reset has been completed, the controller runs the commissioning menu again (see chap. 3).

## 5. Troubleshooting

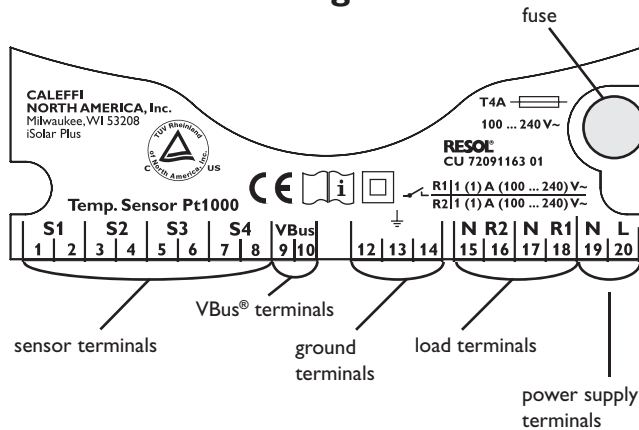

In the case of an error, a message is shown on the display of the controller:

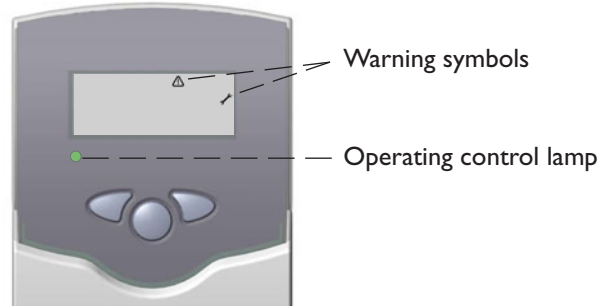

Operating control lamp flashes red. On the display the symbols and appear.

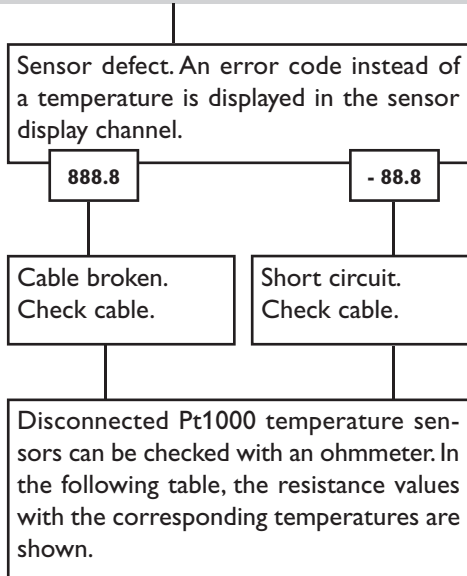

°C	°F	Ω	°C	°F	Ω
-10	14	961	55	131	1213
-5	23	980	60	140	1232
0	32	1000	65	149	1252
5	41	1019	70	158	1271
10	50	1039	75	167	1290
15	59	1058	80	176	1309
20	68	1078	85	185	1328
25	77	1097	90	194	1347
30	86	1117	95	203	1366
35	95	1136	100	212	1385
40	104	1155	105	221	1404
45	113	1175	110	230	1423
50	122	1194	115	239	1442

Resistance values of the Pt1000-sensors

Operating control lamp off.

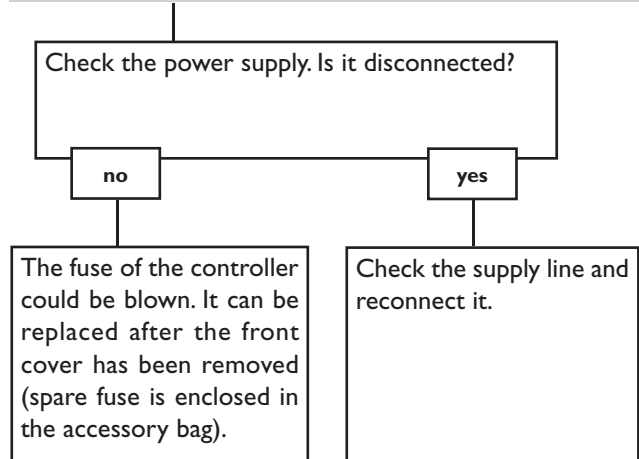

5.1 Various:

Pump is overheated, but no heat transfer from the collector to the tank, flow and return have the same temperature; perhaps also air / gas bubbles in the lines.

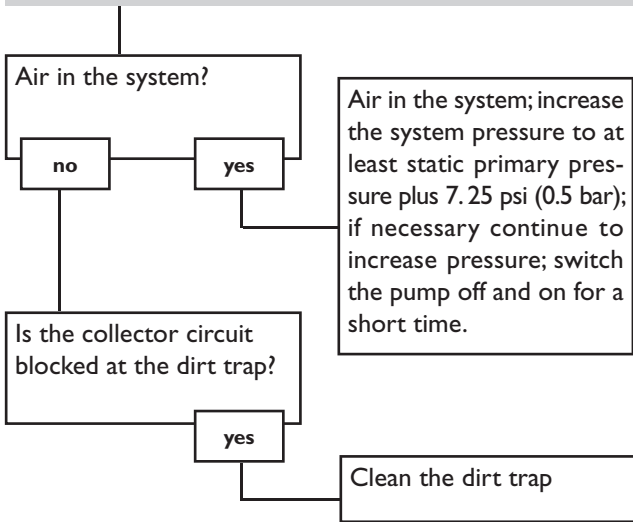

Pump starts for a short moment, switches off, switches on again, etc.

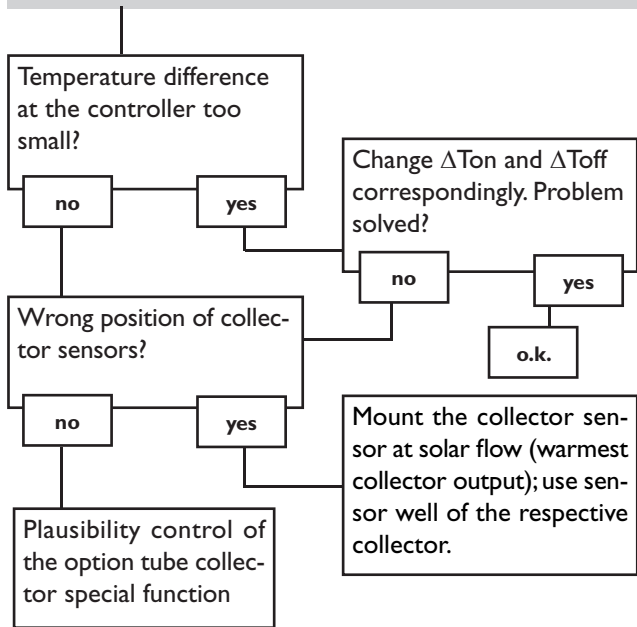

Pump starts up very late

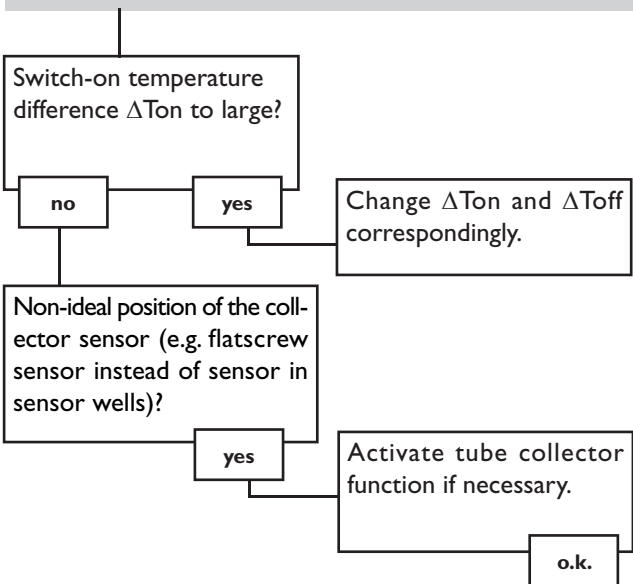

The temperature difference between tank and collector increases enormously during operation; the collector circuit cannot dissipate the heat.

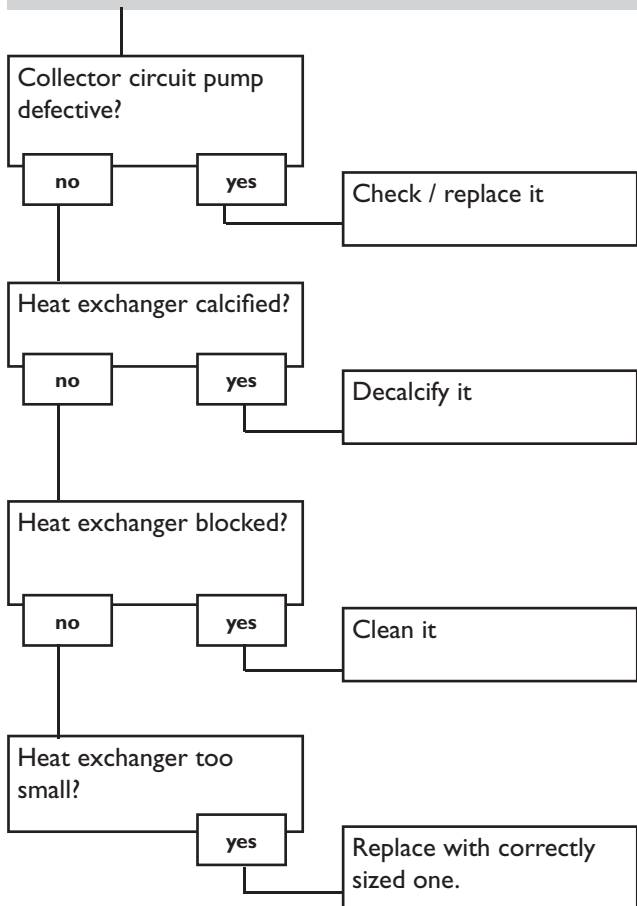

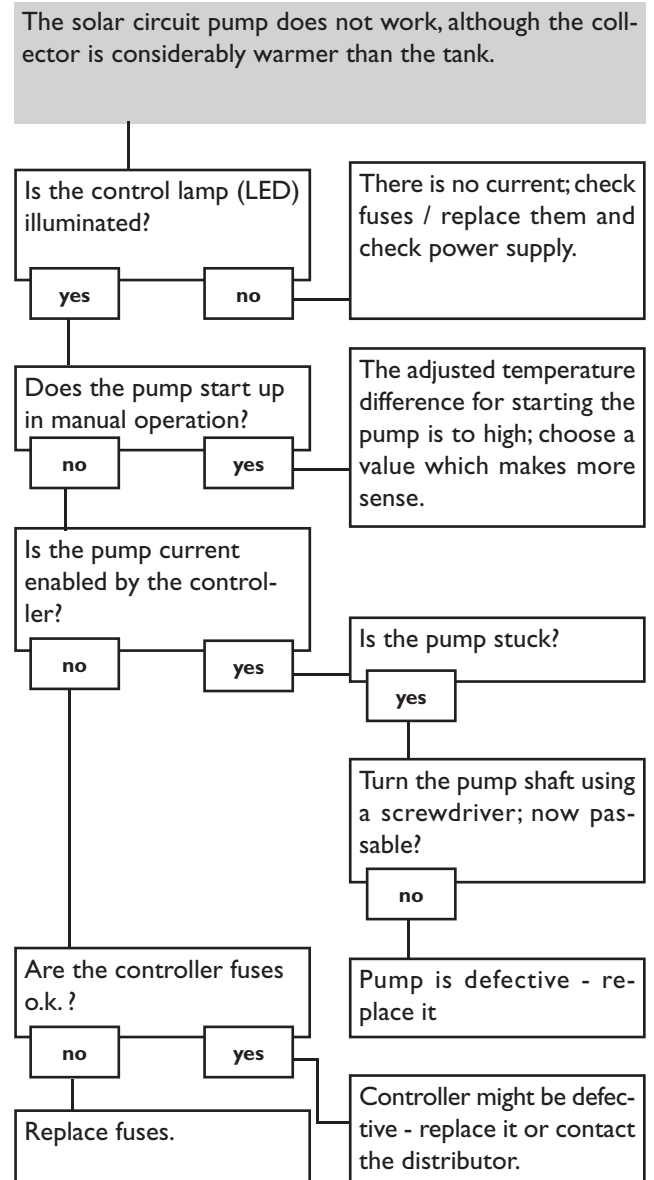
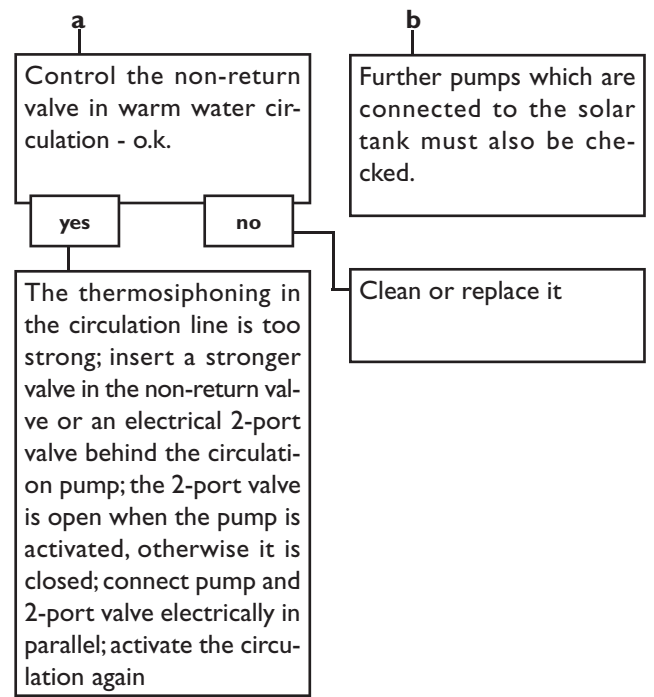
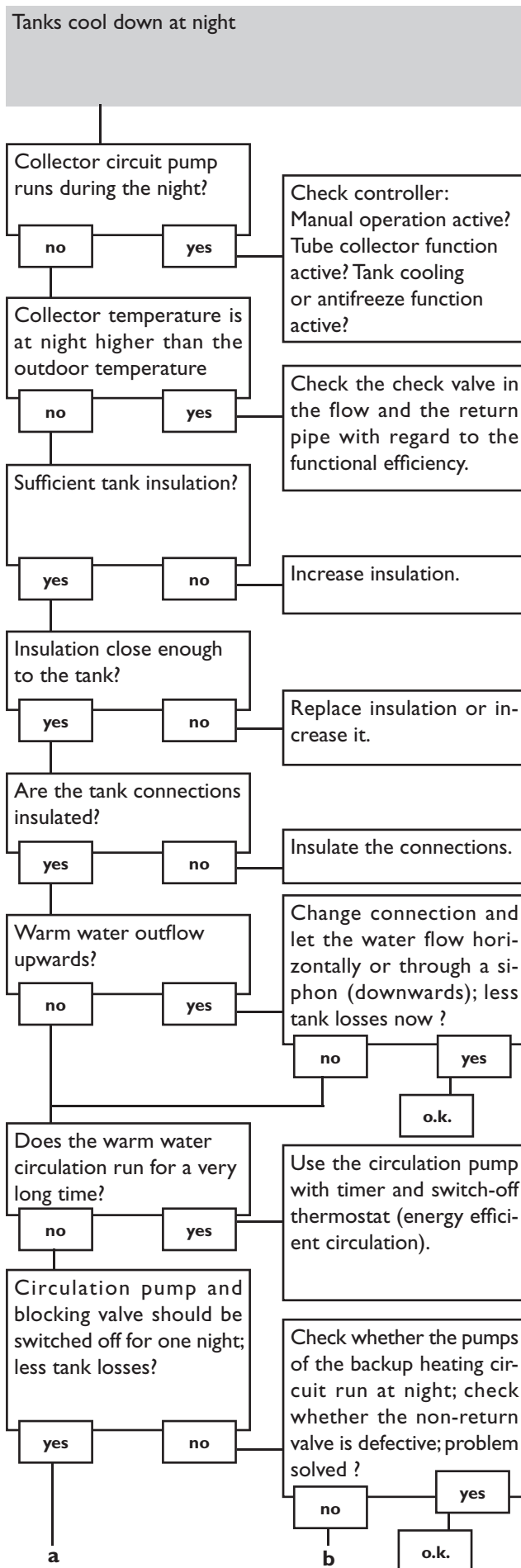

## 6. Accessories

### Sensors

Our product range includes high-precision platinum temperature sensors, flatscrew sensors, outdoor temperature sensors, indoor temperature sensors, cylindrical clip-on sensors, also as complete sensors with immersion sleeve.

For more information, see our catalogue and price list.



### Overvoltage protection device

In order to avoid overvoltage damage at collector sensors (e.g. caused by local lightning storms), we recommend the overvoltage protection SP10.



### Smart Display SD3

The Smart Display is designed for simple connection to controllers with VBus®. It is used for visualizing data issued by the controller: collector temperature, storage temperature and energy yield of the solar thermal system. The use of high-efficient LEDs and filter glass assures a high optical brilliance and good readability even in poor visibility conditions and from a larger distance. An additional power supply is not required.



### Large Display GA3

The Large Display GA3 is designed for simple connection to controllers via the VBus®. It is used for visualizing the data issued by the controller: collector and store temperature as well as heat quantity produced in the solar system.

The use of high-efficient LEDs and antireflective filter glass assures a high optical brilliance and good readability - even in poor lighting conditions and at a larger distance.



### DL2 Datalogger

This additional module enables the acquisition and storage of large amounts of data (such as measuring and balance values of the solar system) over a long period of time. The DL2 can be configured and read-out with a standard internet browser via its integrated web interface. For transmission of the data stored in the internal memory of the DL2 to a PC, an SD card can be used.

The DL2 is appropriate for all controllers with VBus®. It can be connected directly to a PC or router for remote access and thus enables comfortable system monitoring for yield monitoring or for diagnostics of faults.



### VBus® / USB interface adapter

The new VBus® / USB interface adapter is the interface between the controller and a personal computer. With its standard mini-USB port it enables a fast transmission of system data via the VBus® for processing, visualizing and archiving. A full version of the ServiceCenter software is included.



### VBus® / LAN interface adapter

The VBus® / LAN interface adapter is designed for the direct connection of the controller to a PC network or router. It enables easy access to the controller via the local network of the owner. Thus, controller access and data charting can be effected from every workstation of the network. A full version of the ServiceCenter software is included.



### VBus® / PWM interface adapter

The VBus® / PWM interface adapter is used for the speed control of a pump via a PWM or 0-10V signal. Via the VBus®, the adapter receives information from the controller about the necessary pump speed. The speed is converted into a PWM or direct voltage signal and put out to the corresponding terminals.



### AM1 Alarm module

The AM1 alarm module is designed to signal system failures. It is to be connected to the VBus® of the controller and issues an optical signal via a red LED if a failure has occurred. The AM1 also has a dry contact relay output, which can e. g. be connected to a building management system (BMS). Thus, a collective error message can be issued in the case of a system failure.



**Distributed by:**

**CALEFFI NORTH AMERICA, Inc.**

3883 W. Milwaukee Rd.  
Milwaukee, WI 53208

Tel.: +1 414.238.2360

Fax: +1 414.238.2366

[www.caleffi.us](http://www.caleffi.us)

[sales@caleffi.com](mailto:sales@caleffi.com)

**Important notice:**

The texts and drawings in this manual are correct to the best of our knowledge. As faults can never be excluded, please note: Your own calculations and plans, under consideration of the current standards should only be basis for your projects. We do not offer a guarantee for the completeness of the drawings and texts of this manual - they only represent some examples. They can only be used at your own risk. No liability is assumed for incorrect, incomplete or false information and / or any resulting damages.

**Please note:**

The design and the specifications can be changed without prior notice. The illustrations may differ from the original product.

**Reprinting / copying**

This mounting- and operation manual including all parts is copyrighted. Another use outside the copyright requires the approval of CALEFFI NORTH AMERICA, Inc.. This especially applies for copies, translations, microfilms and the storage into electronic systems.

Editor: CALEFFI NORTH AMERICA, Inc.