

Motorized ball valves with 3-wire control

6442 - 6443 series



Function

Zone valves are used to automatically shut-off the flow, redirect or modulate hot and chilled water in hydronic heating and air conditioning systems.

The motorized three-way diverting / mixing valves permits two position diverting or three-way mixing with 3-wire floating outdoor reset controller for injection mixing.

The motorized three-way bypass valves permits a system to operate with a continuous flow regardless if the zone valve is in the open or in the by-pass position.

The high flow and high close-off performance characteristics of these zone valves, combined with the compact size, makes them particularly suitable to fit inside baseboard or directly in fan coils units.

Motorized ball valves series 644 are used in all types of systems because of the following characteristics:

- Zero leakage across the valve
- Quick opening and closing valve operation
- Operates at very high differential pressures
- Low pressure drop through the valve
- Union connections for simple installs and removals

Patent Pending Number ME2005A001282

Product range

Series 6442	Zone valve 2-way with 24V actuator 3-wire control and auxiliary micro-switch	_____	1/2", 3/4", 1" union sweat or NPT
Series 6443.. 3BY	Zone valve 3-way by-pass with 24V actuator 3-wire control and auxiliary micro-switch	___	1/2", 3/4", 1" union sweat or NPT
Series 6443..	Zone valve 3-way diverting with 24V actuator 3 wire control and auxiliary micro-switch	___	1/2", 3/4", 1" union sweat or NPT

Technical specifications

Valve body

Connections:	1/2" - 3/4" - 1" sweat or NPT
Materials:	- body: brass
	- ball: chrome plated brass
	- ball seal: PTFE with EPDM O-Ring
	- stem seal: two EPDM O-Rings
Medium:	water, glycol solutions
Max percentage of glycol:	50%
Max working pressure:	150 psi (10 bar)
Temperature range:	20–230°F (-5–110°C)
Max pressure differential:	150 psi (10 bar)

Actuator

Materials:	polycarbonate
Synchro motor:	24 VAC (± 10%) - 50/60 Hz
Power requirements:	4 VA
Micro-switch:	5A
Time to rotate 90°:	40 s
Ambient temperature range:	0–55°C
Dynamic starting torque:	70 in·lb (8 N·m)
Wire lead length:	40 in. (1 m)
Temperature range:	32–130°F (0–55°C)

Dimensions

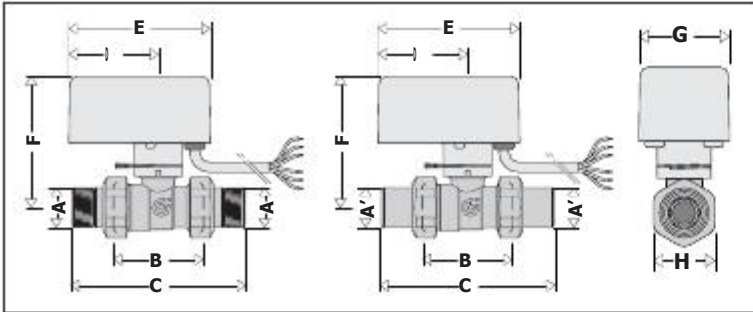

Code	A	B	C	D	E	F	G	H	Weight (lb)
644249A	1/2"	2 3/8"	4 5/8"	2 3/8"	3 3/4"	3 7/16"	2 3/16"	1 7/16"	2.14
644259A	3/4"	2 3/8"	4 5/8"	2 3/8"	3 3/4"	3 7/16"	2 3/16"	1 7/16"	2.14
644269A	1"	2 3/8"	5 1/4"	2 3/8"	3 3/4"	3 7/16"	2 3/16"	1 1/2"	2.20
644240A	1/2" swt	2 3/8"	3 7/8"	2 3/8"	3 3/4"	3 7/16"	2 3/16"	1 7/16"	2.00
644250A	3/4" swt	2 3/8"	4 7/16"	2 3/8"	3 3/4"	3 7/16"	2 3/16"	1 7/16"	2.10
644260A	1" swt	2 3/8"	5 9/16"	2 3/8"	3 3/4"	3 7/16"	2 3/16"	1 1/2"	2.30

**6442 series
2-way**

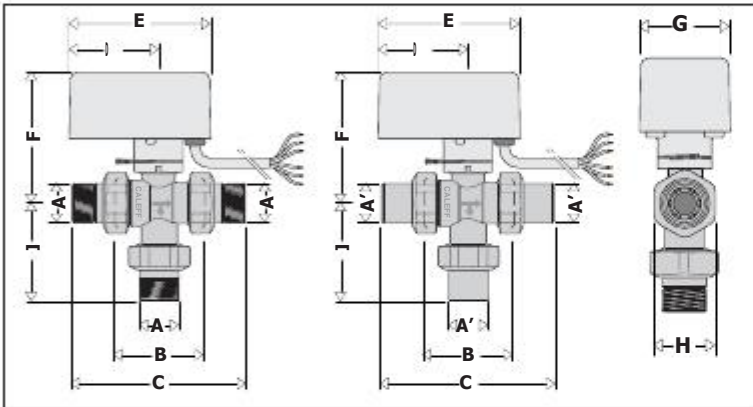
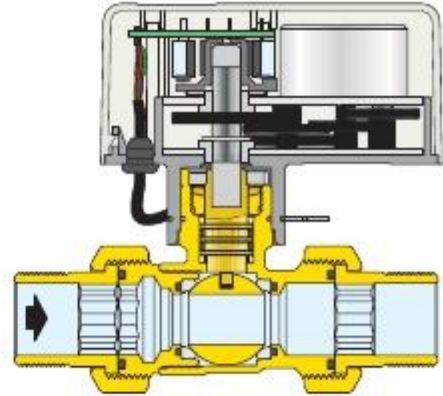

Code	A	B	C	D	E	F	G	H	I	Weight (lb)
644349A 3BY	1/2"	2 3/8"	4 5/8"	2 3/8"	3 3/4"	3 7/16"	2 3/16"	1 7/16"	2 5/16"	2.42
644359A 3BY	3/4"	2 3/8"	4 5/8"	2 3/8"	3 3/4"	3 7/16"	3/16"	1 7/16"	2 5/16"	2.42
644369A 3BY	1"	2 3/8"	5 1/4"	2 3/8"	3 3/4"	3 7/16"	3/16"	1 1/2"	2 5/8"	2.50
644340A 3BY 1/2" swt	2 3/8"	3 7/8"	3 7/8"	2 3/8"	3 3/4"	3 7/16"	3/16"	1 7/16"	1 7/8"	2.31
644350A 3BY 3/4" swt	2 3/8"	4 7/16"	4 7/16"	2 3/8"	3 3/4"	3 7/16"	3/16"	1 7/16"	2 1/8"	2.41
644360A 3BY 1" swt	2 3/8"	5 9/16"	5 9/16"	2 3/8"	3 3/4"	3 7/16"	3/16"	1 1/2"	2 3/4"	2.50

**6443.. 3BY series
3-way by-pass
version**

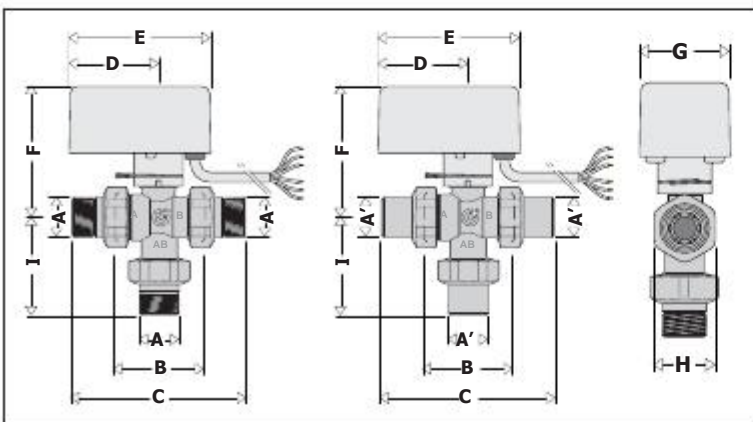
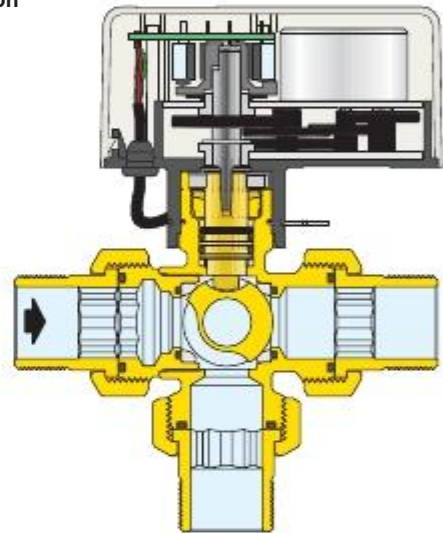

Code	A	B	C	D	E	F	G	H	I	Weight (lb)
644349A	1/2"	2 3/8"	4 5/8"	2 3/8"	3 3/4"	3 7/16"	2 3/16"	1 7/16"	2 5/16"	2.42
644359A	3/4"	2 3/8"	4 5/8"	2 3/8"	3 3/4"	3 7/16"	2 3/16"	1 7/16"	2 5/16"	2.42
644369A	1"	2 3/8"	5 1/4"	2 3/8"	3 3/4"	3 7/16"	2 3/16"	1 1/2"	2 5/8"	2.50
644340A 1/2" swt	2 3/8"	3 7/8"	3 7/8"	2 3/8"	3 3/4"	3 7/16"	2 3/16"	1 7/16"	1 7/8"	2.31
644350A 3/4" swt	2 3/8"	4 7/16"	4 7/16"	2 3/8"	3 3/4"	3 7/16"	2 3/16"	1 7/16"	2 1/8"	2.41
644360A 1" swt	2 3/8"	5 9/16"	5 9/16"	2 3/8"	3 3/4"	3 7/16"	2 3/16"	1 1/2"	2 3/4"	2.50

**3-way 6443.. series,
diverter version**

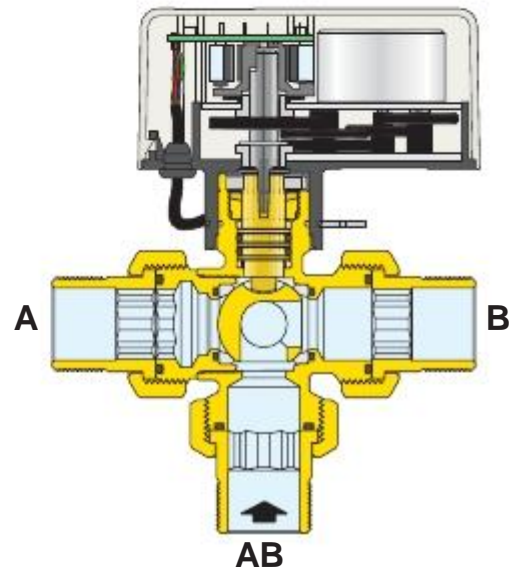

Construction details

Seals

The valves are equipped with unions with a flat seat with EPDM O-Ring seal.

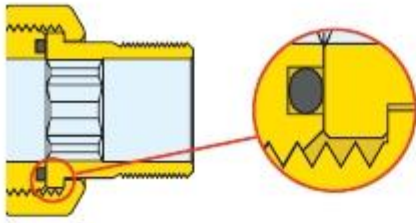

Actuator

• ON/OFF mode

The valves can be used in ON/OFF mode with a single electrical enabling signal for opening or closing given by a three-wire thermostat/timer-thermostat or an ordinary switch.

• Modulating mode

The electrical construction features of the actuator allow it to be combined with any type of three-wire floating controller.

• Drive transmission

Thanks to the tapered coupling between the stem of the valve (A) and the shaft of the gearmotor (B), there is a constant mesh of the two components. This permits automatic compensation of the mechanical slack thanks to the force (C) on the stem applied by the pressure of the medium.

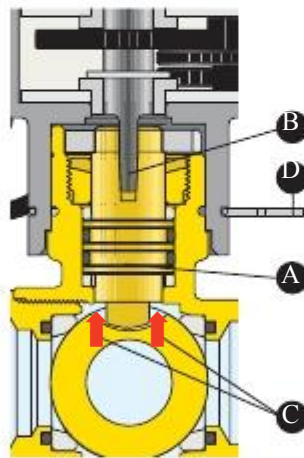

• Valve actuator coupling

By means of a steel clip (D), the coupling between the valve and actuator is fast and easy with a straightforward coupling operation with automatic locking.

• Cam and limit microswitches

The cam (A) that works the limit microswitches (B) can move vertically and is supported by a tapered spring (C). In this way the contact with the microswitches is kept constant compensating for wear of the parts over time.

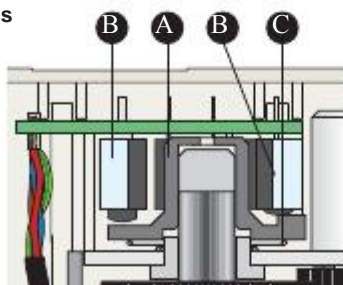

• Auxiliary microswitch

The actuator is equipped with an auxiliary microswitch to be used, for instance, to stop the pump on closing the valve and vice versa. It turns on for an average valve opening value of 80%.

Directions of flow and position indicator

Removing the actuator reveals the slot on the top of the control stem on which acts the pin of the actuator:

- it permits opening/closing the valve manually with a screwdriver.
- its position shows the direction of flow according to the position of the ball, which is especially helpful when testing or checking the system. Here are three diagrams, one for each type of valve; the position of the slot shows the direction of flow.

Two-way valve 6442 series

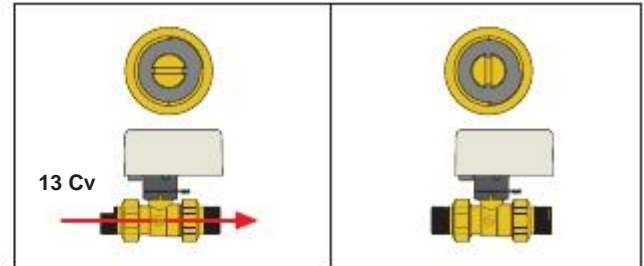

Three-way valve with by-pass 6443.. 3BY series

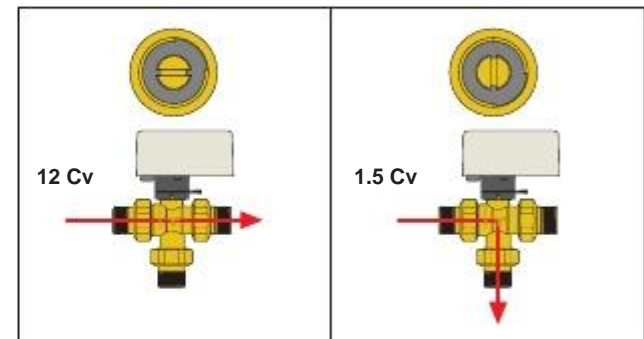

Three-way diverter valve 6443 series

Flow diversion can be modulating with the electrical characteristics of the three-wire control actuator.

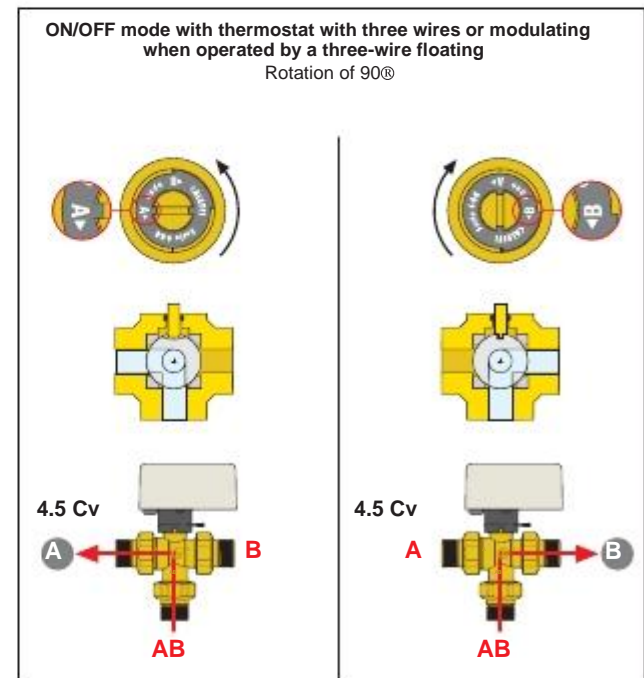

All the valves are supplied with the slot/indicator in the horizontal position.

Hydraulic characteristics

Two-way zone valve 6442 series, sizes 1/2", 3/4" and 1"

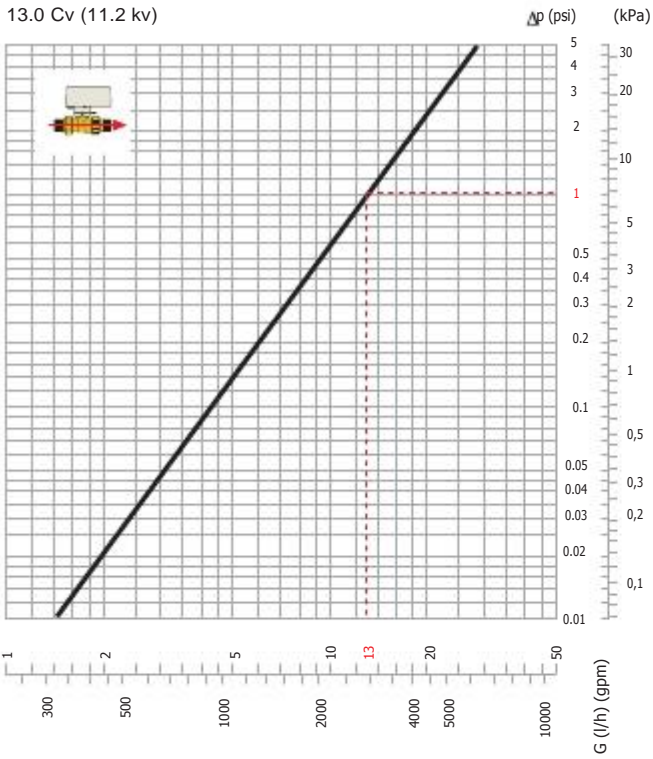

Three-way zone valve with by-pass series 6443.. 3BY on "by-pass" operation, sizes 1/2", 3/4", 1"

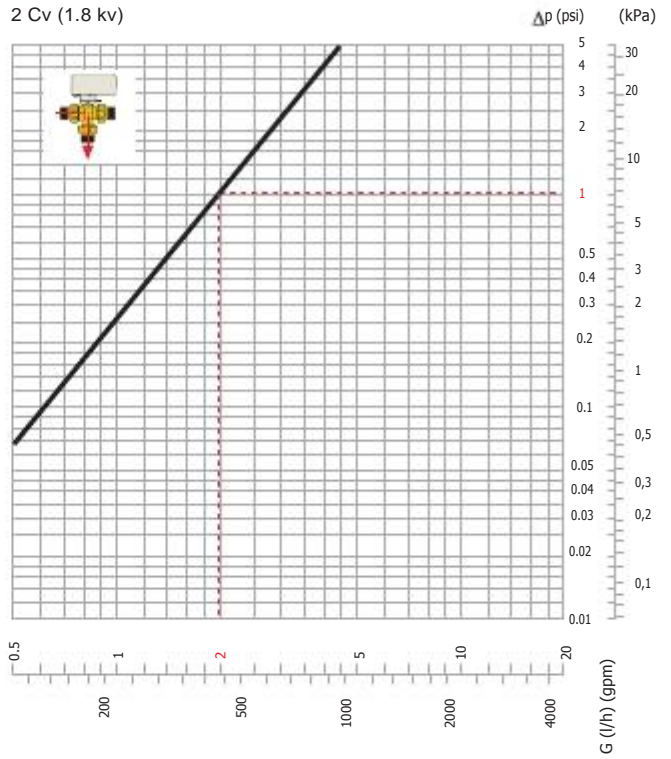

Three-way zone valve with by-pass series 6443.. 3BY on "open" operation, sizes 1/2", 3/4", 1"

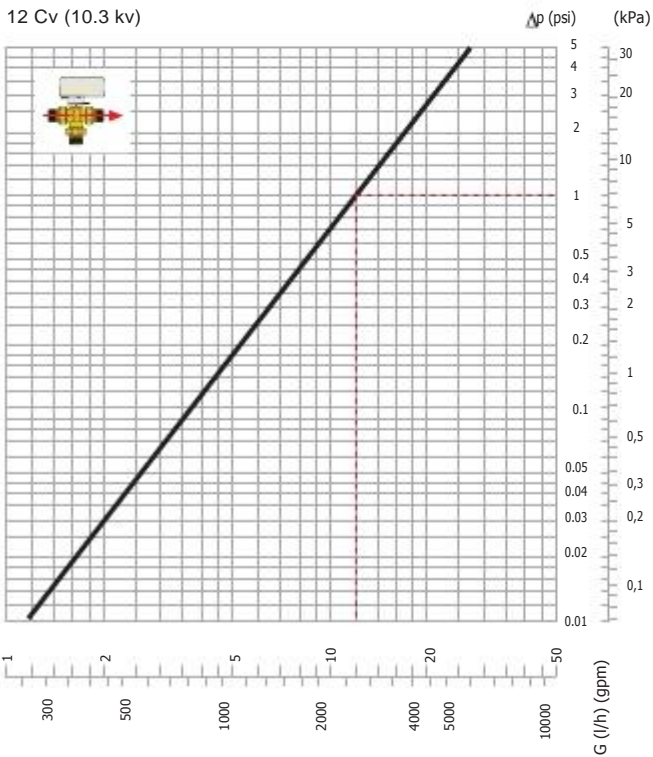

Three-way diverter valve 6443.. series, sizes 1/2" and 3/4"

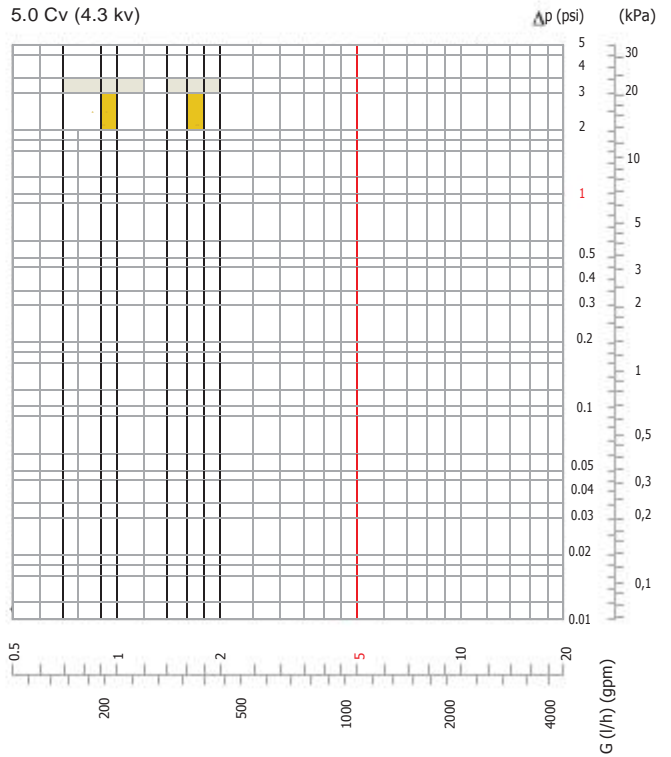

Installation

1. The two-way valve can be installed either on the flow pipe or on the return pipe.

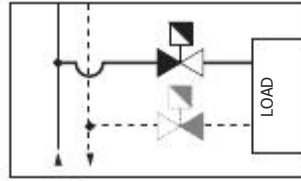

2. The three-way valves with by-pass must be installed on the flow pipe.

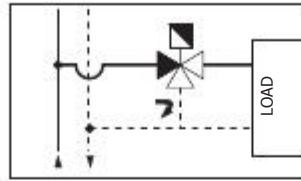

3. The three-way **diverter** valves can be installed as shown:

- a. on the flow in the diverter /mixer position (common inlet AB and outlets A or B) and ON/OFF mode

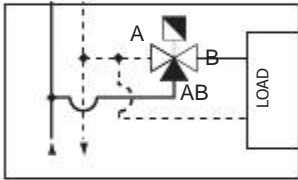

- b. on the return in the mixer position (that is inlets on A and B and common outlet AB) and ON/OFF mode

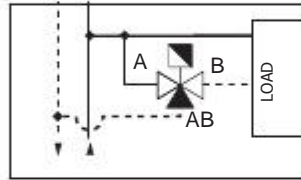

4. The valve must be installed with the control stem in the horizontal or vertical position, **never overturned**.

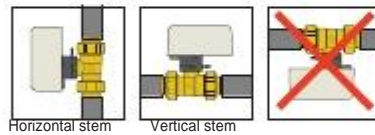

- 4b. In installations with chilled water, with the risk of condensation, the actuator must be installed with the control stem vertical.

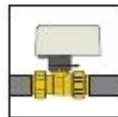

5. The actuator can be fitted on the valve body in the two positions shown. Fastening is with a stainless steel clip.

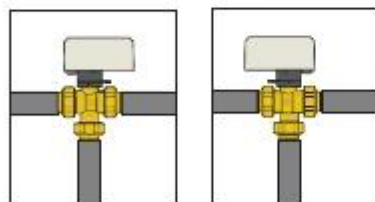

6. In a box installation leave a gap of at least 1 1/4" between the actuator and frame for replacement, if necessary, or maintenance.

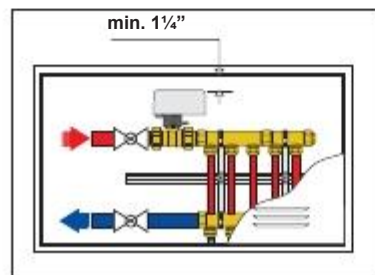

6. To prevent the actuator from reaching high temperatures, where the zone valve is installed there should be constant ventilation.

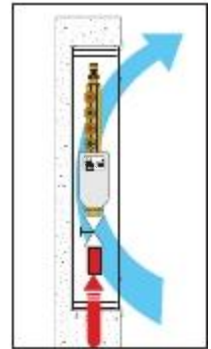

Wiring diagrams

1. **Connection diagram for room thermostat (RT) and electric supply.**

The illustrated connection permits opening and closing the valve according to the ambient thermostat signal.

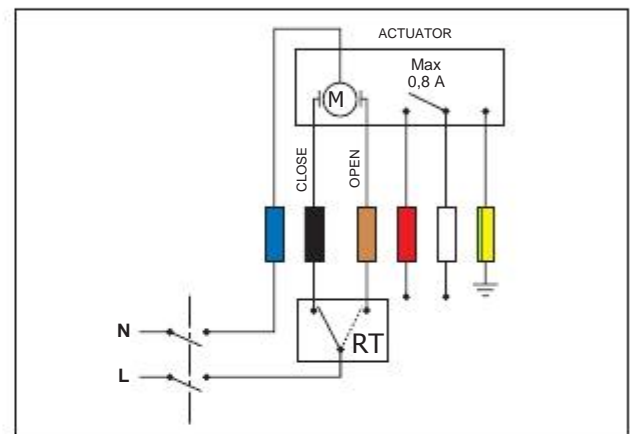

2. **Pump disconnection diagram when no zone is in operation.**

This diagram, using the auxiliary microswitch, permits turning off the pump when the zone valve is closed.

If the pump has an input current greater than 0,8 A (170 VA) it is necessary to use an intermediate relay.

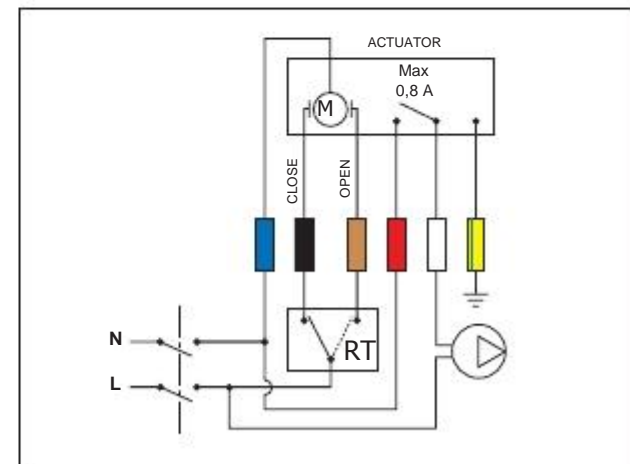

Microswitches

The motor is equipped with limit microswitches that cut off the electricity supply on reaching the valve open/closed positions.

The auxiliary microswitch turns on for an average valve opening value of 80%.

Application diagrams

In systems with zone control, action is taken to automatically cut off the circuits serving the heat exchanger terminal emitters, according to the temperature reached in the room. This circuit closing can however cause changes in pressure and flow rate throughout the system so it is essential to make sure these changes are kept under control within acceptable limits.

System with 6442 series two-way zone valves, differential by-pass valve

The system works with variable flow rate and it is necessary to keep the pressure differential generated by the zone valves closing under control. This increase, which can reach unacceptable limits for the system to work properly, translates into an increase in the flow rate to the circuits still open, with problems for the pumps and the boiler. It is therefore necessary to keep the pressure differentials under control by means of differential by-pass valves or variable speed pumps.

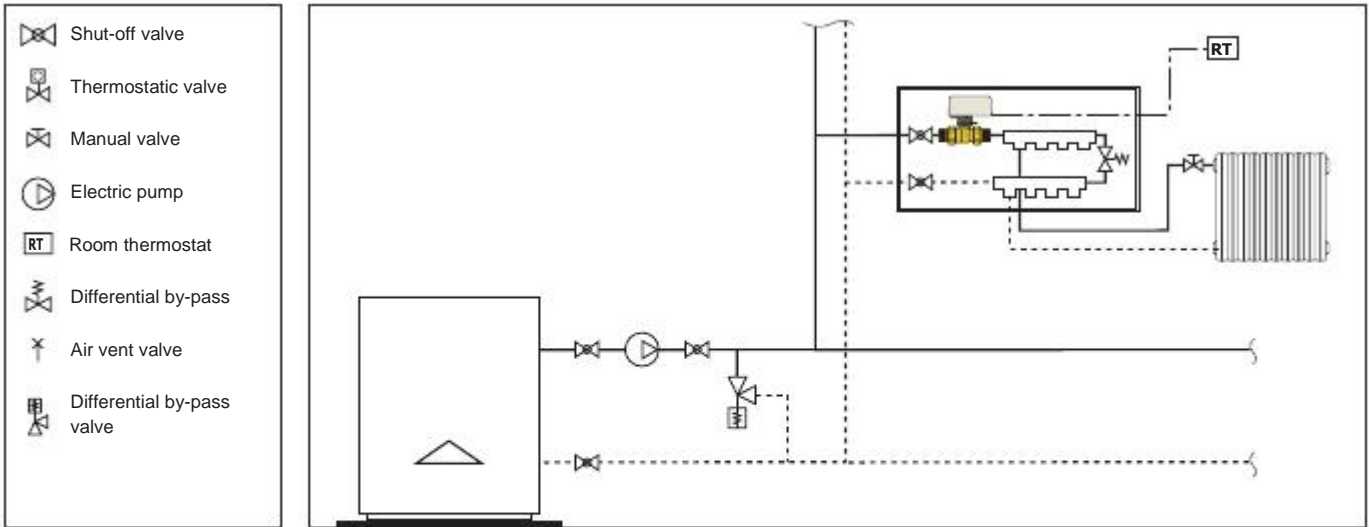

System with code 6443.. 3BY three-way zone valve with by-pass

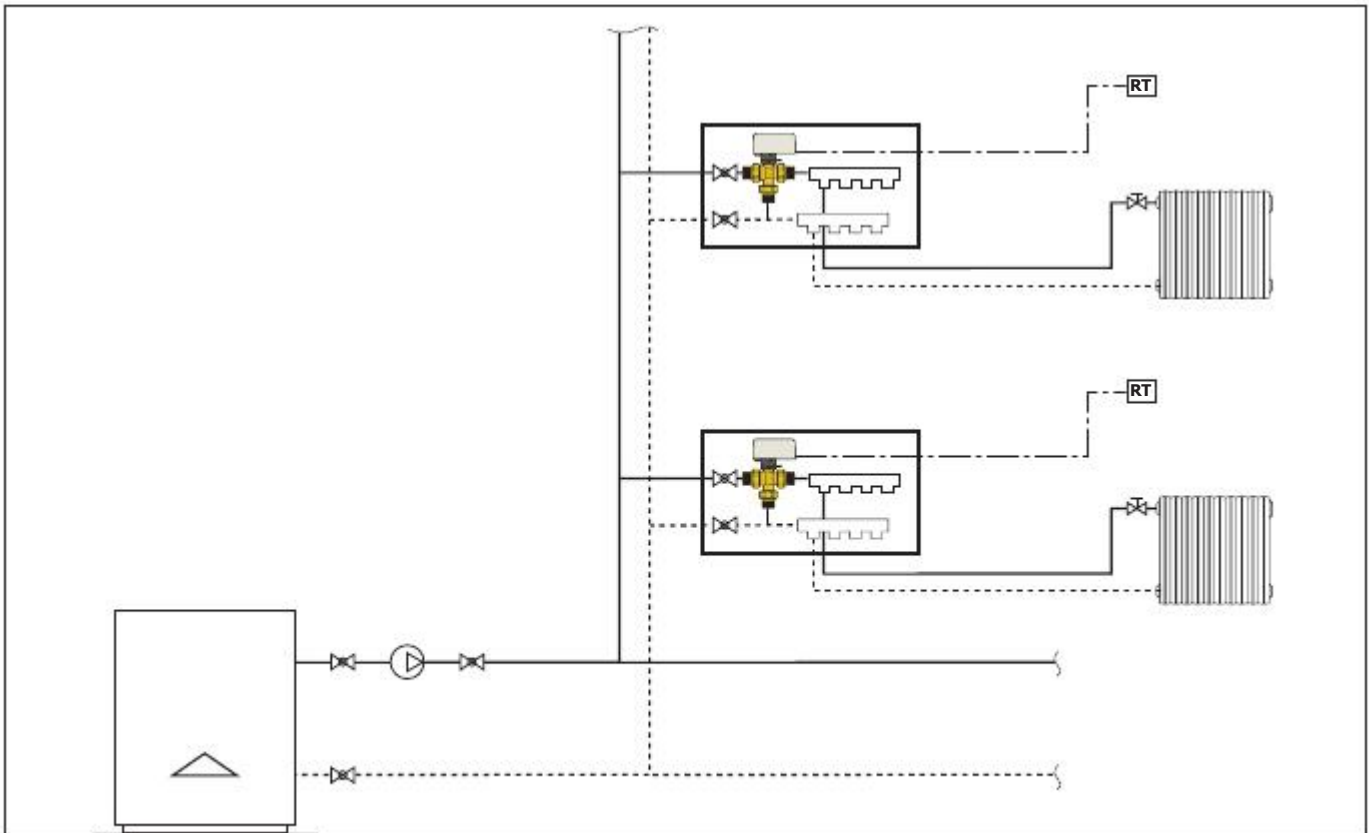

Solar heating system with three-way diverter valve

If the water from the storage tank is at a lower temperature than as required (and set on the thermostat) the diverter valve sends the water to the water heater. Otherwise, the valve sends the water to the mixer directly.

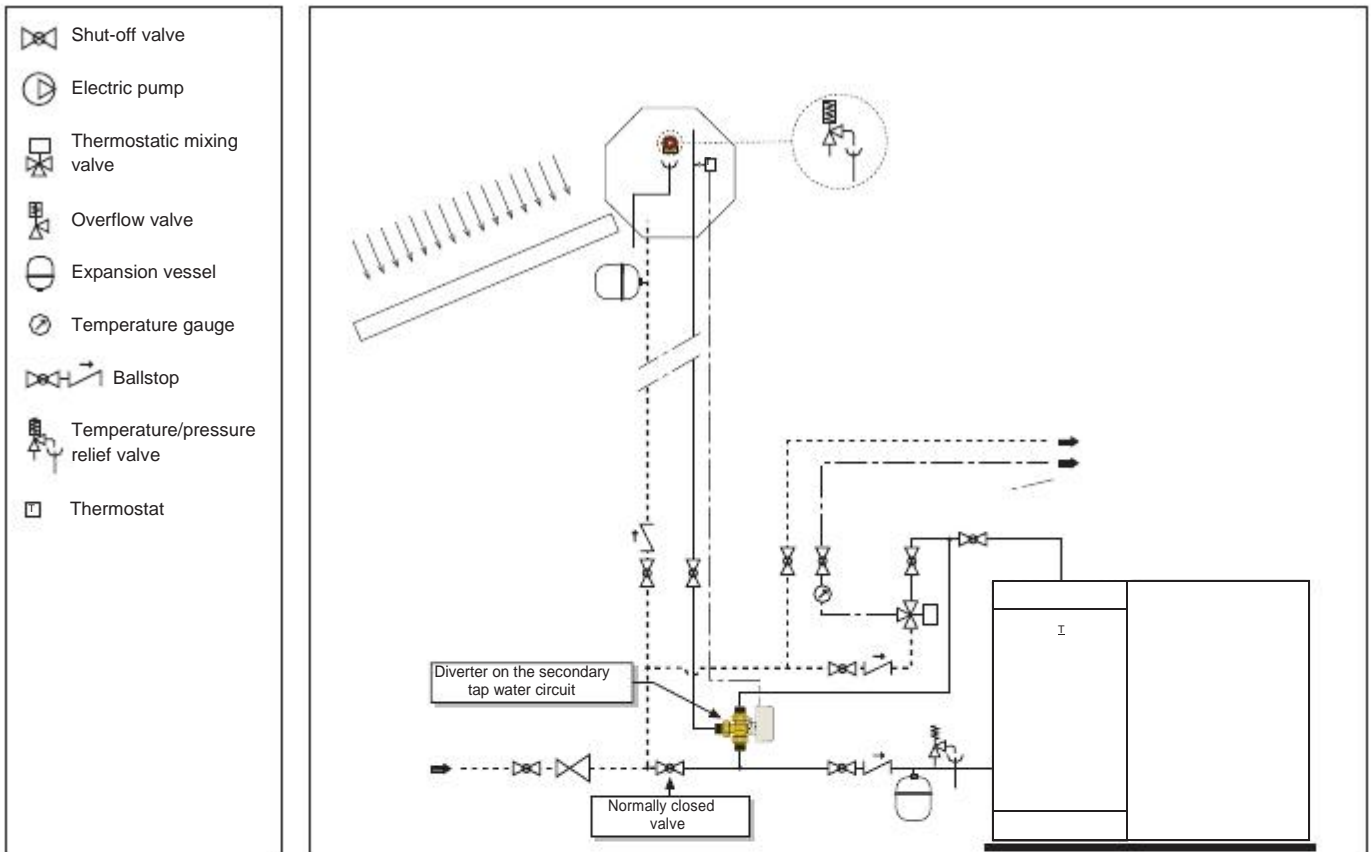

Hot water production system with storage

The water heated by the boiler is sent by priority to the storage via the diverter valve to keep the temperature of the hot tap water. When the storage reaches the set temperature, the water is diverted to the heating circuit.

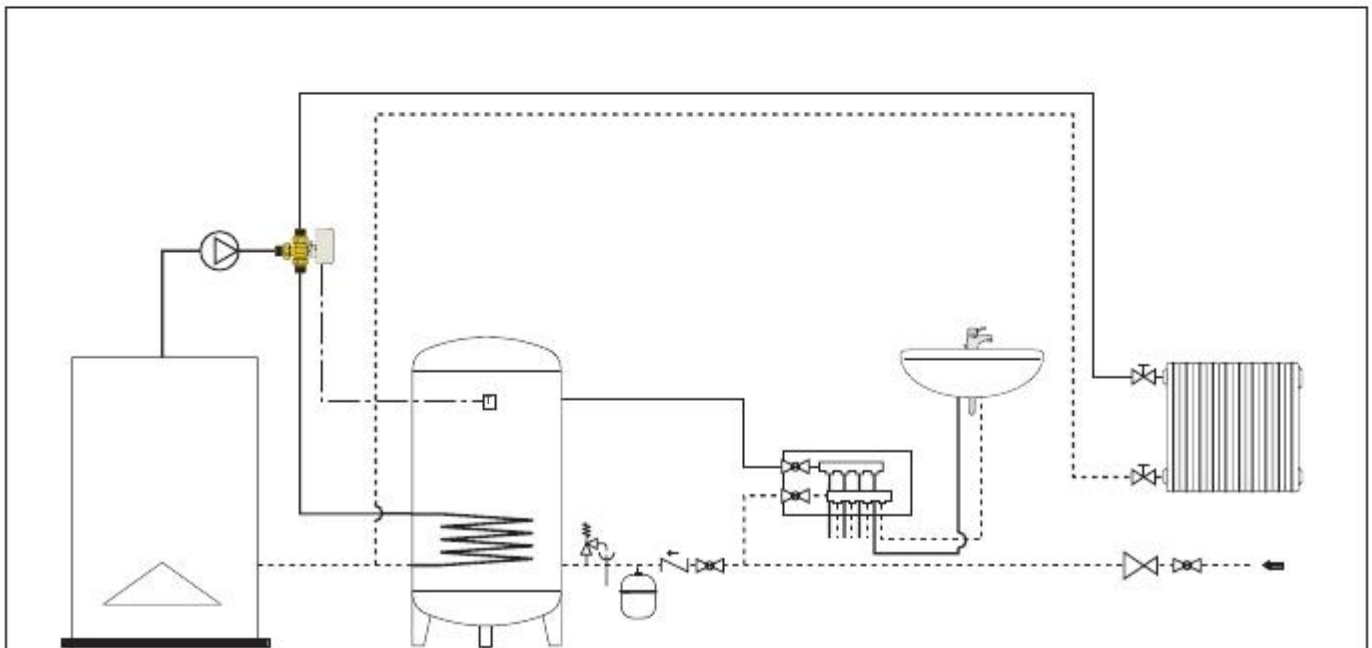

SPECIFICATION SUMMARIES

6442 series

Motorized two-way ball zone valve with three-wire control. 1/2" (from 1/2" to 1") union sweat or NPT. Brass body. Chrome plated brass ball. Ball seal made of PTFE with O-Ring in EPDM. Control stem seal with double O-Ring in EPDM. Union seals with O-Ring in EPDM. Medium water and glycol solutions. Maximum percentage of glycol 50%. Maximum working pressure 145 psi (10 bar). Temperature range 20–230°F (-5–110 °C). Maximum working differential pressure 150 psi (10 bar). Self-extinguishing polycarbonate actuator; grey RAL 9002; synchronous three-wire motor with auxiliary microswitch; electric supply 24 V; power consumption 4 VA; dynamic starting torque 70 in-lb (8 N·m). Auxiliary microswitch contacts rating 0,8 A. Operating time (angle of rotation 90°C) 40 s; ambient temperature range 32–130°F (0–55°C).

Code 6443.. 3BY

Motorised three-way ball zone valve, by-pass version, with three-wire control. 1/2" (from 1/2" to 1") union sweat or NPT. Brass body. Chrome plated brass ball. Ball seal made of PTFE with O-Ring in EPDM. Control stem seal with double O-Ring in EPDM. Union seals with O-Ring in EPDM. Medium water and glycol solutions. Maximum percentage of glycol 50%. Maximum working pressure 150 psi (10 bar). Temperature range 20–230°F (-5–110 °C). Maximum working differential pressure 150 psi (10 bar). Self-extinguishing polycarbonate actuator; grey RAL 9002; synchronous three-contact motor with auxiliary microswitch; electric supply 24 V; power consumption 4 VA; dynamic starting torque 70 in-lb (8 N·m). Auxiliary microswitch contacts rating 0,8 A. Operating time (angle of rotation 90°C) 40 s; ambient temperature range 32–130°F (0–55°C).

Code 6443..

Motorised diverter/mixer three-way ball valve with three-wire control. 1/2" (1/2", 3/4" and 1") union sweat or NPT. Brass body. Chrome plated brass ball. Ball seal made of PTFE with O-Ring in EPDM. Control stem seal with double O-Ring in EPDM. Union seals with O-Ring in EPDM. Medium water and glycol solutions. Maximum percentage of glycol 50%. Maximum working pressure 150 psi (10 bar). Temperature range 20–230°F (-5–110 °C). Maximum working differential pressure 150 psi (10 bar). Self-extinguishing polycarbonate actuator; grey RAL 9002; synchronous three-contact motor with auxiliary microswitch; electric supply 24 V; power consumption 4 VA; dynamic starting torque 70 in-lb (8 N·m). Auxiliary microswitch contacts rating 0,8 A. Operating time (angle of rotation 90°C) 40 s; ambient temperature range 32–130°F (0–55°C).

We reserve the right to change our products and their relevant technical data, contained in this publication, at any time and without prior notice.



Caleffi North America, Inc.
9850 South 54th Street / Milwaukee, WI 53132
Tel: 414.421.1000 / Fax: 414.421.2878 / www.caleffi.us
© Copyright 2007 Caleffi North America, Inc.