

prestige

PVC & CPVC Vent Supplement



⚠ WARNING

This document is intended to be used by a qualified heating contractor or service technician. Read all instructions within this document and within the PRESTIGE Boiler Installation and Maintenance Manual, before proceeding with the installation. It is recommended to follow the procedures in the steps given, skipping or missing procedural steps could result in severe personal injury, death or substantial property damage.

NOTICE

Installation of this boiler must comply with local requirements and codes and with the National Fuel Gas Code NFPA 54, ANSI Z223.1 for installations within the U.S. For installations in Canada the installation must comply with CSA B149.1 or B149.2

PRODUCT AND SAFETY INFORMATION

Definitions 1
 Installer Information 1
 Homeowner Information 1

SECTION I - PRE-INSTALLATION REQUIREMENTS

Removal of an Existing Boiler from a Common Vent System 2
 Vent/Combustion Air Piping and Materials 3
 Combustion Air Contamination 4

SECTION II - DIRECT VENT INSTALLATION OF VENT/AIR PIPING

Direct Vent - Vertical - Through the Roof or Unused Chimney 5-7
 Direct Vent - Vent Installation - Through the Roof 7-8
 Direct Vent - Multiple Boiler Installation - Through the Roof 9
 Direct Vent - Horizontal - Sidewall 10-13
 Direct Vent - Vent Installation - Sidewall 14-15
 Direct Vent - Multiple Boiler Installation - Sidewall 16
 Direct Vent - Vertical Vent and Sidewall Combustion Air 17-18
 Direct Vent - Vent Installation - Through the Roof 18
 Direct Vent - Combustion Air Installation - Sidewall 18-19
 Direct Vent - Multiple Boiler Installation -
 Vertical Vent and Sidewall Combustion Air 19
 3" To 4" Vent/Combustion Air Transition 20
 Insert Piping to PRESTIGE Adapters 20
 Vent and Combustion Air Piping Installation Guidelines 20-21

SECTION III - CATEGORY IV (INDOOR AIR) INSTALLATION OF VENT/AIR PIPING

Category IV - Vertical - Through the Roof or Unused Chimney 22-23
 Category IV - Vent Installation - Through the Roof 23
 Category IV - Multiple Boiler Installation - Through the Roof 24
 Category IV - Horizontal - Sidewall 24-27
 Category IV - Vent Installation - Sidewall 27
 Category IV - Multiple Boiler Installation - Sidewall 28
 3" To 4" Vent Transition 29
 Insert Piping to PRESTIGE Adapters 29
 Vent and Combustion Air Piping Installation Guidelines 29-30

SECTION IV - COMMONWEALTH OF MASSACHUSETTS

Installation with The Direct Vent
 Termination Elevation at or Below Four Feet of Grade 31
 Installation with The Direct Vent
 Termination Elevation Above Four Feet of Grade 32

DEFINITIONS

The following terms are used throughout this manual to bring attention to the presence of potential hazards or to important information concerning the product.



Indicates the presence of a hazardous situation which, if ignored, will result in death, serious injury or substantial property damage.



Indicates a potentially hazardous situation which, if ignored, can result in death, serious injury or substantial property damage.



Indicates a potentially hazardous situation which, if ignored, may result in minor injury or substantial property damage.

NOTICE

Indicates special instructions on installation, operation or maintenance, which are important to the equipment but not related to personal injury hazards.

BEST PRACTICE

Indicates recommendations made by Triangle Tube for the installers which will help to ensure optimum operation and longevity of the equipment.

INSTALLER



Read all instructions as outlined in this manual and in the boiler installation manual. Failure to comply with these instructions in the order presented could result in personal injury or death.

This document is a supplement to the PRESTIGE boiler installation and maintenance manual. The purpose of this supplement is for the proper installation of the vent and combustion air piping to the boiler.



All PRESTIGE vent and combustion air piping must be installed, terminated and joints sealed as outlined in this manual. Failure to comply with installation procedures outlined in this manual can result in severe personal injury, death or substantial property damage.

NOTICE

Direct Vent and Category IV (Indoor Air) installations using PVC and CPVC materials, for other venting options (materials, terminations, etc.) contact Triangle Tube.

HOMEOWNER

- This manual is intended for use by a qualified heating contractor or service technician.
- Please reference the User Information manual for additional information.
- Ensure this document and all pertaining documents are kept near the boiler to be used by the qualified heating contractor or service technician for future reference.

SECTION I - PRE- INSTALLATION ITEMS

Removal of an Existing Boiler from a Common Vent System



Do not install the PRESTIGE into a common vent with any other gas or oil appliances. This will cause flue gas spillage or appliance malfunction, resulting in possible severe personal injury, death or substantial property damage.

When an existing boiler is removed from a common venting system, the common venting system is likely to be too large for proper venting of the remaining appliances. At the time of removal of an existing boiler, the following steps shall be followed with each appliance remaining connected to the common venting system placed in operation, while the other appliances remaining connected to the common venting system are not in operation.

1. Seal any unused openings in the common venting system.
2. Visually inspect the venting system for proper size and horizontal pitch and determine there is no blockage or restriction, leakage, corrosion and other deficiencies which could cause an unsafe condition.
3. Insofar as is practical close all building doors and windows and all doors between the space in which the appliances remaining connected to the common venting system are located and other spaces of the building. Turn on clothes dryers and any appliance not connected to the common venting system. Turn on any exhaust fans, such as range hoods and bathroom exhausts, so they will operate at maximum speed. Do not operate a summer exhaust fan. Close fireplace dampers.
4. Place in operation the appliance being inspected. Follow the lighting instructions. Adjust thermostat so appliance will operate continuously.

5. Test for spillage at the draft hood relief opening after 5 minutes of main burner operation. Use the flame of a match or candle, or smoke from a cigarette, cigar or pipe.
6. After it has been determined that each appliance remaining connected to the common venting system properly vents when tested as outlined above, return doors, windows, exhaust fans, fireplace dampers and any other gas-burning appliance to their previous condition of use.
7. Any improper operation of the common venting system should be corrected so the installation conforms with the National Fuel Gas Code, ANSI Z223.1/NFPA 54 and/or CAN/CGA B149, Installation Codes. When resizing any portion of the common venting system, the common venting system should be resized to approach the minimum size as determined using the appropriate tables in Part 11 of the National Fuel Gas Code, ANSI Z223.1/NFPA 54 and/or CAN/CGA B149, Installation Codes.



Do not vent the PRESTIGE into a common vent with any other gas or oil burning appliances. This will cause flue gas spillage or appliance malfunction, resulting in possible severe personal injury, death or substantial property damage.

Vent/Combustion Air Piping and Materials

NOTICE

Installation of the vent and combustion air piping must comply with local codes and requirements and with the National Fuel Gas Code NFPA 54, ANSI Z223.1 for installations in the U.S. or with CSA B149.1 or B149.2 for installations in Canada.

The PRESTIGE requires a Category IV venting system which is designed for pressurized venting and condensate.

WARNING

The vent and combustion air materials (piping, fittings and cement) must meet the listed requirements in this manual. Failure to comply with these material requirements could result in severe personal injury, death or substantial property damage.

3" and/or 4" Vent and Combustion Air Piping and Fittings:

- PVC Schedule 40 - ANSI/ASTM D1785
- PVC-DWV - ANSI/ASTM D2665
- CPVC Schedule 40 - ANSI/ASTM F441

Pipe Cement and Primer

- PVC - ANSI/ASTM D2564
- CPVC - ANSI/ASTM F493

NOTICE

For installations in Canada, all piping, fittings and cement/primer material must be certified and listed to ULC-S636.

NOTICE

Do not use cellular core pipe for vent piping. Cellular core pipe may be used for combustion air piping.

WARNING

DO NOT mix vent components from different vent systems. Use only PVC and CPVC pipe and fittings. Seal all pipe and fittings with the appropriate primer and cement. Failure to comply with these requirements could cause venting system failure resulting in leakage of flue products into the living space.

The PRESTIGE is certified per ANSI Z21.13 as a Category IV (indoor air) or Direct Vent (sealed combustion) appliance. A Category IV appliance utilizes uncontaminated indoor or outdoor air (surrounding the appliance) for combustion. A Direct Vent appliance utilizes uncontaminated outdoor air (piped directly to the appliance) for combustion.

BEST PRACTICE

To reduce the potential risks associated with indoor contaminants (listed on page 4), flammable vapors and tight housing construction (little or no infiltration air), it is recommended to pipe uncontaminated combustion air directly from the outdoors to the appliance. This practice also promotes higher system efficiency by reducing heated indoor air from

TABLE 1

PRESTIGE Model	Maximum Allowable Vent or Combustion Air Piping Length				
	3 Inch Piping		OR	4 Inch Piping	
	Feet	Elbows		Feet	Elbows
60	60	0		100	0
110	60	0		100	0
175	60	0		100	0
250	30	0		60	0
399	Not Applicable			100	0
EXCELLENCE	60	0		100	0

Reduce the maximum allowable length for each elbow used as follows:
 - 45° Elbow - Deduct 3 Feet
 - Long or Short Radius 90° Elbow - Deduct 5 Feet

being exhausted from the building and replaced by cold infiltration air.

Combustion Air Contamination



If the PRESTIGE combustion air inlet is located in an area likely to cause or contain contamination, the combustion air must be repiped and terminated at another location. Contaminated combustion air will damage the unit and its burner system, resulting in possible severe personal injury, death or substantial property damage.



Do not operate the PRESTIGE if its combustion air inlet is located near a laundry room or pool facility. These areas will always contain hazardous contaminants.

Pool and laundry products, common household and hobby products often contain fluorine or chlorine compounds. When these chemicals pass through the burner and vent system, they can form strong acids. These acids will corrode the heat exchanger, burner components and vent system, causing serious damage and presenting possible flue gas spillage or water leakage into the surrounding area.

Please read the information listed below. If contaminating chemicals are located near the area of the combustion air inlet, the installer should pipe the combustion air inlet to an outside area free of these chemicals.

Potential contaminating products

- Spray cans containing chloro/fluorocarbons
- Permanent Wave Solutions
- Chlorinated wax
- Chlorine - based swimming pool chemicals / cleaners
- Calcium Chloride used for thawing ice
- Sodium Chloride used for water softening
- Refrigerant leaks
- Paint or varnish removers
- Hydrochloric acid / muriatic acid
- Cements and glues
- Antistatic fabric softeners used in clothe dryers
- Chlorine-type bleaches, detergents, and cleaning solvents found in household laundry rooms
- Adhesives used to fasten building products and other similar products

Areas likely to contain these products

- Dry cleaning / laundry areas and establishments
- Beauty salons
- Metal fabrication shops
- Swimming pools and health spas
- Refrigeration Repair shops
- Photo processing plants
- Auto body shops
- Plastic manufacturing plants
- Furniture refinishing areas and establishments
- New building construction
- Remodeling areas
- Garages with workshops

SECTION II - DIRECT VENT INSTALLATION OF VENT/AIR PIPING

A Direct Vent appliance utilizes uncontaminated outdoor air (piped directly to the appliance) for combustion.

Direct Vent - Vertical - Through the Roof or Unused Chimney

NOTICE

Installation of the vent and combustion air piping must comply with local codes and requirements and with the National Fuel Gas Code NFPA 54, ANSI Z223.1 for installations in the U.S. or CSA B149.1 or B149.2 for installations in Canada.

NOTICE

When using an inoperative chimney as a means of a chase for the vent, the surrounding space within the chimney cannot be used to draw combustion air or vent another appliance.

 **WARNING**

A gas vent extending through a roof should not terminate near an adjacent wall or below any building extensions such as roof eaves, balconies or decks. Failure to comply with the required clearances in this manual could result in severe personal injury, death or substantial property damage.

Determine Termination Location

Locate the vent and combustion air termination using the following guidelines:

1. The total length of the vent or combustion air piping must not exceed the limits given in Table 1 on page 3.

NOTICE

Do not include the two 90° elbows or tee used to terminate the combustion air inlet exterior of the building when determining the total length of pipe.

2. The combustion air piping must terminate in an upside down “U” shape fashion using two 90° elbows as shown in Fig. 1 page 6 or with a tee as shown in Fig. 2 page 6. The termination must be installed 12” [18” Canada] above the highest anticipated snow level.
3. The vent must terminate vertically with a coupling to accept the bird screen and must be located 12” to 24” above the combustion air inlet as shown in Fig. 1 & Fig. 2 on page 6.
4. The vent and combustion air terminations must be located a radial distance of 12” to 24” from centerline of vent termination to centerline of air termination as shown in Figs. 1 & 2 on page 6.
5. The following should be considered when determining the location of the vent and combustion air terminations:
 - a. Locate the vent termination where flue vapors will not damage surrounding shrubs, plants or air conditioning equipment or be objectionable to the homeowner.
 - b. The flue products will form a noticeable plume of water vapor as they condense in colder air. Avoid terminating the vent in areas where the plume could obstruct window views.
 - c. Prevailing winds could cause freezing of flue gas condensation and a buildup of water / ice on surrounding plants, building surfaces or combustion air inlet.
 - d. Avoid locations where prevailing winds could affect the performance of the boiler or cause recirculation of the flue gases, such as inside corners of buildings, near adjacent buildings, vertical surfaces, window wells, stairwells, alcoves, courtyards, or other recessed areas.
 - e. Do not terminate the vent above doors or windows: flue condensate could freeze causing ice formations.

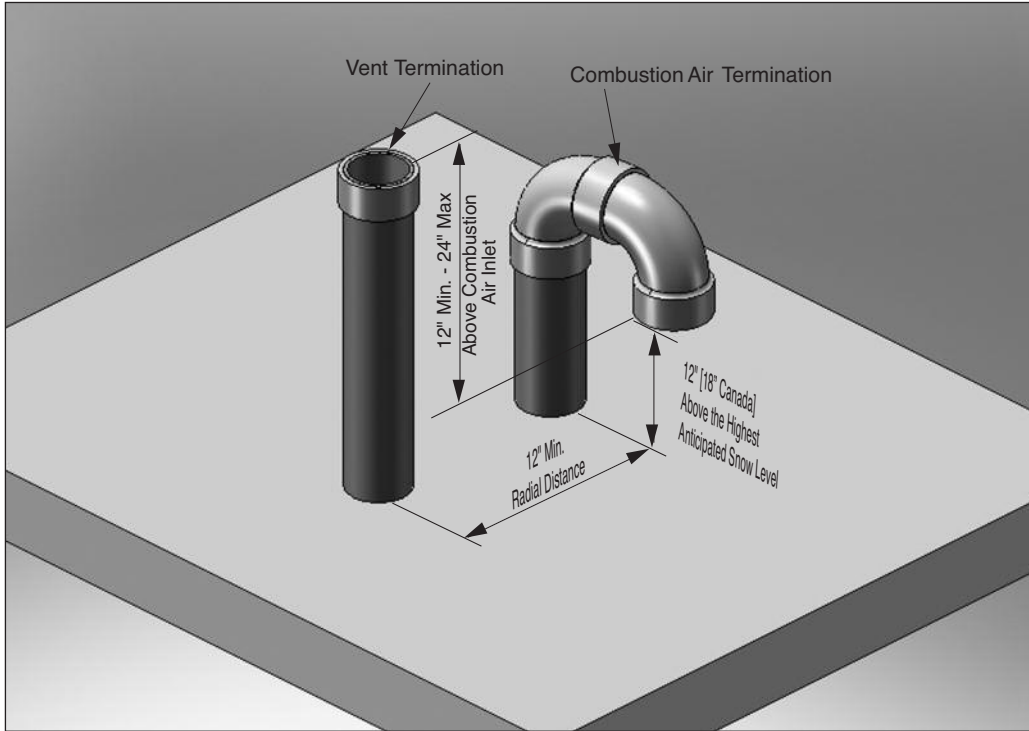

Fig. 1: Direct Vent - Vertical Termination of Vent and Combustion Air Piping.

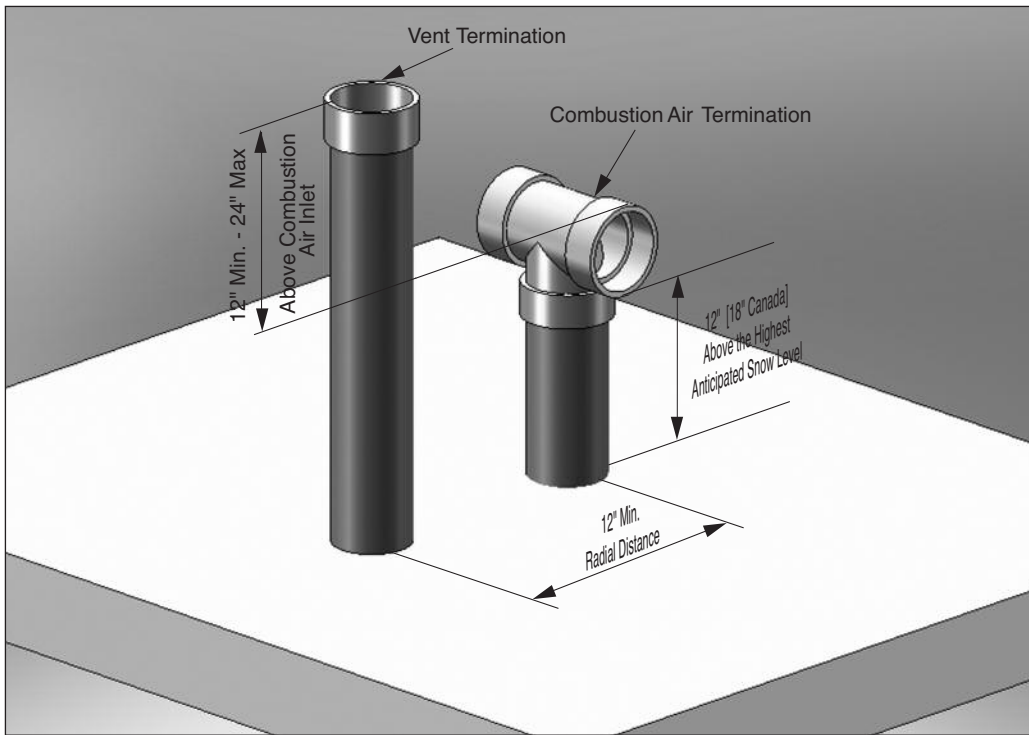
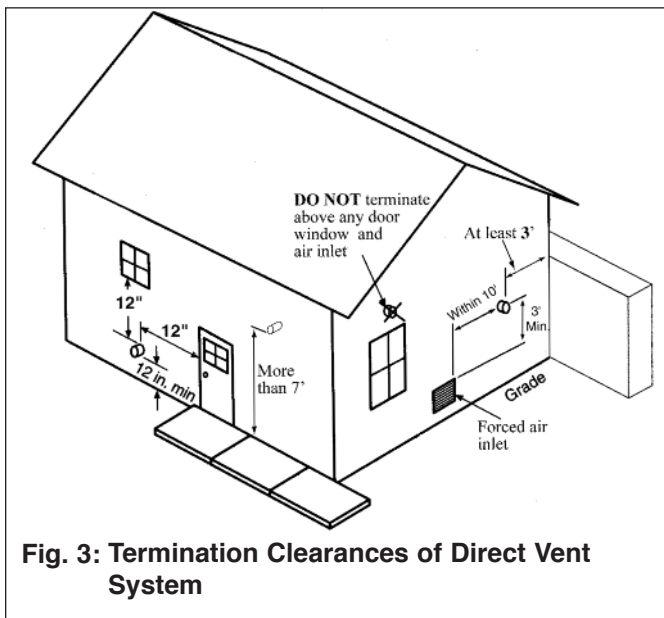

Fig. 2: Direct Vent - Vertical Termination of Vent and Combustion Air Piping.

- f. Locate the vent termination to prevent possible condensate damage to exterior finishes.
 - g. Avoid locations of possible accidental contact of flue vapors with people or pets.
6. The vent termination must also maintain the following clearances; as shown in Fig.3.
- a. At least 3 feet from adjacent walls
 - b. At least 3 feet below roof over hangs
 - c. At least 7 feet above any public walkways
 - d. At least 3 feet above any forced air intake within 10 feet (does not apply to the combustion air inlet of a direct vent appliance).
 - e. No closer than 12" below or horizontally from any door or window or gravity air inlet.
 - f. Must be at least 4 feet from any electric meters, gas meters-regulators, relief valves or other equipment. Never terminate the vent above or below any of these items within 4 feet horizontally.



7. Locate the vent and combustion air terminations in a manner to protect from damage by foreign objects, such as stones, balls, or buildup of leaves or sediment.
8. Do not connect any other appliance to the vent pipe or multiple boilers to a common vent pipe.

Direct Vent - Vent Installation - Through the Roof

1. Vent and Combustion Air Penetration
 - Vent pipe penetration through combustible or non-combustible wall material should maintain a minimum 1/4" clearance. The diameter of the penetration hole should be 4" minimum for 3" pipe or 5" minimum for 4" pipe.
 - Combustion air pipe penetration can maintain zero clearance. The diameter of the penetration hole should be 3 1/2" minimum for 3" pipe or 4-1/2" minimum for 4" pipe.
2. The installer must use a galvanized metal thimble for the vent pipe penetration.
3. Locate the vent and combustion air pipe penetrations to provide clearances as described in Fig. 1 & Fig. 2 on page 6.
4. The installer must comply with all local codes for isolating the vent and combustion air pipes as they pass through floors, ceilings and roofs.
5. The installer should provide adequate flashing and sealing boots sized for the vent pipe and combustion air pipe.

Termination Fittings - Through the Roof

1. The vent and combustion air terminations must include a factory supplied "bird screen" installed as shown in Figs. 4, 5 & 6 on page 8.
2. The combustion air piping must terminate in an upside down "U" shape fashion using two 90° elbows as shown in Fig. 1 page 6 or with a tee as shown in Fig. 2 on page 6.
3. The vent piping must terminate vertically with a coupling as shown in Figs. 1 & 2 page 6.



Do not extend the vent pipe above the roof beyond the dimensions shown in Fig. 1 & Fig. 2 on page 6. Extended exposure of the vent pipe could cause condensate to freeze and block the vent pipe.

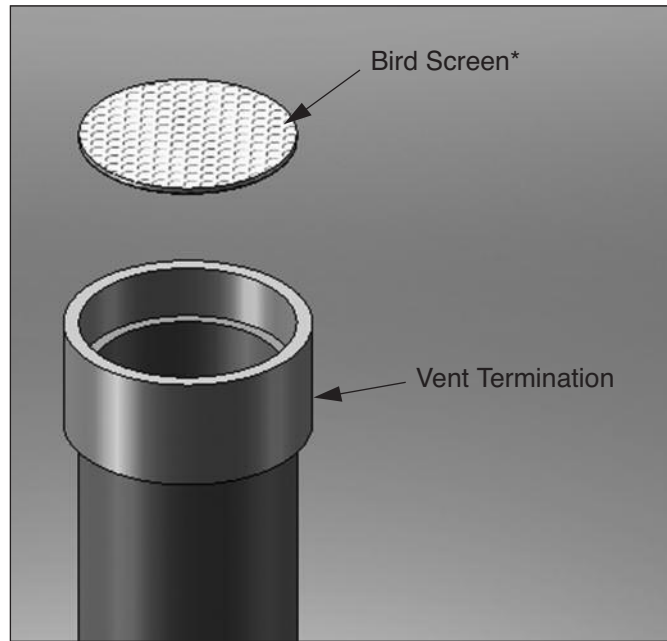

Fig. 4: Vertical Vent Bird Screen Installation

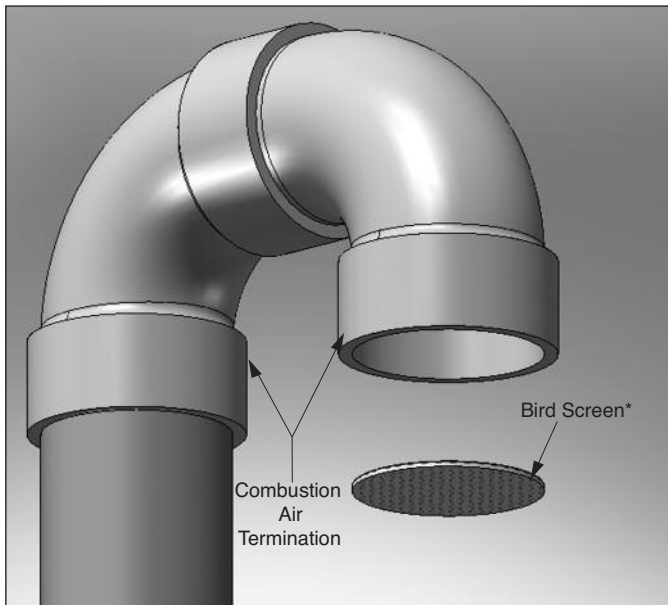

Fig. 5: Vertical Combustion Air Bird Screen Installation with 90° Elbow Termination

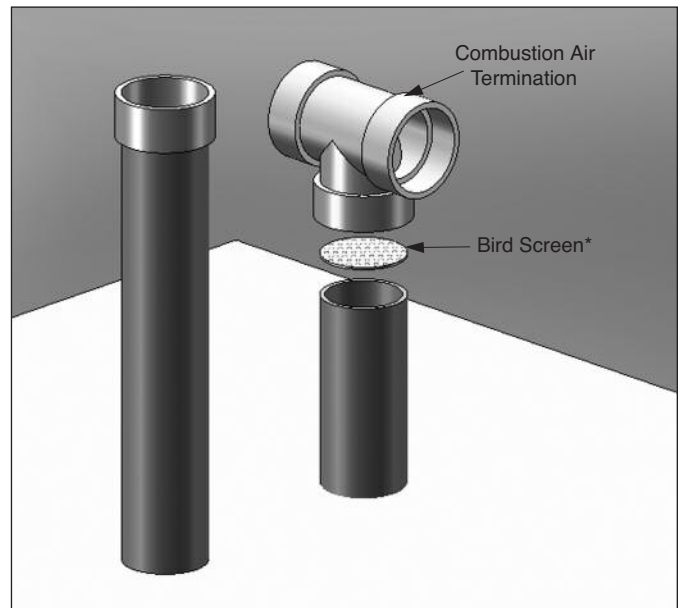

Fig. 6: Vertical Combustion Air Bird Screen Installation with Tee Termination

NOTICE

* Installer must install the factory supplied "bird screens" on the vent and combustion air terminations.

Direct Vent - Multiple Boiler Installation - Through the Roof

1. On installations of multiple PRESTIGE boilers, terminate the vent and combustion air piping as described in this manual.
2. The roof penetration of the vent and combustion air piping should be such that the combustion air inlet is a minimum 12" from the adjacent vent pipe of the other boiler for installations in the U.S. as shown in Fig. 7. For installations in Canada, provide clearances as required by CSA B149.1 or 149.2.

NOTICE

The combustion air inlet of the PRESTIGE is defined as being part of a direct vent system. It is not considered as a forced air intake. The required clearance of an adjacent boiler vent to a forced air inlet does not apply in a multiple installation of PRESTIGE boilers.

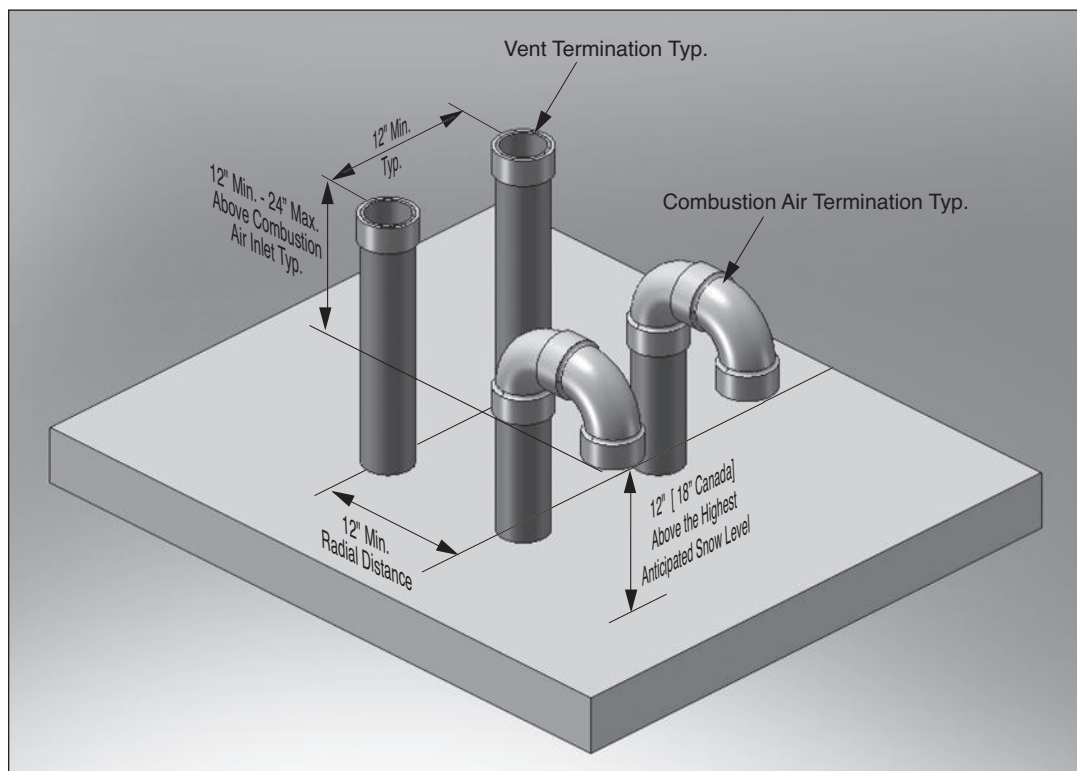

Fig. 7: Direct Vent - Vertical Termination of Multiple Boilers

Direct Vent - Horizontal - Sidewall

NOTICE

Installation of the vent and combustion air piping must comply with local codes and requirements and with the National Fuel Gas Code NFPA 54, ANSI Z223.1 for installations in the U.S. or CSA B149.1 or B149.2 for installations in Canada.

NOTICE

For direct vent (sidewall) installations in the Commonwealth of Massachusetts, the installer must comply with the additional requirements outlined on page 31 and 32.

⚠ WARNING

A gas vent extending through a sidewall should not terminate near an adjacent wall or below any building extensions such as roof eaves, balconies or decks. Failure to comply with the required clearances in this manual could result in severe personal injury, death or substantial property damage.

BEST PRACTICE

To reduce the potential of the combustion air inlet freezing up it is recommended to separate the vent and air terminations in both a horizontal and vertical plain as shown in figures 8 through 12 on pages 11 and 12.

BEST PRACTICE

If the vent is terminated on a sidewall which is subject to high winds it is recommended to terminate the vent using a 45° elbow or tee. A tee provides the best protection against wind but can expose the exterior of the house to condensate, while a 45° elbow provides improved protection from both wind and condensate.

Determine Termination Location

Locate the vent and combustion air termination using the following guidelines:

1. The total length of the vent or combustion air piping must not exceed the limits given in Table 1 on page 3.

NOTICE

DO NOT include the 45° or 90° elbows or tee used to terminate the combustion air inlet and vent exterior of the building when determining the total length of pipe.

2. The combustion air pipe must terminate using a 90° elbow directed away from the vent termination. The combustion air termination must be installed 12" minimum above grade / highest anticipated snow level and as shown in Figs. 8 through 15 page 11 & 12.

NOTICE

The combustion air termination can be placed on either side of the vent termination. The terminations must be a minimum 12" apart. The combustion air termination must be directed away from the vent see Figs. 10 through 15 page 11 & 12. The combustion air termination must be directed down for Figs. 8 and 9 pages 11 & 12.

3. The vent pipe can terminate:
 - Using a 90° elbow as shown in Fig. 8 or 10, page 11.
 - Using coupling as shown in Figs. 9 or 13, page 11 or 12.
 - Using a tee as shown in Figs. 11 or 14, page 11 or 12.
 - Using a 45° elbow as shown in Figs. 12 or 15, page 12.

The vent termination must be installed 12" minimum above grade / highest anticipated snow level.

⚠ WARNING

Do not extend the vent pipe outside the sidewall beyond the dimensions shown in Figs 8 through 15. Extended exposure of the vent pipe could cause condensate to freeze and block the vent pipe.

4. The combustion air and vent pipe center lines must be a minimum of 12" apart as shown in Figs. 8 through 15 pages 11 & 12.

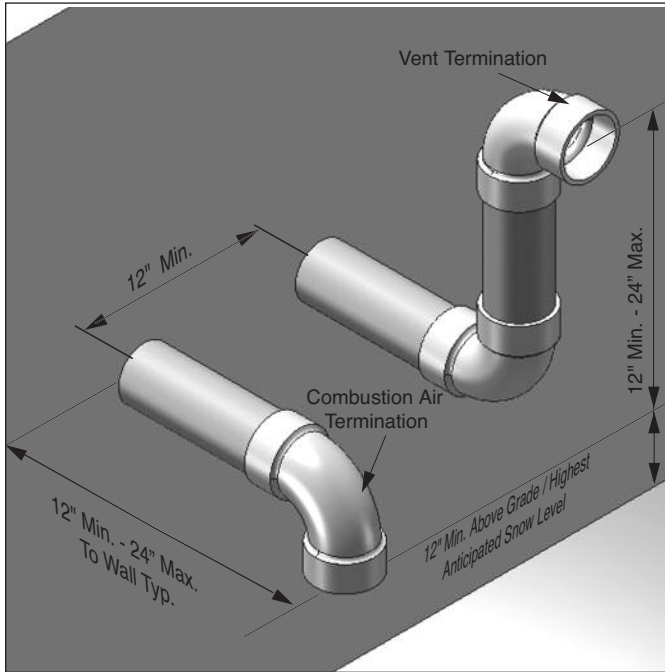

Fig. 8: Direct Vent - Sidewall Termination of Vent and Combustion Air Piping

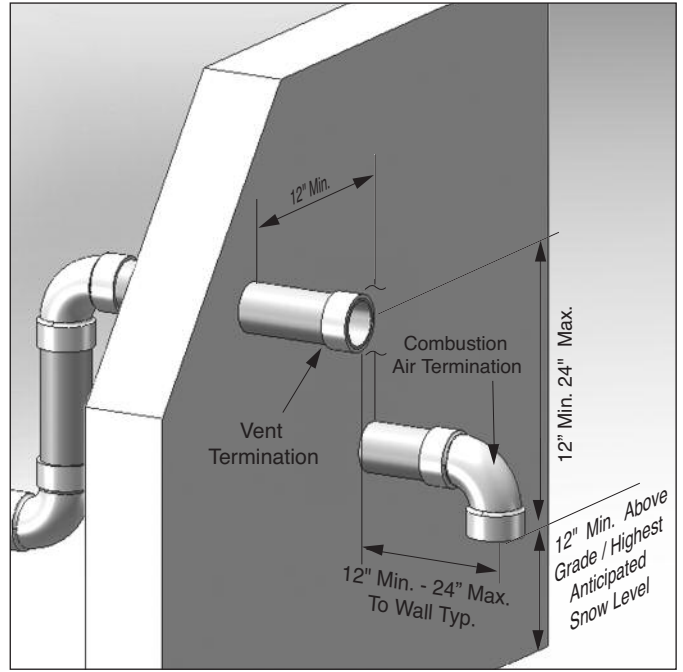

Fig. 9: Direct Vent - Alternate Sidewall Termination of Vent and Combustion Air Piping

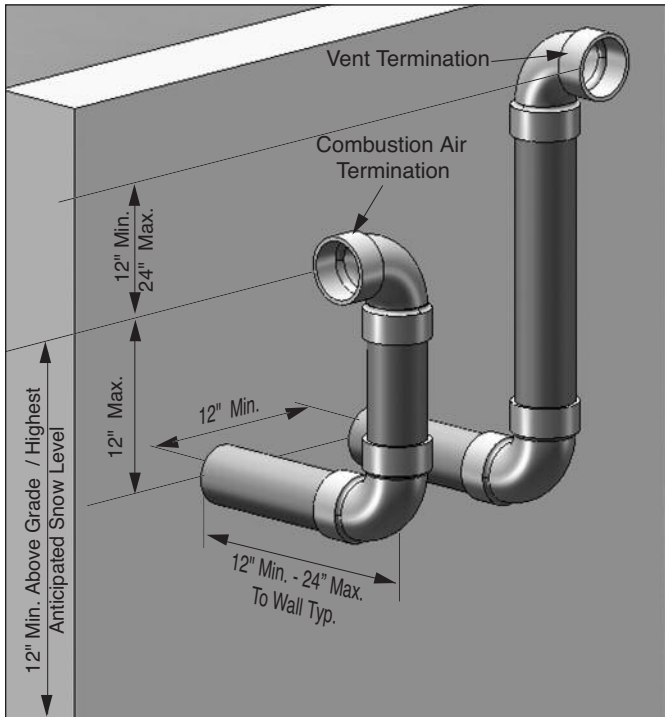

Fig. 10: Direct Vent - Sidewall Snorkel Termination of Vent and Combustion Air Piping

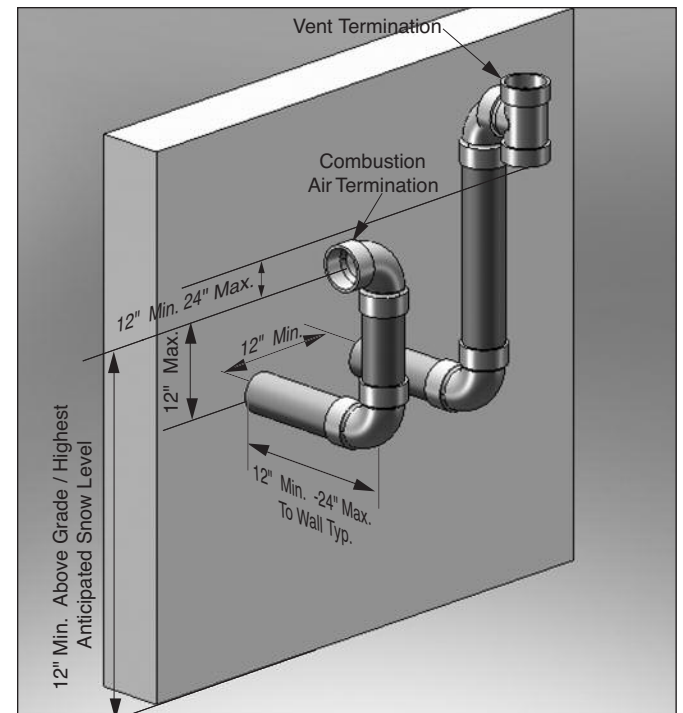

Fig. 11: Direct Vent - Sidewall Snorkel Termination of Vent and Combustion Air Piping with Tee Vent Termination

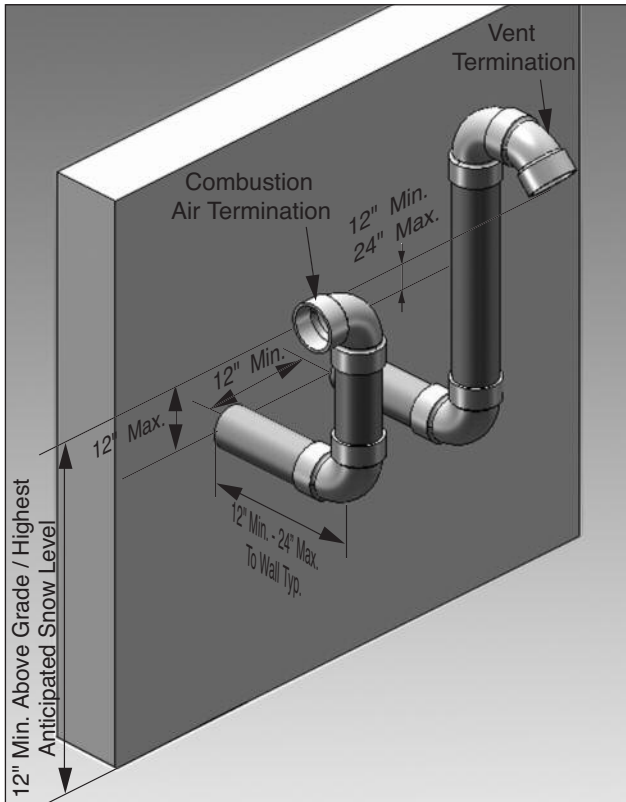

Fig. 12: Direct Vent - Sidewall Snorkel Termination of Vent and Combustion Air Piping with 45° Vent Termination

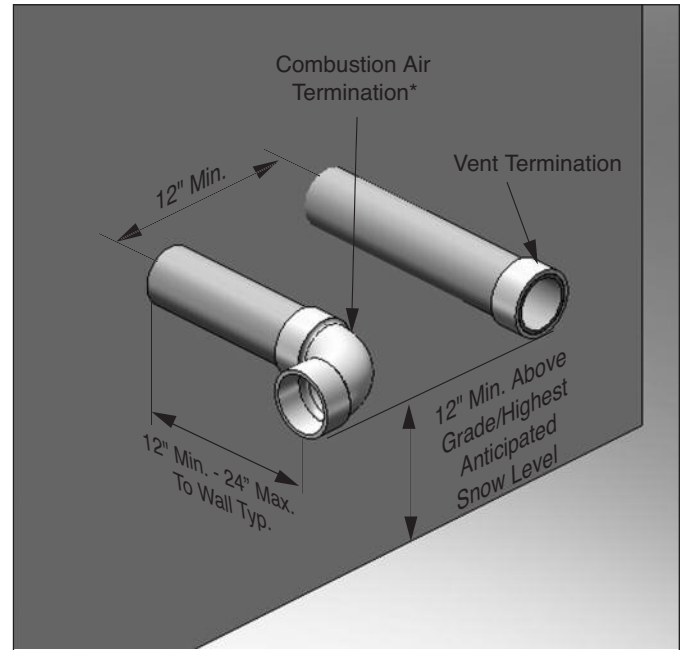

Fig. 13: Direct Vent - Sidewall Termination of Vent and Combustion Air Piping with Coupling Vent Termination

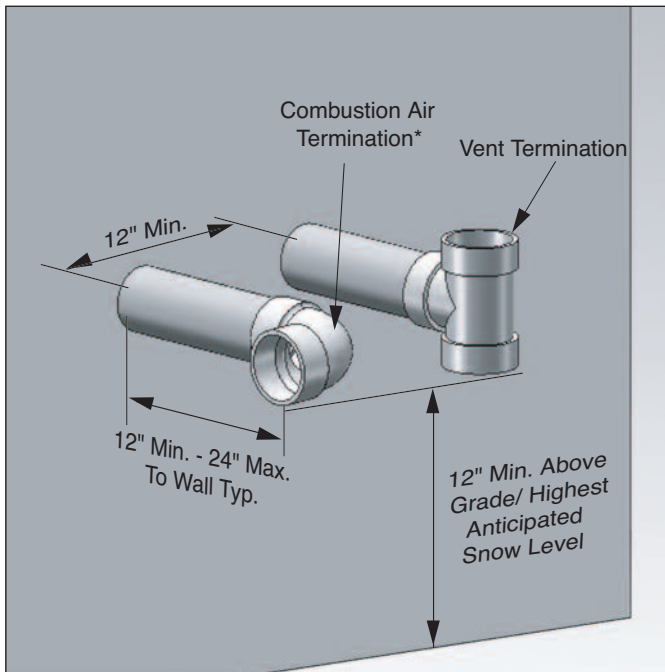

Fig. 14: Direct Vent - Sidewall Termination of Vent and Combustion Air Piping with Tee Vent Termination

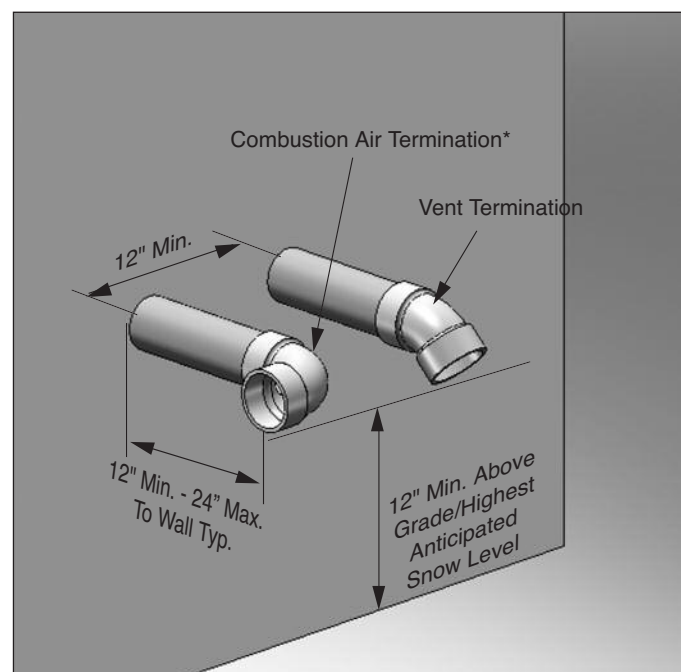

Fig. 15: Direct Vent - Sidewall Termination of Vent and Combustion Air Piping with 45° Vent Termination

NOTICE

* Combustion Air Termination should slope downward at 15° angle.

5. The following should be considered when determining the location of the vent and combustion air termination:
 - a. Locate the vent termination where flue vapors will not damage surrounding shrubs, plants, air conditioning equipment or be objectionable to the homeowner.
 - b. The flue products will form a noticeable plume of water vapor as they condense in colder air. Avoid terminating the vent in areas where the plume could obstruct window views.
 - c. Prevailing winds could cause freezing of flue gas condensation and a buildup of water / ice on surrounding plants, building surfaces or combustion air inlet.
 - d. Avoid locations where prevailing winds could affect the performance of the boiler or cause recirculation of the flue gases, such as inside corners of buildings, near adjacent buildings, vertical surfaces, window wells, stairwells, alcoves, courtyards, or other recessed areas.
 - e. Do not terminate the vent above doors or windows: flue condensate could freeze causing ice formations.
 - f. Locate the vent termination to prevent possible condensate damage to exterior finishes.
 - g. Avoid locations of possible accidental contact of flue vapors with people or pets.
6. The vent termination must also maintain the following clearances; as shown in Fig.3, page 7.
 - a. At least 3 feet from adjacent walls
 - b. At least 3 feet below roof overhangs
 - c. At least 7 feet above any public walkways
 - d. At least 3 feet above any forced air intake within 10 feet (does not apply to the combustion air inlet of a direct vent appliance).
 - e. No closer than 12" below or horizontally from any door, window or gravity air inlet.
- f. Must be at least 4 feet from electric meters, gas meters-regulators, relief valves or other equipment. Never terminate the vent above or below any of these items or within 4 feet horizontally.
- g. A minimum of 12" or a maximum of 24" beyond the exterior wall.
7. The combustion air termination must extend a minimum of 12" beyond the exterior wall.
8. Locate the vent and combustion air terminations in a manner so as to protect from damage by foreign objects, such as stones, balls, buildup of leaves or sediment.
9. Do not connect any other appliance to the vent pipe or multiple boilers to a common vent pipe.

Direct Vent - Vent Installation - Sidewall

1. Vent and Combustion Air Penetration
 - Vent pipe penetration through combustible or non-combustible wall material should maintain a minimum 1/4" clearance. The diameter of the penetration hole should be 4" minimum for 3" pipe or 5" minimum for 4" pipe.
 - Combustion air pipe penetration can maintain zero clearance. The diameter of the penetration hole should be 3 1/2" minimum for 3" pipe or 4 1/2" minimum for 4" pipe.
2. The installer must use a galvanized metal thimble for the vent pipe penetration.
3. Locate the vent and combustion air pipe penetrations to provide clearances as described in Figs. 8 through 15 pages 11 and 12.
4. The installer must comply with all local codes for isolating the vent pipe as it passes through floors and walls.
5. The installer should seal all exterior openings around penetration with an exterior silicon caulk.

Termination Fittings - Sidewall

1. The vent and combustion air terminations must include a factory supplied "bird screen" installed as shown in Figs. 16 through 19 page 15.
2. The combustion air pipe must terminate using a 90° elbow as shown in Figs. 8 through 15 page 11 and 12.
3. The vent pipe can terminate:
 - Using a 90° elbow as shown in Fig. 8 or 10 page 11.
 - Using coupling as shown in Fig. 9 or 13 page 11 or 12.
 - Using a tee as shown in Fig. 11 or 14 page 11 or 12.
 - Using a 45° elbow as shown in Fig. 12 or 15 page 12.

The vent termination must be installed 12" minimum above grade / highest anticipated snow level.



Do not extend the vent pipe outside the sidewall beyond the dimensions shown in Figs. 8 through 15. Extended exposure of the vent pipe could cause condensate to freeze and block the vent pipe.

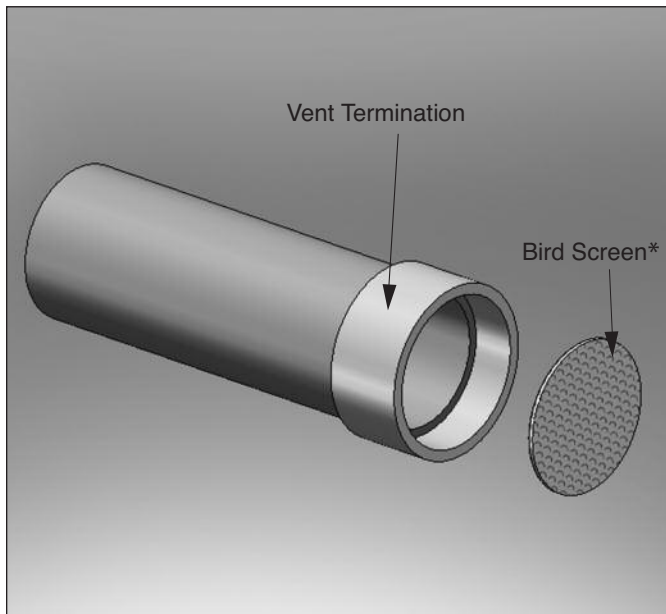

Fig. 16: Horizontal Vent Bird Screen Installation with Coupling Termination

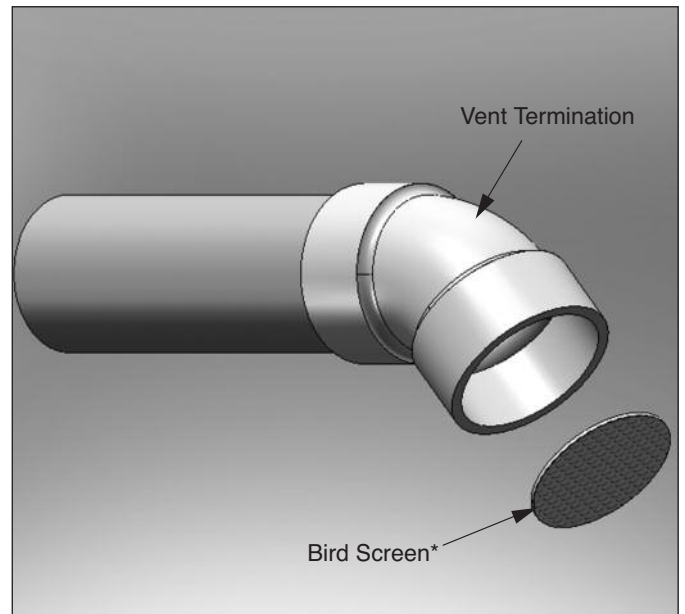

Fig. 17: Horizontal Vent Bird Screen Installation with 45° Elbow Termination

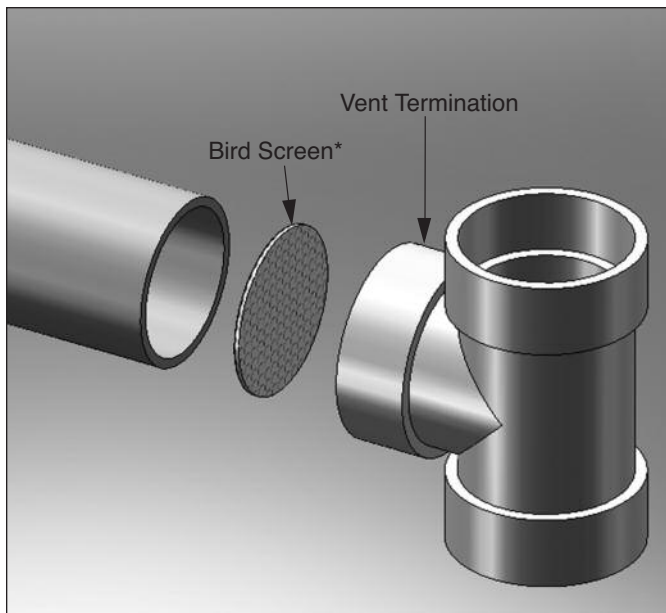

Fig. 18: Horizontal Vent Bird Screen Installation with Tee Termination

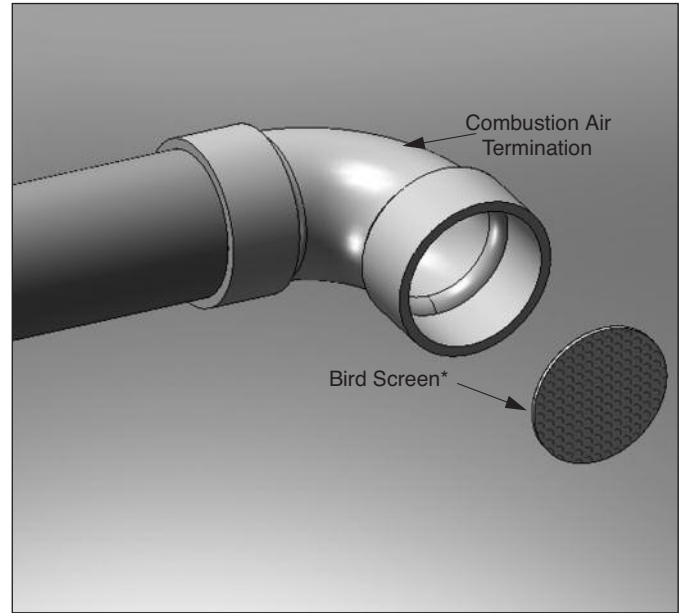

Fig. 19: Horizontal Combustion Air Bird Screen Installation with 90° Elbow Termination

NOTICE

* Installer must install the factory supplied “bird screens” on the vent and combustion air inlet terminations.

Direct Vent - Multiple Boiler Installation - Sidewall

1. On installations of multiple PRESTIGE boilers, terminate each vent and combustion air pipe as described in this manual.
2. The wall penetration of the vent and combustion air pipe should be such that the combustion air inlet is a minimum 12" from the adjacent vent pipe of the other boiler for installations in the U.S as shown in Fig. 20. For installations in Canada, provide clearances as required by CSA B149.1 or 149.2.

NOTICE

The combustion air inlet of the PRESTIGE is defined as being part of a direct vent system. It is not considered as a forced air intake. The required clearance of an adjacent boiler vent to a forced air inlet does not apply in a multiple installation of PRESTIGE boilers.

NOTICE

Fig. 20 shows one option for vent and combustion air terminations of multiple PRESTIGE boilers. Any termination option shown in Figs. 8 through 12 page 11 and 12 can be used for multiple PRESTIGE boilers. The 12" minimum distance between centerlines of the combustion air and vent piping must be maintained for any chosen option.

NOTICE

Reference Figs. 8 through 12 page 11 and 12 for the configuration dimensions for the vent and combustion air inlet terminations for each unit installed in a multiple installation.

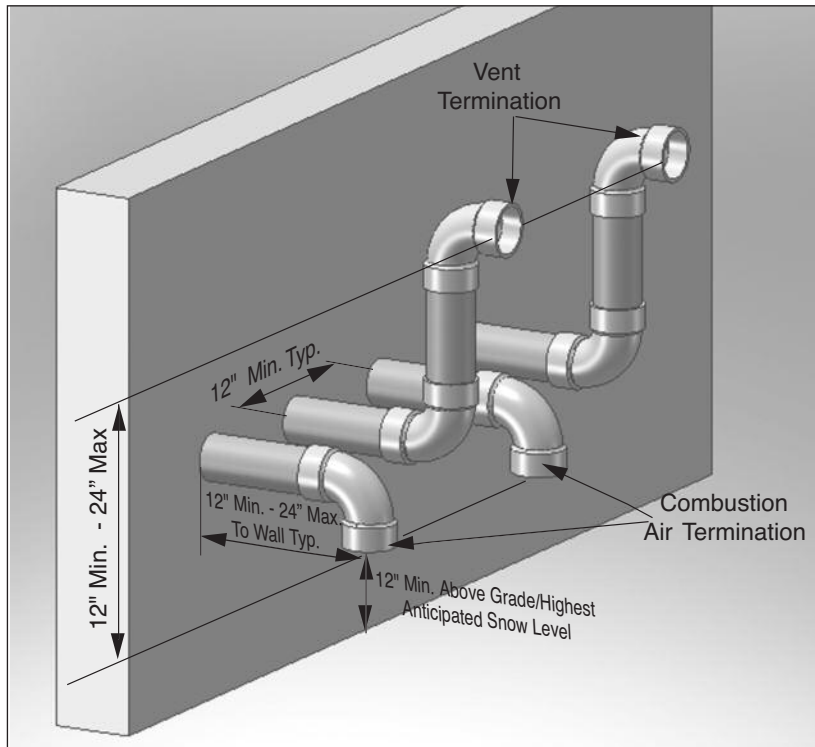

Fig. 20: Direct Vent - Horizontal Termination of Multiple Boilers

Direct Vent - Vertical Vent and Sidewall Combustion Air

NOTICE

Installation of the vent and combustion air piping must comply with local codes and requirements and with the National Fuel Gas Code NFPA 54, ANSI Z223.1 for installations in the U.S. or CSA B149.1 or B149.2 for installations in Canada.

NOTICE

When using an inoperative chimney as a means of a chase for the vent, the surrounding space within the chimney cannot be used to draw combustion air or vent another appliance.

WARNING

A gas vent extending through a roof should not terminate near an adjacent wall or below any building extensions such as roof eaves, balconies or decks. Failure to comply with the required clearances in this manual could result in severe personal injury, death or substantial property damage.

Determine Termination Location

Locate the vent and combustion air termination using the following guidelines:

1. The total length of the vent or combustion air piping must not exceed the limits given in Table 1 on page 3.

NOTICE

Do not include the 90° elbow or coupling used to terminate the combustion air inlet or vent exterior of the building when determining the total length of pipe.

2. The combustion air piping must terminate with a 90° elbow. Fig. 21 shows a snorkel termination option. The combustion air pipe can also terminate using a 90° elbow directed down or to the left or right as shown in figures 8 or 13 page 11 or 12. The termination must be installed 12" minimum above grade / highest anticipated snow level and as shown in Fig. 8 page 11 or Fig. 13 page 12 or Fig. 21.
3. The vent must terminate vertically with a coupling to accept the bird screen and must be located 12" [18" Canada] above the highest anticipated snow level.

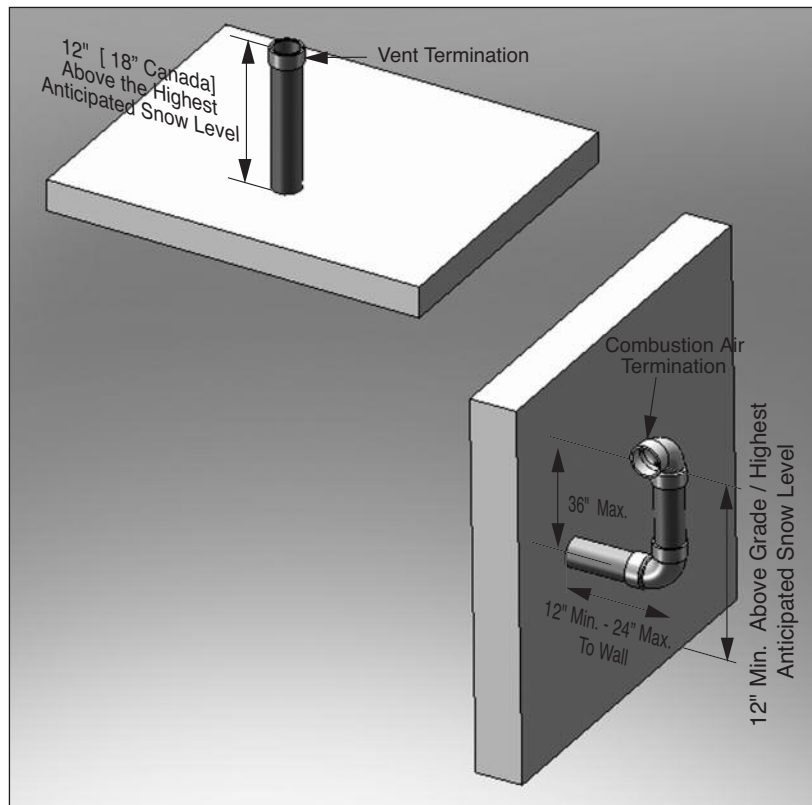

Fig. 21: Direct Vent - Vertical Vent and Side Wall Combustion Air

4. The following should be considered when determining the location of the vent and combustion air termination:
 - a. Locate the vent termination where flue vapors will not damage surrounding shrubs, plants or air conditioning equipment or be objectionable to the homeowner.
 - b. The flue products will form a noticeable plume of water vapor as they condense in colder air. Avoid terminating the vent in areas where the plume could obstruct window views.
 - c. Prevailing winds could cause freezing of flue gas condensation and a buildup of water / ice on surrounding plants, building surfaces or combustion air inlet.
 - d. Avoid locations where prevailing winds could affect the performance of the boiler or cause recirculation of the flue gases, such as inside corners of buildings, near adjacent buildings, vertical surfaces, window wells, stairwells, alcoves, courtyards, or other recessed areas.
 - e. Do not terminate the vent above doors or windows: flue condensate could freeze causing ice formations.
 - f. Locate the vent termination to prevent possible condensate damage to exterior finishes.
 - g. Avoid locations of possible accidental contact of flue vapors with people or pets.
5. The vent termination must also maintain the following clearances; as shown in Fig.3, page 7.
 - a. At least 3 feet from adjacent walls
 - b. At least 3 feet below roof over hangs
 - c. At least 7 feet above any public walkways
 - d. At least 3 feet above any forced air intake within 10 feet (does not apply to the combustion air inlet of a direct vent appliance).
 - e. No closer than 12" below or horizontally from any door or window or gravity air inlet.
 - f. Must be at least 4 feet from any electric meters, gas meters-regulators, relief valves or other equipment. Never terminate the vent above or below any of these items within 4 feet horizontally.
6. The combustion air termination must extend a minimum of 12" beyond the exterior wall.

7. Locate the vent termination and combustion air inlet in a manner to protect from damage by foreign objects, such as stones, balls, or buildup of leaves or sediment.
8. Do not connect any other appliance to the vent pipe or multiple boilers to a common vent pipe.

Direct Vent - Vent Installation - Through the Roof

1. Vent pipe penetration through combustible or non-combustible wall material should maintain a minimum 1/4" clearance. The diameter of the penetration hole should be 4" minimum for 3" pipe or 5" minimum for 4" pipe.
2. The installer must use a galvanized metal thimble for the vent pipe penetration.
3. The vent must terminate 12" [18" Canada] above the highest anticipated snow level.
4. The installer must comply with all local codes for isolating the vent pipe as it passes through floors, ceilings and roofs.
5. The installer should provide adequate flashing and sealing boots sized for the vent pipe.

Direct Vent - Combustion Air installation - Sidewall

1. Combustion air pipe penetration can maintain zero clearance. The diameter of the penetration hole should be 3 1/2" minimum for 3" pipe or 4 1/2" minimum for 4" pipe.
2. The combustion air termination must be installed 12" minimum above grade / highest anticipated snow level and as shown in Fig. 8 or 10 or 13 pages 11 and 12.
3. The installer must comply with all local codes for isolating the combustion air pipe as it passes through floors and walls.
4. The installer should seal all exterior openings around penetration with an exterior silicon caulk.

Termination Fittings

1. The vent and combustion air terminations must include a factory supplied “bird screen” installed as shown in Fig. 4 page 8 & Fig. 19 page 15.
2. The combustion air piping must terminate through the sidewall using a 90° elbow as shown in Fig. 8 through 11, page 11 or Fig.12 through 15 page 12 .
3. The vent piping must terminate vertically through the roof with a coupling to accept the bird screen and must be located 12” [18” Canada] above the highest anticipated snow level.



WARNING

Do not extend the vent pipe above the roof beyond the dimension shown in Fig. 21 on page 17. Extended exposure of the vent pipe could cause condensate to freeze and block the vent pipe.

Direct Vent - Multiple Boiler Installation - Vertical Vent and Sidewall Combustion Air

1. On installations of multiple PRESTIGE boilers, terminate each vent and combustion air piping as described in this manual.
2. Each vent and combustion air termination must be a minimum 12” from the adjacent termination for installations in the U.S. as shown in Fig. 22. For installations in Canada, provide clearances as required by CSA B149.1 or 149.2.

NOTICE

The combustion air inlet of the PRESTIGE is defined as being part of a direct vent system. It is not considered as a forced air intake. The required clearance of an adjacent boiler vent to a forced air inlet does not apply in a multiple installation of PRESTIGE boilers.

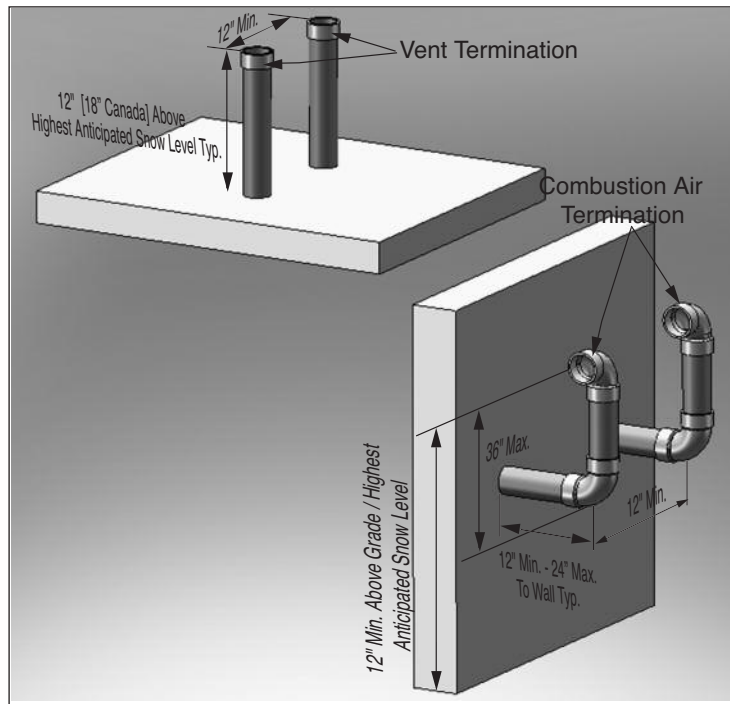

Fig. 22: Direct Vent - Vertical Termination of Vent and Sidewall Termination of Combustion Air of Multiple Boilers

3" to 4" Vent/Combustion Air Transition

NOTICE

This section outlines the installation of Venting and Combustion Air for the PRESTIGE 60, 110, 175, 250 and EXCELLENCE. When venting with 4" pipe, the vent system must transition from the 3" outlet of the boiler to the 4" vent system.

- The transition from 3" vent system to 4" vent system must occur within 5 feet of the boiler vent outlet.
- The transition from 3" vent to 4" vent must occur in a vertical run only.

WARNING

Transition of 3" vent to 4" vent in a horizontal run may result in pooling of the condensate and potential vent blockage. Failure to comply can result in death, serious injury or substantial property damage.

- The 4" vent should not transition back to 3" vent at any point in the vent system except when using Triangle Tube's optional concentric vent termination kit, see kit instructions for details.
- The total equivalent length of the 3" vent and 4" vent combined shall not exceed the length listed for a 4" vent system Table 1, page 3.
- The combustion air piping shall transition from 3" to 4" in the same manner as the vent system.
- The total equivalent length of 3" and 4" combustion air piping combined shall not exceed the length listed for combustion air in Table 1, page 3.

Insert Piping to PRESTIGE Adapters

1. The installer must clean, deburr and chamfer the pipe ends.

WARNING

The pipe ends must be smooth, free of sharp edges chamfer and wiped clean to prevent possible damage to the sealing gasket in the vent and combustion air adapters. Failure to comply with this requirement could result in leakage of flue products causing possible severe personal injury or death.

2. Prior to inserting the pipe, inspect the vent and combustion air adapters to verify there are no obstructions or packing material inside the adapters and the gaskets are in place.
3. Ensure the adapter banding strap is loose prior to inserting the pipe.
4. Apply a small amount of silicon grease or water to the insertion end of the pipe to ease insertion into the adapter.
5. Insert the pipe into the adapter until it is fully seated.

WARNING

Do not apply excessive force, twist or bend the adapter or vent / combustion air pipe when inserting. The adapter gasket could be damaged resulting in possible flue gas leakage.

6. Secure the vent and combustion air pipe by tightening the adapter banding strap. Do not over tighten the strap. The seal is made with gasket inside the adapter.

Vent and Combustion Air Piping Installation Guidelines

1. The installer should install the vent / combustion air piping working from the boiler to the piping termination. The piping should not exceed the lengths given in Table 1 page 3 for either the vent or combustion air.
2. The installer should cut the pipe to the required lengths and deburr the inside and outside of both ends.
3. The installer should chamfer the outside of the pipe ends to allow even distribution of cement when joining.

4. The installer should dry assemble the vent or combustion air system prior to assembling any joints to ensure proper fit.
5. The pipe ends and fittings should be cleaned and dried thoroughly prior to assembly of the joint.
6. When assembling a joint the installer should:
 - a. Handle fitting and pipes carefully to prevent contamination of surfaces
 - b. Apply a liberal amount of primer to both surfaces - the end of the pipe and the insert socket of the fitting.
 - c. Apply a light uniform coating of approved cement to both surfaces - the end of the pipe and the insert socket of the fitting, while the primer is still wet.
 - d. A second coat of approved cement should be applied to the mating surfaces. The installer should avoid, however, using too much cement on the socket of the fitting to prevent a buildup of cement on the inside.
 - e. With the cement still wet, the pipe end should be inserted into the socket of the fitting and twisted 1/4 of a full turn. Ensure the pipe end is inserted fully into the socket of the fitting.
 - f. Any excess cement should be wiped clean from the joint. Inspect the joint to ensure a smooth bead of cement is noticed around the entire joint seam.
7. The installer should use perforated metal strap hangers or equivalent pipe hangers suitable for plastic pipe to support the piping. The hangers must be spaced at a maximum of every 5 feet of horizontal and vertical run of piping. A support must be placed near the boiler and every change in direction vertical or horizontal (i.e elbow). Do not penetrate any part of the piping or vent system with fastener.

NOTICE

Pipe hangers should not be tightly clamped to pipe to allow for thermal expansion/contraction movement. Pipe clamps or hangers should not contain any sharp edges which can damage the pipe.

8. The vent and combustion air piping should be sloped continuously from the termination back to the boiler with at least 1/4" drop per foot of run. Do not allow any sags in the run of piping.

WARNING

Do not pitch the vent or combustion air piping downward away from the boiler. Potential condensate damage to the building exterior or to the surrounding landscape and/or potential risks of icing and blockage of the vent piping could occur.

9. Maintain a minimum clearance of 1/4" between the vent pipe and all materials, combustible or non-combustible. The installer must seal any wall, floor or ceiling penetrations as per local code requirements.

BEST PRACTICE

It is recommended that the installer uses the same number of elbows and length of piping on the venting and the combustion air inlet systems.

NOTICE

Do not insulate any vent pipe runs that pass through uncondition areas.

SECTION III - CATEGORY IV INSTALLATION OF VENT/AIR PIPING

A Category IV appliance utilizes uncontaminated indoor or outdoor air (surrounding the appliance) for combustion.

Category IV - Vertical - Through the Roof or Unused Chimney

NOTICE

Installation of the vent and combustion air piping must comply with local codes and requirements and with the National Fuel Gas Code NFPA 54, ANSI Z223.1 for installations in the U.S. or CSA B149.1 or B149.2 for installations in Canada.

NOTICE

When using an inoperative chimney as a means of a chase for the vent, the surrounding space within the chimney cannot be used to draw combustion air or vent another appliance.

WARNING

A gas vent extending through a roof should not terminate near an adjacent wall or below any building extensions such as roof eaves, balconies or decks. Failure to comply with the required clearances in this manual could result in severe personal injury, death or substantial property damage.

Determine Termination Location

Locate the vent and combustion air termination using the following guidelines:

1. The total length of the vent must not exceed the limits given in Table 1 on page 3.

NOTICE

Do not include the coupling used to terminate the vent exterior of the building when determining the total length of pipe.

2. The combustion air piping must terminate at the boiler with a 90° elbow.
3. The vent must terminate vertically with a coupling and must be located 12" [18 Canada] above the highest anticipated snow level as shown in Fig. 23.
4. The following should be considered when determining the location of the vent termination:
 - a. Locate the vent termination where flue vapors will not damage surrounding shrubs, plants or air conditioning equipment or be objectionable to the homeowner.
 - b. The flue products will form a noticeable plume as they condense in colder air. Avoid terminating the vent in areas where the plume could obstruct window views.
 - c. Prevailing winds could cause freezing of flue condensation and a buildup of water / ice on surrounding plants or building surfaces.

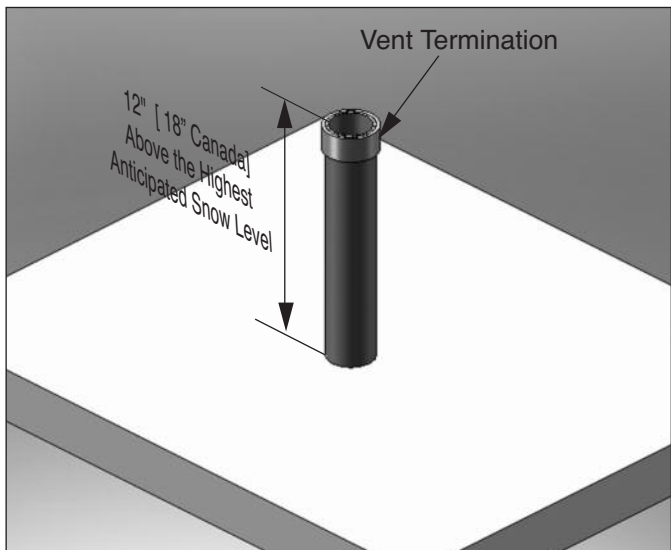

Fig. 23: Category - IV - Vertical Termination of Vent Pipe

- d. Avoid locations where prevailing winds could affect the performance of the boiler or cause recirculation of the flue gases, such as inside corners of buildings or near adjacent buildings or vertical surfaces, window wells, stairwells, alcoves, courtyards, or other recessed areas.
 - e. Do not terminate the vent above any doors or windows: flue condensate could freeze causing ice formations.
 - f. Locate the vent termination to prevent possible condensate damage to exterior finishes.
 - g. Avoid locations of possible accidental contact of flue vapors with people or pets.
5. The vent termination must also maintain the following clearances; as shown in Fig.24.
 - a. At least 3 feet from adjacent walls
 - b. At least 3 feet below roof over hangs
 - c. At least 7 feet above any public walkways
 - d. At least 3 feet above any forced air intake within 10 feet.
 - e. No closer than 4 feet below or horizontally from any door or window or gravity air inlet.
 6. Locate the vent termination in a manner to protect from damage by foreign objects, such as stones, balls, or to buildup of leaves and sediment.
 7. Do not connect any other appliance to the vent pipe or multiple boilers to a common vent pipe.

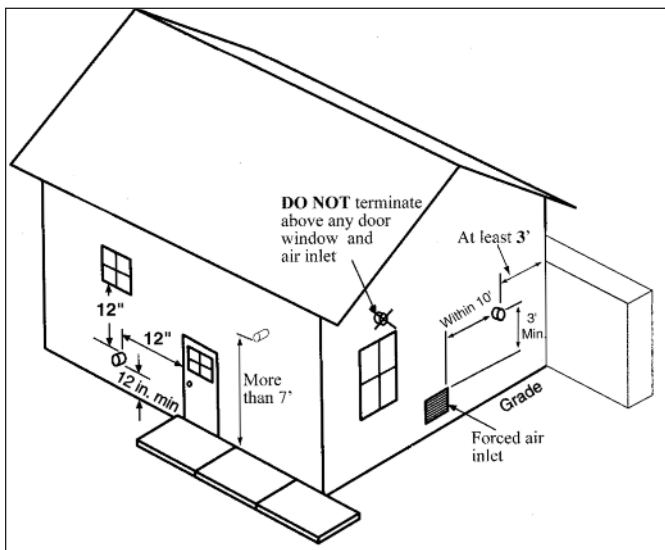

Fig. 24: Termination Clearances of Category IV System

Category IV - Vent Installation - Through the Roof

1. Vent Penetration

- Vent pipe penetration through combustible or non-combustible wall material should maintain a minimum 1/4" clearance. The diameter of the penetration hole should be 4" minimum for 3" pipe or 5" minimum for 4" pipe.
2. The installer must use a galvanized metal thimble for the vent pipe penetration.
 3. Locate the vent pipe penetration to provide clearances as described in Fig. 23 page 22.
 4. The installer must comply with all local codes for isolating the vent pipe as it passes through floors, ceilings and roofs.
 5. The installer should provide adequate flashing and a sealing boot sized for the vent pipe.

Termination Fittings - Through the Roof

1. The vent pipe and combustion air pipe terminations must include a factory supplied "bird screen" installed as shown in Figs 4. & 5 page 8.
2. The combustion air piping must terminate at the boiler with a 90° elbow.
3. The vent piping must terminate vertically with a coupling as shown in Fig. 23 page 22.

! WARNING

Do not extend the vent pipe above the roof beyond the given dimensions shown in Fig. 23 page 22. Extended exposure of the vent pipe could cause condensate to freeze and block the vent pipe.

Category IV - Multiple Boiler Installation - Through the Roof

1. On installations of multiple PRESTIGE boilers, terminate each vent pipe as described in this manual.
2. Each vent termination must be a minimum 12" from the adjacent termination for installations in the U.S. as shown in Fig. 25. For installations in Canada, provide clearances as required by CSA B149.1 or 149.2.

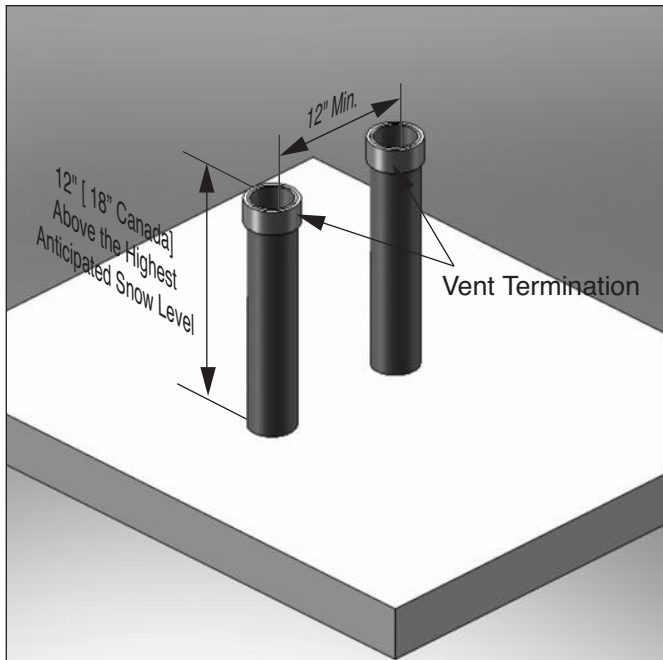

Fig. 25: Category IV- Vertical Termination of Multiple Boilers

Category IV - Horizontal - Sidewall

NOTICE

Installation of the vent and combustion air piping must comply with local codes and requirements and with the National Fuel Gas Code NFPA 54, ANSI Z223.1 for installations in the U.S. or CSA B149.1 or B149.2 for installations in Canada.

NOTICE

For direct vent (sidewall) installations in the Commonwealth of Massachusetts, the installer must comply with the additional requirements outlined on pages 31 and 32.

! WARNING

A gas vent extending through a sidewall should not terminate near an adjacent wall or below any building extensions such as roof eaves, balconies or decks. Failure to comply with the required clearances in this manual could result in severe personal injury, death or substantial property damage.

BEST PRACTICE

If the vent is terminated on a sidewall which is subject to high winds it is recommended to terminate the vent using a 45° elbow or tee. A tee provides the best protection against wind but can expose the exterior of the house to condensate, while a 45° elbow provides improved protection from both wind and condensate.

Determine Termination Location

Locate the vent and combustion air termination using the following guidelines:

1. The total length of the vent must not exceed the limits given in Table 1 on page 3.

NOTICE

DO NOT include the 45° or 90° elbow or tee used to terminate the vent exterior of the building when determining the total length of pipe.

2. The combustion air piping must terminate at the boiler with a 90° elbow.
3. The vent pipe can terminate:
 - Using a 90° elbow as shown in Fig. 29 page 26.
 - Using a coupling as shown in Fig. 26 page 26.
 - Using a tee as shown in Fig. 27 page 26 or Fig. 30 page 27 .
 - Using a 45° elbow as shown in Fig. 28 page 26 or Fig. 31 page 27.

The vent termination must be installed 12" minimum above grade / highest anticipated snow level.

WARNING

Do not extend the vent pipe outside the sidewall beyond the dimensions shown in Figs. 26 through 31 pages 26 and 27. Extended exposure of the vent pipe could cause condensate to freeze and block the vent pipe.

4. The following should be considered when determining the location of the vent termination:
 - a. Locate the vent termination where flue vapors will not damage surrounding shrubs, plants or air conditioning equipment or be objectionable to the homeowner.
 - b. The flue products will form a noticeable plume as they condense in colder air. Avoid terminating the vent in areas where the plume could obstruct window views.

- c. Prevailing winds could cause freezing of flue condensation and a buildup of water / ice on surrounding plants or building surfaces.
 - d. Avoid locations where prevailing winds could affect the performance of the boiler or cause recirculation of the flue gases, such as inside corners of buildings or near adjacent buildings or vertical surfaces, window wells, stairwells, alcoves, courtyards, or other recessed areas.
 - e. Do not terminate the vent above any doors or windows: flue condensate could freeze causing ice formations.
 - f. Locate the vent termination to prevent possible condensate damage to exterior finishes.
 - g. Avoid locations of possible accidental contact of flue vapors with persons or pets.
5. The vent termination must also maintain the following clearances; as shown in Fig.24, page 23.
 - a. At least 3 feet from adjacent walls
 - b. At least 3 feet below roof overhangs
 - c. At least 7 feet above any public walkways
 - d. At least 3 feet above any forced air intake within 10 feet.
 - e. No closer than 4 feet below or horizontally from any door or window or gravity air inlet.
 - f. Must be at least 4 feet from any electric meters, gas meters-regulators, relief valves or other equipment. Never terminate the vent above or below any of these items within 4 feet horizontally.
 - g. A minimum 12" or a maximum 24" beyond the exterior wall.
 6. The combustion air must terminate at the boiler with a 90° elbow.
 7. Locate the vent termination in a manner to protect from damage by foreign objects, such as stones or balls or subject to buildup of leaves or sediment.
 8. Do not connect any other appliance to the vent pipe or multiple boilers to a common vent pipe.

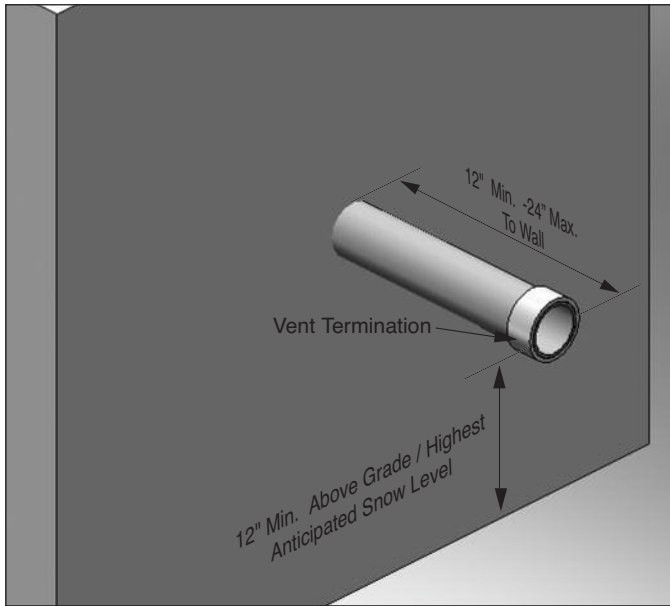

Fig. 26: Category IV - Sidewall Termination of Vent Pipe with Coupling Termination

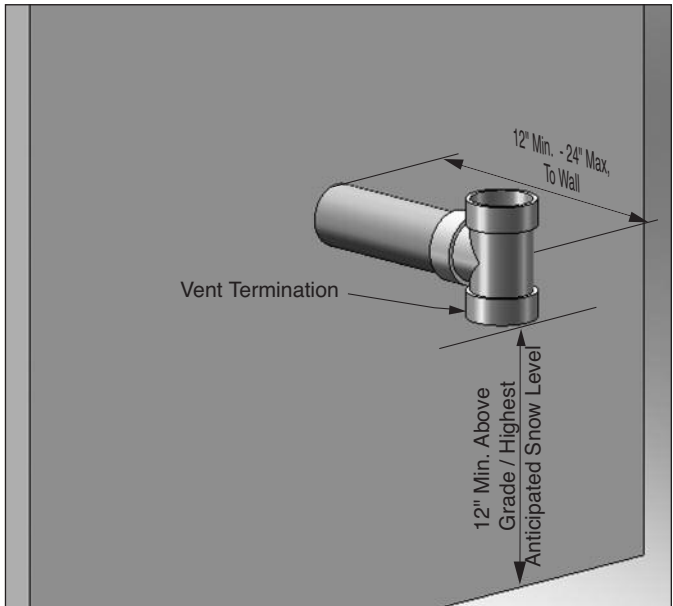

Fig. 27: Category IV - Sidewall Termination of Vent Pipe with Tee Termination

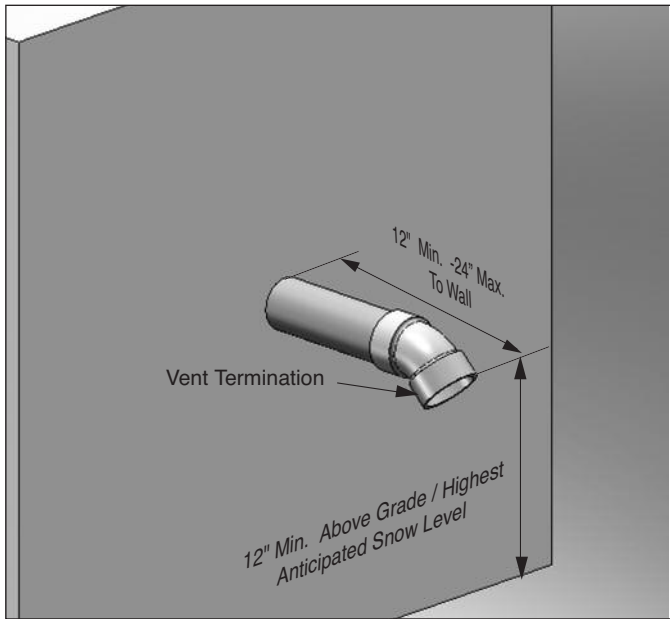

Fig. 28: Category IV - Sidewall Termination of Vent Pipe with 45° Termination

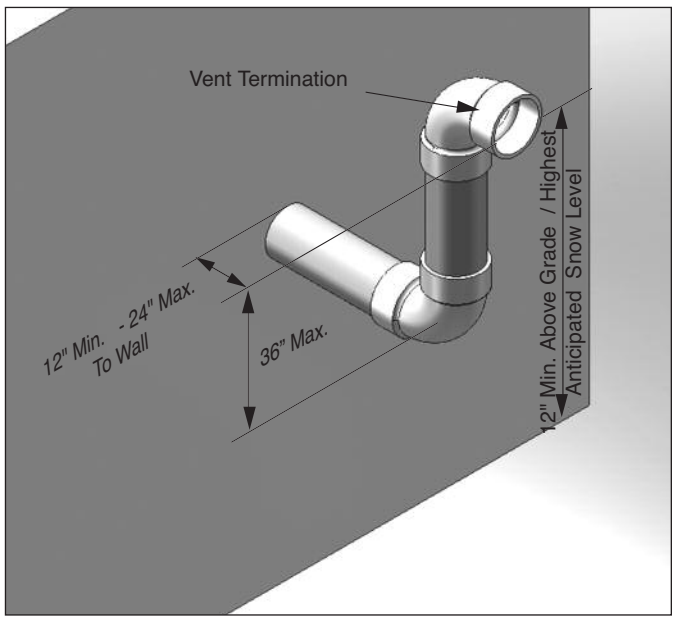

Fig. 29: Category IV - Sidewall Snorkel Termination of Vent Pipe with 90° Elbow Termination

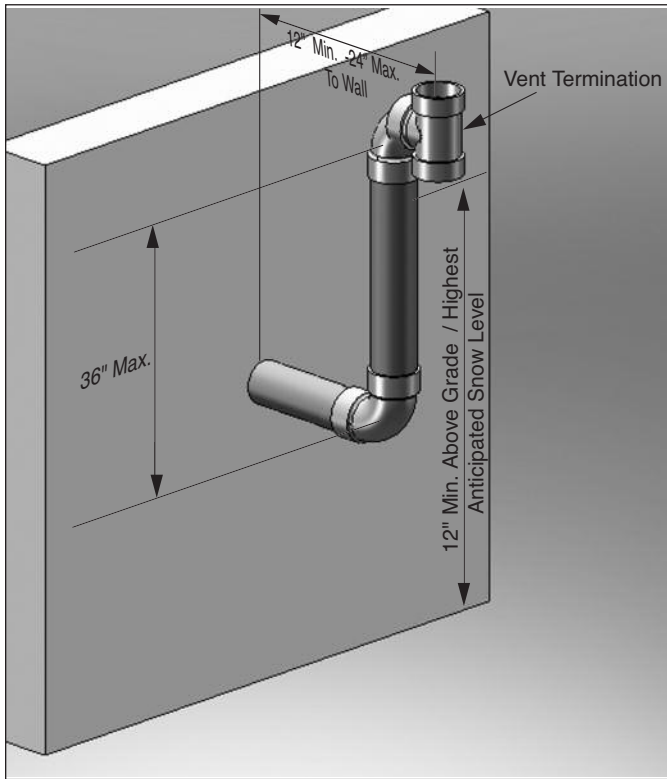

Fig. 30: Category IV - Sidewall Snorkel Termination of Vent Pipe with Tee Termination

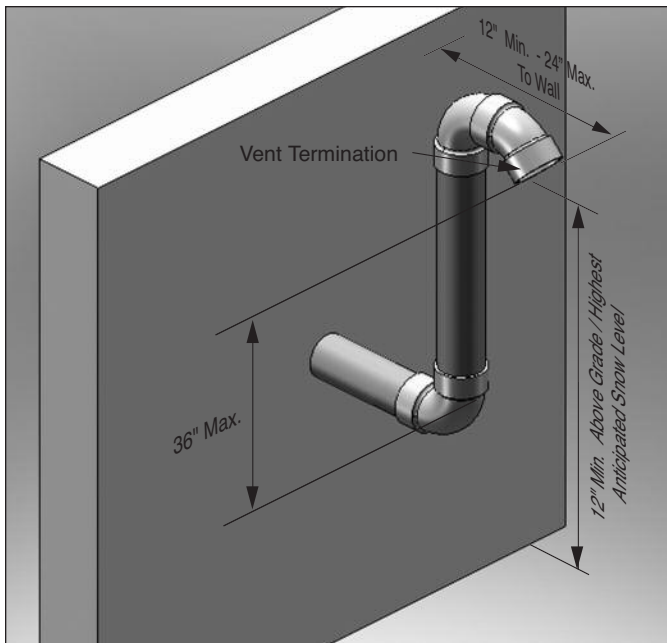

Fig. 31: Category IV - Sidewall Snorkel Termination of Vent Pipe with 45° Elbow Termination

Category IV - Vent Installation - Sidewall

1. Vent Penetration

- Vent pipe penetration through combustible or non-combustible wall material should maintain a minimum 1/4" clearance. The diameter of the penetration hole should be 4" minimum for 3" pipe or 5" minimum for 4" pipe.
2. The installer must use a galvanized metal thimble for the vent pipe penetration.
 3. Locate the vent pipe penetration to provide minimum clearances as described in Figs. 26 through 31 pages 26 and 27.
 4. The installer must comply with all local codes for isolating the vent pipe as it passes through floors and walls.
 5. The installer should seal all exterior openings around penetrations with an exterior silicon caulk.

Termination Fittings - Sidewall

1. The vent and combustion air terminations must include a factory supplied "bird screen" installed as shown in Figs: 16 through 19 page 15.
2. The combustion air piping must terminate at the boiler with a 90° elbow.
3. The vent pipe can terminate:
 - Using a 90° elbow as shown in Fig. 29 page 26.
 - Using a coupling as shown in Fig. 26 page 26.
 - Using a tee as shown in Fig. 27 page 26 or Fig. 30 page 27 .
 - Using a 45° elbow as shown in Fig. 28 page 26 or Fig. 31 page 27.

The vent termination must be installed 12" minimum above grade / highest anticipated snow level.



Do not extend the vent pipe outside the sidewall beyond the dimensions shown in Figs. 26 through 31 pages 26 and 27. Extended exposure of the vent pipe could cause condensate to freeze and block the vent pipe.

Category IV - Multiple Boiler Installation - Sidewall

1. On installations of multiple PRESTIGE boilers, terminate each vent pipe as described in this manual.
2. The wall penetration of the vent should be a minimum 12" from the adjacent vent pipe of another boiler for installations in the U.S as shown Fig. 32. For installations in Canada, provide clearances as required by CSA B149.1 or 149.2.

NOTICE

Fig. 32 shows one option for vent terminations of multiple PRESTIGE boilers. Any vent termination option shown in Figs. 26 through 31 pages 26 and 27 can be used for multiple PRESTIGE boilers. The 12" minimum distance between centerlines of the vent piping must be maintained for any chosen option.

NOTICE

Reference Figs. 26 through 31 pages 26 and 27 for the configuration dimensions of the vent for each unit installed in a multiple installation.

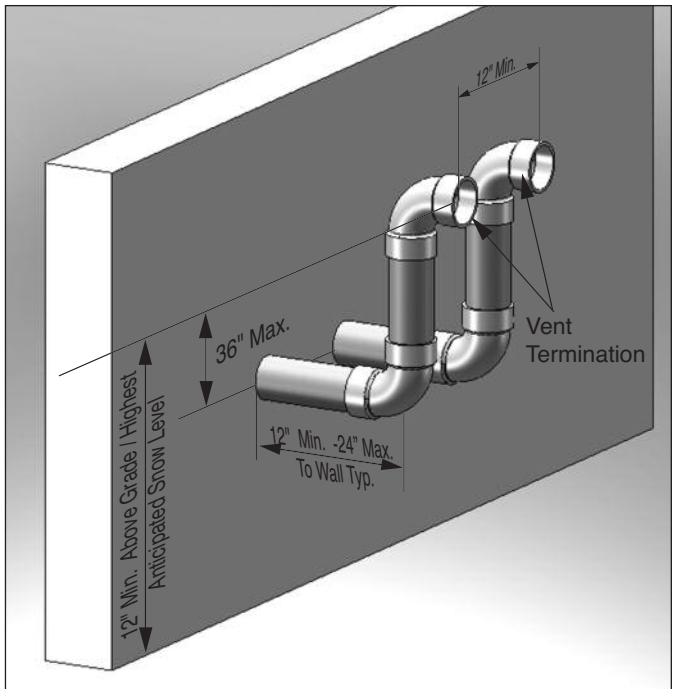

Fig. 32: Category IV - Multiple Boiler Sidewall Vent Terminations

3" to 4" Vent Transition

NOTICE

This section outlines the installation of Vent Piping for the PRESTIGE 60, 110, 175, 250 and EXCELLENCE. When venting with 4" pipe, the vent system must transition from the 3" outlet of the boiler to the 4" vent system.

- The transition from 3" vent system to 4" vent system must occur within 5 feet of the boiler vent outlet.
- The transition from 3" vent to 4" vent must occur in a vertical run only.

WARNING

Transition of 3" vent to 4" vent in a horizontal run may result in pooling of the condensate resulting in potential vent blockage. Failure to comply can result in death, serious injury or property damage.

- The 4" vent should not transition back to 3" vent at any point in the vent system except when using Triangle Tube's optional concentric vent termination kit, see kit instructions for details.
- The total equivalent length of the 3" vent and 4" vent combined shall not exceed the length listed for a 4" vent system Table 1, page 3.

Insert Piping to PRESTIGE Adapters

1. The installer must clean, deburr and chamfer the pipe ends.

WARNING

The pipe ends must be smooth, free of sharp edges chamfer and wiped clean to prevent possible damage to the sealing gasket in the vent and combustion air adapters. Failure to comply with this requirement could result in leakage of flue products causing possible severe personal injury or death.

2. Prior to inserting the pipe, inspect the vent and combustion air adapters to verify there are no obstructions or packing material inside the adapters and the gaskets are in place.
3. Ensure the adapter banding strap is loose prior to inserting the piping.
4. Apply a small amount of silicon grease or water to the insertion end of the pipe to ease insertion into the adapter.
5. Insert the pipe into the adapter until it is fully seated.

WARNING

Do not apply excessive force, twist or bend the adapter or vent / combustion air pipe when inserting. The adapter gasket could be damaged resulting in possible flue gas leakage.

6. Secure the vent or combustion air pipe by tightening the adapter banding strap. Do not over tighten the strap as the seal is made with gasket inside the adapter.

Vent and Combustion Air Piping Installation Guidelines

1. The installer should install the vent / combustion air piping working from the boiler to the piping termination. The piping should not exceed the lengths given in Table 1 page 3 for either the vent or combustion air.
2. The installer should cut the pipe to the required length and deburr the inside and outside of both ends.
3. The installer should chamfer the outside of the pipe ends to allow even distribution of cement when joining.

4. The installer should dry assemble the vent system prior to assembling any joints to ensure proper fit.
5. The pipe ends and fittings should be cleaned and dried thoroughly prior to assembly of the joint.
6. When assembling a joint the installer should:
 - a. Handle fittings and pipes carefully to prevent contamination of surfaces
 - b. Apply a liberal amount of primer to both surfaces - the end of the pipe and the insert socket of the fitting.
 - c. Apply a light uniform coating of approved cement to both surfaces - the end of the pipe and the insert socket of the fitting, while the primer is still wet.
 - d. A second coat of approved cement should be applied to the mating surfaces. The installer should avoid, however, using too much cement on the socket of the fitting to prevent a buildup of cement on the inside.
 - e. With the cement still wet, the pipe end should be inserted into the socket of the fitting and twisted 1/4 of a full turn. Ensure the pipe end is inserted fully into the socket of the fitting.
 - f. Any excess cement should be wiped clean from the joint. Inspect the joint to ensure a smooth bead of cement is noticed around the entire joint seam.
7. The installer should use perforated metal strap hangers or equivalent pipe hangers suitable for plastic pipe to support the piping. The hangers must be spaced at a maximum of every 5 feet of horizontal and vertical run of piping. A support must be placed near the boiler and every change in direction vertical or horizontal (i.e elbow). Do not penetrate any part of the piping or vent system with fastener.

NOTICE

Pipe hangers should not be tightly clamped to pipe to allow for thermal expansion/contraction movement. Pipe clamps or hangers should not contain any sharp edges which can damage the pipe

8. The vent should be sloped continuously from the termination back to the boiler with at least 1/4" drop per foot of run. Do not allow any sags in the run of piping.

WARNING

Do not pitch the vent downward away from the boiler. Potential condensate damage to the building exterior or to the surrounding landscape and/or potential risks of icing and blockage of the vent piping could occur.

9. Maintain a minimum clearance of 1/4" between the vent pipe and all materials, combustible or non-combustible. The installer must seal any wall, floor or ceiling penetrations as per local code requirements.

NOTICE

Do not insulate any vent pipes runs that pass through uncondition areas.

SECTION IV - COMMONWEALTH OF MASSACHUSETTS

Installations with the Direct Vent Termination Elevation At or Below 4 feet of Grade:

NOTICE

The following instructions apply to the installation of a direct vented appliance whose vent termination and combustion air inlet are installed at or below a four foot elevation (above the grade).

1. If not already present in the structure of the building, a carbon monoxide detector and alarm must be installed in the living area outside the bedroom(s). The carbon monoxide detector and alarm is provided by the installer.

NOTICE

The carbon monoxide detector and alarm installed in the living space outside the bedrooms shall comply with NFPA 720 (2005 edition).

2. A carbon monoxide detector and alarm shall be installed in the mechanical room in which the direct vent appliance is located. The carbon monoxide detector and alarm shall:
 - Be installed on the same 120 volt service circuit as the appliance such that only one service switch services both the appliance and the carbon monoxide detector.
 - Provide battery back-up power in case of power failure

NOTICE

The carbon monoxide detector and alarm installed within the same room as the direct vent appliance must meet ANSI/UL 2034 standards and comply with NFPA 720 (2005 edition). The carbon monoxide detector and alarm must be tested, approved and listed with a Nationally Recognized Testing Lab as recognized under 527 cm.

3. The direct vent termination must be approved for the appliance and when applicable the combustion air inlet must be approved for the appliance. Installation of the vent termination and combustion air inlet shall be in strict compliance with the installation instructions provided with the appliance.

NOTICE

The installer must leave the appliance installation manual and any documentation regarding the installation of the venting, vent termination and combustion air inlet with the appliance upon completion of the installation.

4. A metal or plastic identification plate (provided by the installer) must be mounted on the exterior wall of the building 4 feet directly above the location of the vent termination and combustion air inlet. The identification plate shall read **“Gas Vent Directly Below”**. The size of the plate and lettering shall be of sufficient size to be easily read from a distance of 8 feet.

Installations with the Direct Vent Termination Elevation Above 4 feet of Grade:

NOTICE

The following instructions apply to the installation of a direct vented appliance whose vent termination and combustion air inlet are installed above a four foot elevation above the grade.

1. If not already present in the structure of the building, a carbon monoxide detector and alarm must be installed in the living area outside the bedroom(s). The carbon monoxide detector and alarm is provided by the installer.

NOTICE

The carbon monoxide detector and alarm installed in the living space outside the bedrooms must comply with NFPA 720 (2005 edition).

2. A carbon monoxide detector and alarm shall be installed in the mechanical room in which the direct vent appliance is located. The carbon monoxide detector and alarm shall:
 - Be either hard wired or battery powered or both

NOTICE

The carbon monoxide detector and alarm installed within the same room as the direct vent appliance must comply with NFPA 720 (2005 edition).

3. The direct vent termination must be approved for the appliance and when applicable the combustion air inlet must be approved for the appliance. Installation of the vent termination and combustion air inlet shall be in strict compliance with the installation instructions provided with the appliance.

NOTICE

The installer must leave the appliance installation manual and any documentation regarding the installation of the venting, vent termination and combustion air inlet with the appliance upon completion of the installation.

Additional quality water heating equipment available from Triangle Tube

SMART INDIRECT FIRED WATER HEATERS



- Exclusive Tank-in-Tank design
- Stainless steel construction
- Available in 8 sizes and 2 models
- Limited LIFETIME residential warranty
- 15 year limited commercial warranty
- Self cleaning/self descaling design

TTP BRAZED PLATE HEAT EXCHANGERS

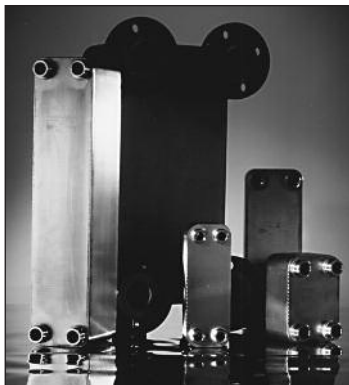

- For domestic water, snow melting, radiant floor, refrigeration
- Plates made of stainless steel, with 99.9 % copper and brazing, ensuring a high resistance to corrosion
- Self cleaning and self descaling
- Computerized sizing available from Triangle Tube/Phase III
- Available in capacities from 25,000 BTU/hr to 5,000,000 BTU/hr

PRESTIGE CONCENTRIC VENT KIT

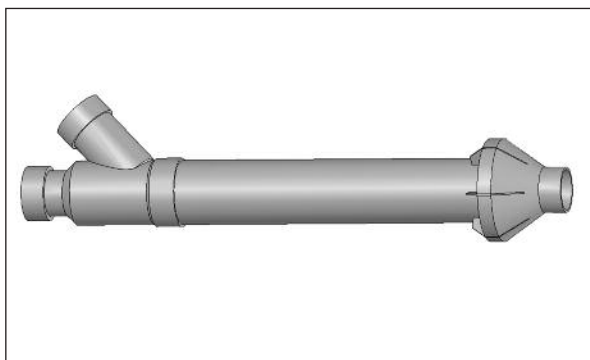

PRESTIGE DIRECT VENT SIDE WALL TERMINATION KIT

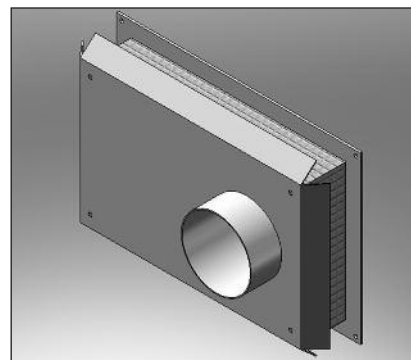

Freeway Center - 1 Triangle Lane - Blackwood, NJ 08012
Tel: (856) 228 8881 - Fax: (856) 228 3584
E-mail: Sales@triangletube.com

Member of

