



A thermostatic valve can only be as accurate as the temperature sensing bulb contained within the valve head. For this reason, OVENTROP uses a high quality liquid sensing bulb in its commercial thermostatic radiator valve heads.

The sensor is composed of a metal sensing bulb filled with a liquid which expands and contracts in response to the ambient temperature. The sensor is connected to a bellows with an internal plunger which opens or closes the radiator valve body. As room temperature falls, the bellows contracts and opens the valve seat. As the room temperature climbs, the bellows expands and closes the valve seat.

What are the advantages of an OVENTROP thermostatic valve?

- The sensor, because of its large volume, guarantees rapid and accurate response to changes in ambient temperatures.
- Wide temperature control range capabilities of 40 °F to 85 °F.
- Automatic "freeze protection" and shut-off-protection.
- The specially designed valve head with its air circulation feature and long isolation stem prevents interference by the flow medium temperature.
- The head is securely fastened to the valve body through its unique holding nut design which prevents any loosening problems.
- Wide range of thermostatic heads suitable for all applications (see next page).
- Lock-shield ring or protection cap prevents theft of or damage to the thermostatic head.
- All the thermostatic valve heads of the "UNI-SERIES" can be installed on any of the OVENTROP valve bodies.

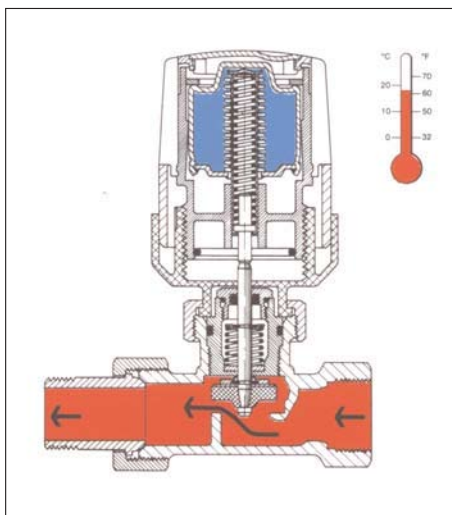
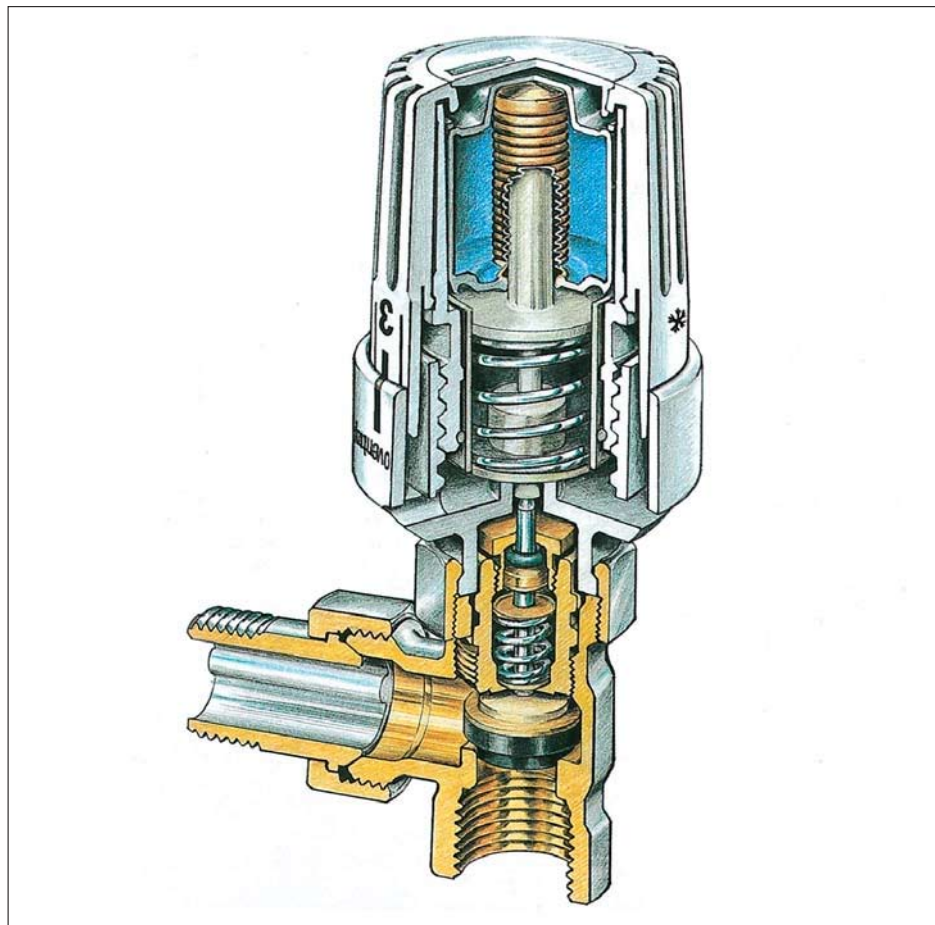

As room temperature falls, the bellows contracts and opens the valve seat.

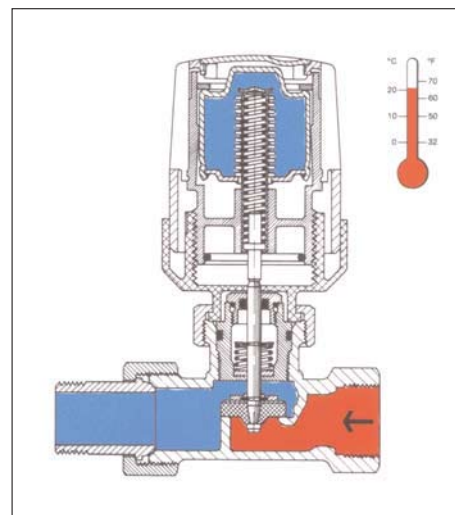

As room temperature climbs, the bellows expands and closes the valve seat.



"Uni XH" thermostat with internal sensor is used when the room air can pass freely over the sensor, Item no. 101 13 65.



"Uni LD" thermostat with remote capillary sensor (length 2 to 33 feet), Item no. 101 16 85.



Remote sensing and adjusting unit for the control of inaccessible valves, Item no. 101 22 95.



"Uni LH" thermostat with liquid sensor, Item no. 101 14 65.



"Vindo TH" thermostat with liquid sensor, Item no. 101 30 66



"Uni XH" thermostat with remote capillary sensor (length 2 to 33 feet), Item no. 101 15 65.

OVENTROP thermostatic valves need no external power—they maintain the room temperature by controlling the volume of hot water or steam flow.

The valve body is made of non-corrosive nickel-plated bronze. The valve stem and spring are made of stainless steel. The valve disc and "O"-ring are made of high temperature EPDM.

The valves are available in angle and straight patterns, reversed angle and side angle patterns, and in a variety of special patterns designed for specific applications.

The OVENTROP valve cartridge can be exchanged while valves are installed and the system is under pressure by using the specially designed "Demo-Bloc" tool available from OVENTROP for this purpose. By using this tool the valve cartridge can be replaced without having to drain the system.

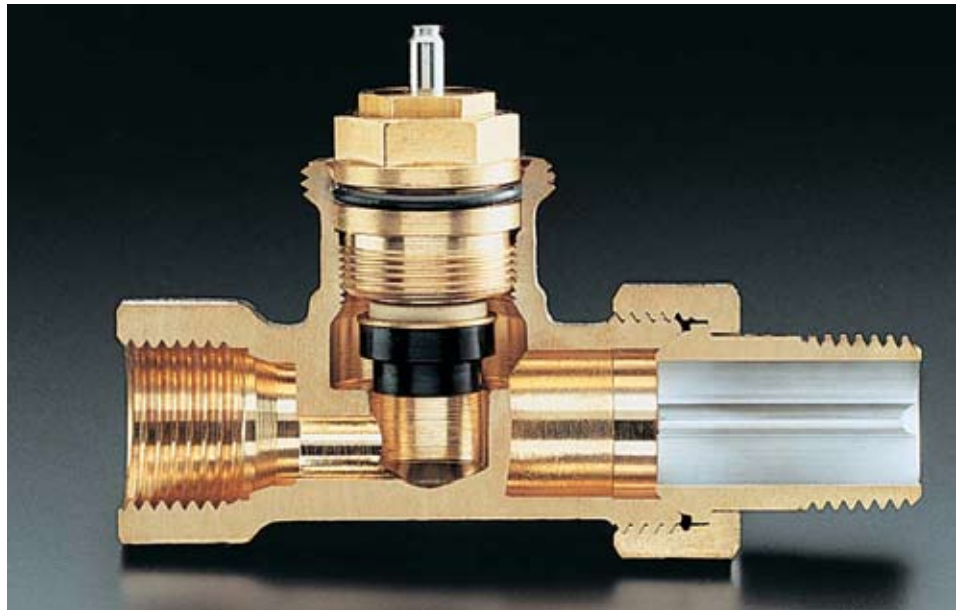

Radiator valve "Series A", straight pattern valve, Item no. 188 91 06

Applications

For one- and two-pipe central heating systems. Suitable for both forced hot water and steam applications.

Advantages of OVENTROP valve bodies

- special valve body design
- prevents flow noises and provides optimized CV values.
- the "O"-ring gland is replaceable under system pressure.
- the valve cartridge can be replaced without draining the system by means of "Demo-Bloc" tool.

Technical data

Max. working pressure	150 psig (10 bar)
Max. differential pressure	15 psig (1.0 bar)
Max. temperature	250° F (120° C)
for short period	max. 285° F (140° C)
Low pressure steam	max. 15 psig (1,0 bar) 230° F (110° C)



"Uni SH" thermostat, Item no. 101 20 65.



Room Thermostat, 24 V, Item no. 115 21 51.



Electrothermal actuator, normally closed, 24 V, Item no. 101 24 86



One pipe radiator injection valves with constant bypass and shut off, Item no. 118 35 61.

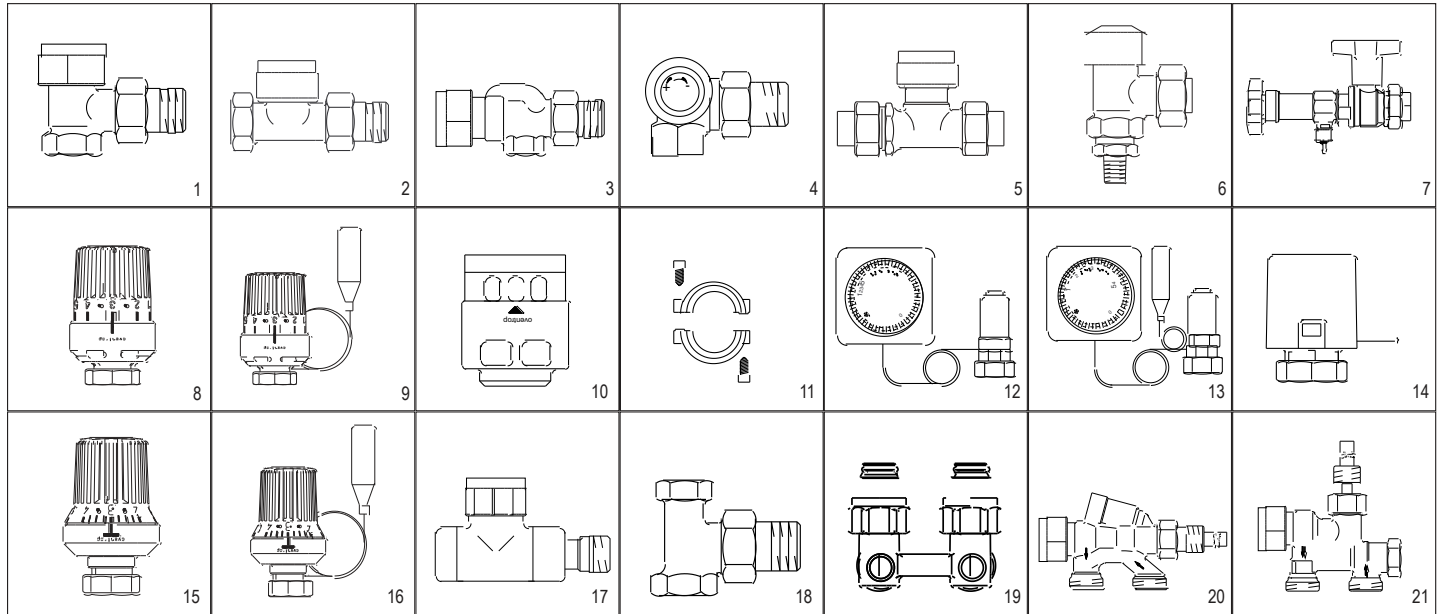

Type	Size	Item no.	Remarks
1 Angle pattern valve	1/2" NPT	188 90 04	with NPT tailpiece and internal NPT thread
	3/4" NPT	188 90 06	
	1" NPT	188 90 08	
	1-1/4" NPT	188 90 10	
2 Straight pattern valve	1/2" NPT	188 91 04	with NPT tailpiece and internal NPT thread
	3/4" NPT	188 91 06	
	1" NPT	188 91 08	
	1-1/4" NPT	188 91 10	
3 Reversed angle pattern valve	1/2" NPT	188 92 04	with NPT tailpiece and internal NPT thread
	3/4" NPT	188 92 06	
4 Side angle pattern valve	1/2" NPT left	169 40 62	with NPT tailpiece and internal NPT thread
	1/2" NPT right	169 40 63	
5 Straight pattern valve	1/2" CxC (solder)	169 44 14	with soldering connection
	3/4" CxC (solder)	169 44 16	
6 Angle pattern valve	1/8" NPT	188 83 51	for one-pipe steam system with special adapters
7 "Demo-bloc"	for all valves	118 80 51	for replacement of cartridges
8 Thermostat "Uni L" with built-in sensor	with "shut-off" position	101 14 65	liquid sensor
	without "shut-off" position	101 14 64	
9 Thermostat "Uni L" with remote sensor	with "shut-off" position	101 16 65	capillary length 2 to 33 feet
	without "shut-off" position	101 16 82	
10 Protection cap		101 18 65	impact resistant
11 Lock-shield ring		101 17 66	
12 Remote transmission	6.5 feet	101 22 95	for control of radiators with cabinet enclosures
	16 feet	101 22 96	
	33 feet	101 22 97	

Type	Size	Item no.	Remarks
13 Remote control	6.5 feet	101 23 95	with remote sensor
	16 feet	101 23 96	
14 Electrothermal actuator		101 24 86	24 V normally closed
15 Thermostat "Uni XH" with built-in sensor	with "shut-off" position	101 13 65	liquid sensor
16 Thermostat "Uni XH" with remote sensor	with "shut-off" position	101 15 65	6.5 feet
		101 15 66	
17 Straight pattern valve	1/2" BSP	116 31 52	chrome plated
	1/2" BSP	116 31 62	
18 Angle pattern service valve	1/2" NPT	109 10 82	
19 2-pipe isolating valve,	1/2" angle	101 58 14	
20 1-pipe radiator injection valve / conversion with horizontal insertion tube		118 35 61	with constant bypass and shut off
21 1-pipe radiator injection valve / conversion with vertical insertion tube		118 35 71	with constant bypass and shut off



Main factory in Olsberg



Production facility in Brilon



Olsberg in the "Hochsauerland" region

The OVENTROP company was founded in 1851 and has always been a family-owned business.

OVENTROP has a highly skilled, qualified and motivated workforce. Education and advanced training are an important precondition for entrepreneurial success. The company plays an important economic role in the region of its location. Job security for the workforce and protection of the environment are given top priority. OVENTROP is one of the leading European manufacturers of valves and controls for the building services industry.

OVENTROP offers its partners a long-term beneficial relationship.

The raw materials are produced for the foundry and presses, then further processing is done by using modern, computer programmed machines.

The assembly of the final product is also an automatic process.

The products are distributed all over the world by subsidiaries in Europe, the United States, and representatives in other important countries.

Oventrop Corporation

P.O. Box 789

29 Kripes Road

East Granby, CT 06026

Telephone: (860)413-9173

Fax: (860)413-9436

www.oventrop-na.net