



SUPERstor SOLAR

STAINLESS STEEL SOLAR WATER HEATER

- *Installation*
- *Operation*
- *Maintenance*



SB SERIES
WITH BACK-UP
HEAT EXCHANGER

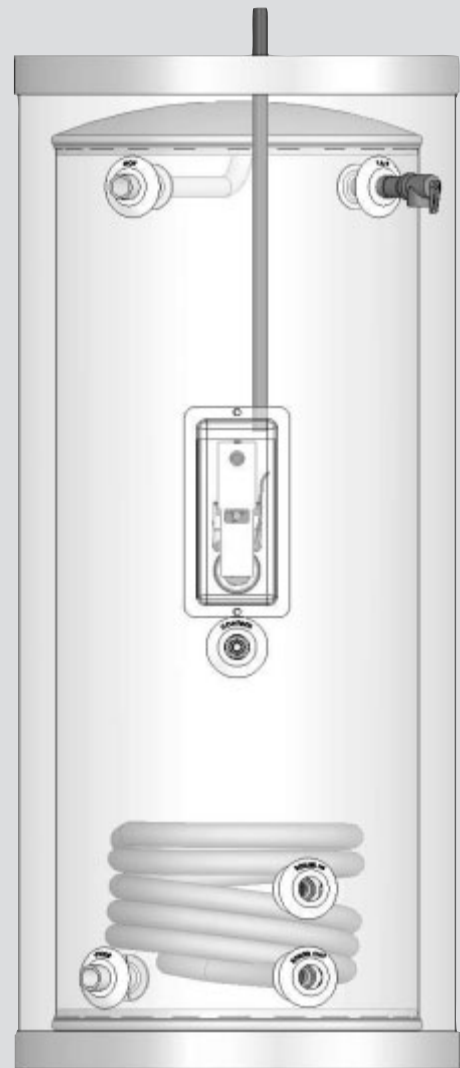

SE SERIES
WITH BACK-UP
ELECTRIC ELEMENT

The solar energy system described in this manual, when properly installed and maintained, meets the minimum standards established by the SRCC. This certification does not imply endorsement or warranty of this product by SRCC.

CONTENTS

Part 1 – Product and Safety Information	2-3
Definitions	
Local Installation Regulation	
Water Temperature Adjustment	
Part 2 – General Information	3-7
Preface	
Introduction	
System Description	
Specifications	
General Solar Panel Orientation	
General Solar Panel Installation	
Collector Loop Pipe Insulation	
Collector Piping	
Collector Sensor Placement	
Part 3 – Solar Water Heater Installation	7-19
Installation Check List	
Solar Water Heater Location	
Inspection of the SuperStor Solar Water Heater	
Potable Water Piping	
Solar Heat Exchanger Piping	
Tank Sensor Placement	
Solar Heat Exchanger Piping to Collector Panel	
Boiler Back-Up Heat Exchanger Connection	
Boiler Tank Control	
Circulator Sizing	
Boiler Back-Up Heat Exchanger (SB Models only)	
Electrical Connection	
Thermostat Adjustment	
Combination “Thermostat and High Limit Control (ECO)”	
Charging the System	
Commissioning the System	
Part 4 – Maintenance	20-25
Shut Down Procedures	
Vacation Shut Down	
Estimated Life of Components	
Part 5 – Troubleshooting	26-30

NOTICE

Heat Transfer Products, Inc., reserves the right to make product changes or updates without notice and will not be held liable for typographical errors in literature.

PART 1: PRODUCT AND SAFETY INFORMATION

Be sure to read and understand this entire manual before attempting to install and operate your water heater. Pay particular attention to the **Special Attention Boxes** located throughout this manual which will alert the user of a hazard. Failure to follow these warnings could result in serious bodily injury or death. Should you have a problem understanding the instructions in this manual or have any questions, **STOP**, and get help from a qualified installer, service technician, local electric utility or supplier.

SPECIAL ATTENTION BOXES

The following defined terms are used throughout this manual to bring attention to the presence of hazards of various risk levels or to important information concerning this product.

DEFINITIONS

⚠ DANGER

DANGER indicates an imminently hazardous situation which, if not avoided, will result in death or serious injury.

⚠ CAUTION

CAUTION Indicates a potentially hazardous situation which, if not avoided, may result in minor or moderate injury.

⚠ WARNING

WARNING indicates a potentially hazardous situation which, if not avoided, could result in death or serious injury.

CAUTION

CAUTION used without the safety alert symbol indicates a potentially hazardous situation which, if not avoided, may result in property damage.

LOCAL INSTALLATION REGULATION

Installation of the SuperStor Solar Water Heater may be governed by individual local rules and regulations for this type of product, which must be observed. Always use the latest edition of codes. The installation, adjustment, service and maintenance of the SuperStor Solar Water Heater must be done by a licensed professional who is qualified and experienced in the installation, service and maintenance of solar hot water systems.

NOTE: The system design of the SuperStor Solar system is approved by the Solar Rating and Certification Corporation (SRCC). Any deviation from the approved specified SRCC components for this design may affect your ability to certify this system.

⚠ DANGER

⚠ DANGER



Water temperature over 125 degrees F. can cause severe burns instantly, or death from scalds. Children, disabled, and elderly are at highest risk of being scalded. See instruction manual before setting temperature at water heater. Feel water before bathing or showering! Temperature limiting valves are available.

⚠ DANGER



WATER TEMPERATURE ADJUSTMENT

If the SuperStor Solar Water Heater is going to have a set temperature above 120 F you must use a rated anti-scald device to avoid severe burns or death from scalding temperature.

PART 1: PRODUCT AND SAFETY INFORMATION (CONT'D)

⚠ WARNING

Households with small children, disabled, or elderly persons may require a 120°F or lower temperature setting to prevent scalding with of hot water.

PART 2: GENERAL INFORMATION

PREFACE

The SuperStor Solar Hot Water Heating System will help to reduce the nation's dependence on polluting fossil fuels. Designed to meet the certification requirements of SRCC-0G-300, The SuperStor Solar is reliable, with a system performance that runs efficiently based on your specific region in the country.

INTRODUCTION

The System performance varies as a function of the household hot water load. The ambient air temperature, the roof pitch and orientation along with seasonal intensity will determine the efficiency of your SuperStor Solar System.

Your SuperStor Solar System uses a circulation pump that circulates the propylene glycol heat transfer fluid throughout the system. This fluid protects the collector piping from freezing and keeps scale deposits from forming that could reduce the performance of the system. Proper maintenance of the propylene glycol in the system can protect the solar water heating system to minus 60° Fahrenheit.

This manual is intended to familiarize you with the proper installation and maintenance of your SuperStor Solar Water Heater System. This system must be installed by a licensed solar or plumbing contractor in accordance with SRCC Standard OG-300 and all applicable national, state and local codes. Failure to follow the procedures described in this manual can void the manufactures' warranty.

SYSTEM DESCRIPTION

The system components required in the SuperStor Solar Water Heating System include the solar collector, The SuperStor Solar Tank, circulator pump, differential solar control, expansion tank, pressure gauge, mixing valve and non-toxic propylene glycol heat transfer fluid.

The solar collector is the engine of the SuperStor Solar System. When the sun is shining, the heat energy is absorbed by the solar collector and transferred to the HTF (Heat Transfer Fluid) circulating through the solar collector. The system pump efficiently circulates this heated fluid through the collector's piping and heat exchanger. As the HTF passes through the heat exchanger, the heat in the fluid is transferred by conduction to the potable water in your solar storage tank. This process is continuously repeated during the average sunny day as the temperature rises.

SPECIFICATIONS

This solar water heater is designed for the production of domestic hot water from either a solar collector, an electrical or boiler back up. The solar heat exchanger shall be located on the bottom section of the tank to heat the entire water volume of the tank. The electrical or boiler back up shall be located in the upper portion of the tank to provide back up heat if the solar collector is not providing enough heat to maintain the upper operating set point of the tank. This solar tank shall be equipped with a control well located a third of the way from the bottom of the tank located near the

PART 2: GENERAL INFORMATION (CONT'D)

coil to monitor the heat input, this is the best location for a water heater with a differential temperature controller.

The system components should carry temperature and pressure ratings equivalent to the design of the solar collector. The ratings for the solar collectors should be verified against the solar collector manufacturer's specifications, depending on the climate where the system is installed. The system temperatures for the collector and storage tank can be read from the system controllers. Typical tank operating temperatures can range from the cold supply of 40°-80°F up to 175°F, which represents the high limit of the tank. This will vary depending on the climate where the system is installed. The collector temperature sensor should be 5°-20°F above the tank sensor during normal charging operation. During idle periods, when there is no sun, the collector will read the ambient temperature and when there is full sun upward to 250°F. The system can be operated down to ambient temperatures of -60°F using proper concentrations of glycol. Freeze tolerance limits are based upon an assumed set of environmental conditions. Refer to the DOWFROST Specification sheet in the back of this manual for recommended concentrations.

The differential controller uses 10k ohm thermistors or 1k RTDs, depending on the controller model, to monitor the temperature difference between the collector and the SuperStor Solar Water Heater. The controller turns on when the collector is 12-20° F above tank temperature and turns off when the differential drops to 4°F.

GENERAL SOLAR PANEL ORIENTATION

Part of the performance of your solar water heater for optimal efficiency is based on the correct orientation of the solar panels. The collector should be mounted as close to the storage tank as possible to minimize heat loss in the piping runs. In North America, collectors should be oriented due south, however may be within 40-60 degrees of due south. Optimal tilt is +/- 10° from the latitude of the site. The solar collector must be located in an area of the roof that will be unshaded for the majority of the day (from 9:00-3:00) all year round. Adjacent buildings and trees should be checked for possible winter shading.

You must consult your solar panel installation manual for recommended mounting and positioning of the panels.

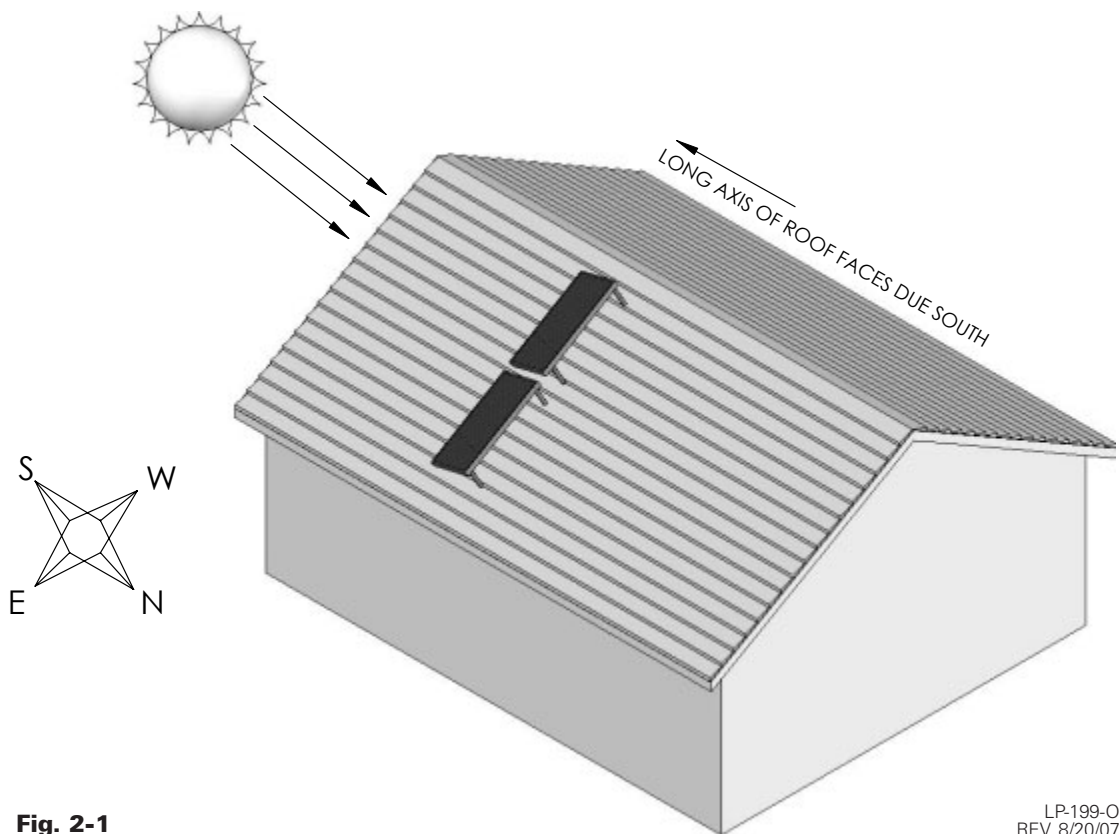

Fig. 2-1

LP-199-O
REV. 8/20/07

PART 2: GENERAL INFORMATION (CONT'D)

GENERAL SOLAR PANEL INSTALLATION

The Contractor shall obtain all required permits and approvals for installing the solar system. The installation shall conform to all federal, state and local regulations governing solar water heating system installations. The contractor shall adhere to sound building safety and trade practices. Special consideration must be given to building code requirements for the penetration of structural members and fire rated assemblies. Before the installation, the contractor shall inspect the condition of the roof and notify the homeowner of any existing roof damage or necessary repairs. The most important structural consideration is to securely anchor the solar collector and the solar strut mounting hardware to the structural members of the roof with stainless steel hanger or lag bolts as detailed in figures below. Consult with the panel manufactures installation manual for proper guidelines in your application. Preserving the integrity of the roof membrane is the most important roofing consideration. Ensure that all roof penetrations required to plumb and mount the solar collector are properly flashed and sealed in accordance with standard roofing practices. Tremco "POLYroof " is the recommended elastomer for sealing roof penetrations. Henry Co. 204, 208, or 209 mastic or Dow Corning Glazing Sealant are also acceptable.

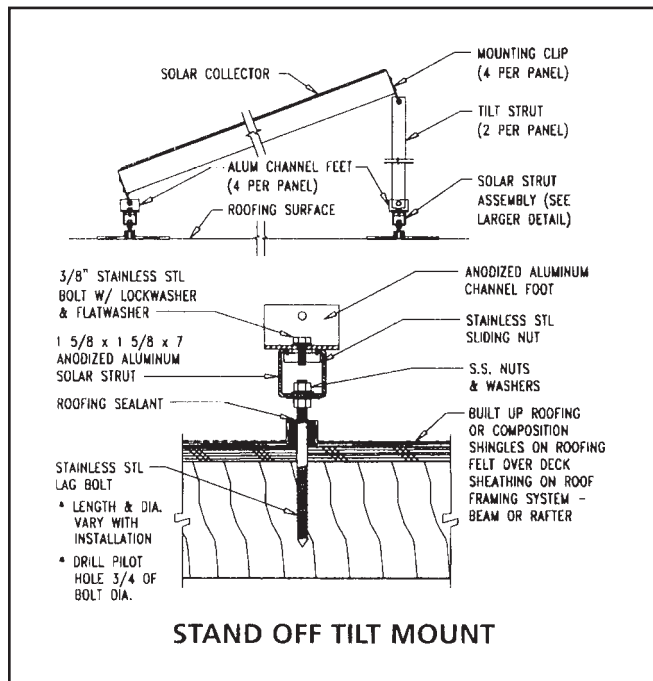
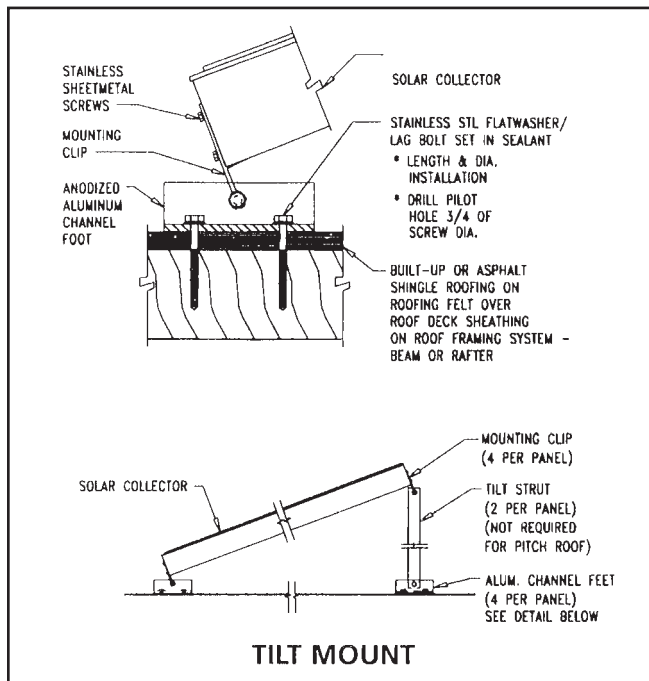

This detail is an example of a typical solar roof mount application. All equipment should be installed in accordance with all local codes and best practices as identified with National Roofing Contractors Association (NRCA) or other qualified body.

COLLECTOR LOOP PIPE INSULATION

The collector loop cold supply and hot return lines must be well insulated with a high quality flexible closed cell insulation to minimize heat loss. The wall thickness of the pipe insulation should not be less than 3/4". A 1" wall thickness is required in all areas prone to annual hard freeze conditions. When it comes to pipe insulation the rule is simple: thicker is better. The specified insulation material is Rubatex Insul-Tube 180 or equal.

To the extent possible, slide the insulation material over the pipe without cutting or taping. All butt joints must be sealed with contact adhesive. The use of rigid polyethylene pipe insulation is prohibited. The temperatures generated by your collector in the summer months or under stagnation conditions can melt this type of material.

PART 2: GENERAL INFORMATION (CONT'D)

Any above ground exterior pipe insulation is subject to UV degradation and must be wrapped with foil tape or painted with two coats of high quality water-based acrylic resin coating as supplied by the insulation manufacturer. Rubatex UV Protective Coating or equal is the required coating material.

COLLECTOR PIPING

⚠ CAUTION

NEVER USE DIELECTRIC UNIONS OF GALVANIZED STEEL FITTINGS ON ANY DOMESTIC WATER CONNECTIONS OF AUXILIARY CONNECTIONS. USE ONLY COPPER OR BRASS FITTINGS. TEFLON THREAD SEALANT MUST BE USED ON ALL CONNECTIONS.

Collector piping requires the use of all copper and brass fittings in the collector loop. Cast iron is also acceptable because it is a glycol loop. Couplings, rather than unions should be used to join the collectors to avoid leaks and fluid loss. Use only lead-free solder. Engelhard Silvacrite 100 or equal is required. Use of 50/50 lead solder is expressly prohibited. Use of galvanized steel, CPVC, PVC or any other type of plastic pipe is prohibited.

Piping in new solar installation may have dirt, grease, solder flux or other impurities that over time affect the quality of the glycol HTF. A thorough cleaning is required before charging the system with glycol.

All vertical piping between the storage tank and the collector shall be supported at each story or at maximum intervals of ten feet (10'). Copper plumbers tape or tube strap is required. The pipe insulation may not be compressed or crimped by the strapping material.

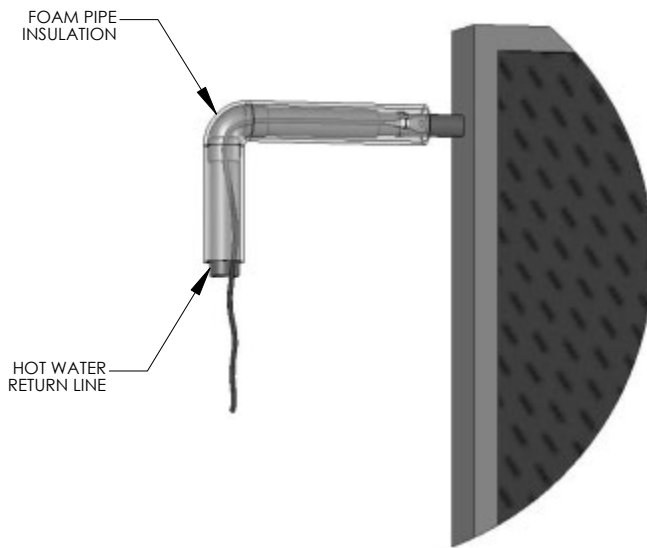

The installation of all horizontal and vertical piping may not reduce the performance or rating of any structural member or fire rated assembly. Adhere to all applicable local codes and ordinances.

COLLECTOR SENSOR PLACEMENT

The collector sensor must be located on the hot water return line as close to the collector as possible. Some collectors have insertion areas to measure temperatures more accurately at the collector manifold.

Sensors are typically accurate to +/- 1/2°F if properly installed and weatherized. To maximize sensor accuracy, attach the flanged portion of the sensor to the collector header pipe with a stainless steel hose clamp. Wire nuts used to connect the sensor and low voltage wiring shall be all plastic, sealed with silicone and thoroughly wrapped in electrician's tape.

Fig. 2-2

LP-199-O
REV. 8/21/07

The low voltage wiring used to connect the sensors to the controller should be a minimum 18 AWG. The wiring should be bare or tinned copper, two conductor, PVC insulated, with a PVC UV rated gray jacket suitable for exterior use. Use Eastman Wire & Cable no. 5704, Beldon Wire and Cable no. 8461 or equal.

The sensor "bundle" must be placed under the rubber pipe insulation covering the collector header.

PART 2: GENERAL INFORMATION (CONT'D)

Thoroughly wrap and weatherize the insulation with electrician's tape or insulation tape as provided by the manufacturer. (Rubatex Insul-Tape or equal).

PART 3: SOLAR WATER HEATER INSTALLATION

INSTALLATION CHECK LIST

Location:

- Sufficient room to service water heater
- Provisions made to protect area from water damage
- Centrally located to fixtures
- Protected from freezing temperatures
- Area free of flammable vapors

Potable Water Supply:

- All related piping is free from leaks.
- Thermal Expansion tank installed
- Water heater and fixtures have been properly purged of air.

Relief Valve:

- Temperature and Pressure Relief Valve properly installed and discharge line runs to open drain.
- Discharge line is not exposed to freezing temperatures.
- Discharge line is constructed of copper.

Wiring; SE Models:

- Power supply voltage agrees with the water heater rating plate.
- Branch circuit wire fusing or circuit breaker properly sized.
- Electrical connections tight and unit properly grounded.

Wiring; SB Models:

- Water heater control is secure in control well.
- Boiler back-up control is wired back to the boiler control or relay center.

Solar Heat Exchanger to Solar Panel; SE and SB Models:

- Anti-Freeze if required, is added and is rated as non-toxic with copy of MSDS sheet for homeowner.
- Solar Heat Exchanger is completely purged of air.
- Expansion tank and pressure temperature gauge are operating properly.
- Solar control shows circulators operating properly on the solar panels.

Boiler Heat Exchanger; SB Models Only:

- Heat Exchanger is completely purged of air.
- Expansion tank and pressure temperature gauge are operating properly.
- Boiler control is operating circulator for the boiler back-up heat exchanger.

Anti-Freeze Fluid:

- Make sure freeze protection fluids are certified as non-toxic.
- Glycol percentage must be calculated per local area freeze level.
- Provide glycol MSDS sheet to end user.

SOLAR WATER HEATER LOCATION

Choose a location for your solar water heater centralized to the piping system. You must also locate the SuperStor Solar Water Heater and related domestic piping where it will not be exposed to freezing temperature. All piping should be insulated. The Solar Water Heater should be installed so there is access to the element and thermostat for future service. If you do not provide minimum clearances, it might not be possible to service the water heater without removing it from the space. See

PART 3: SOLAR WATER HEATER INSTALLATION (CONT'D)

The solar water heater should also be placed in a location where T&P discharge or a leak will not result in damage to the surrounding area. If you do not have this location requirement available, you must use an auxiliary catch pan.

AUXILIARY CATCH PAN

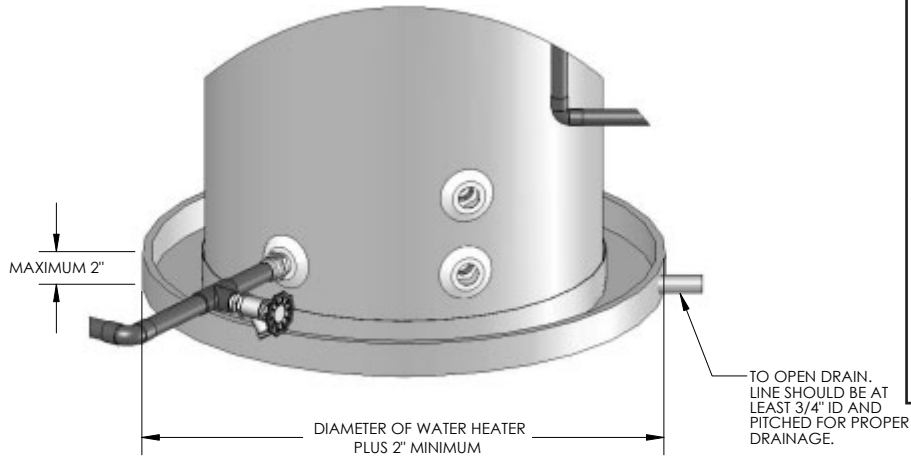

LP-199-J
REV. 6/14/07

RECOMMENDED SERVICE CLEARANCE

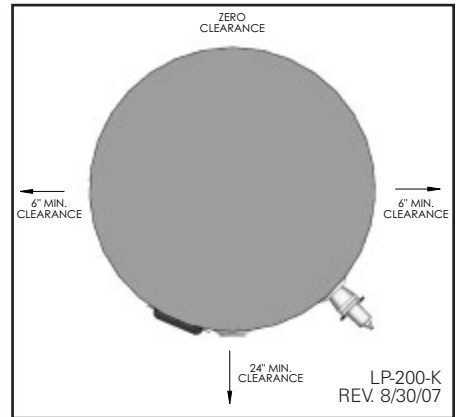

LP-200-K
REV. 8/30/07

INSPECTION OF THE SUPERSTOR SOLAR WATER HEATER

Inspect the SuperStor Solar Water Heater for possible damage. Check markings on the rating plate to be certain of the power supply (Solar Electric Only) corresponds to that for which the water heater is equipped.

POTABLE WATER PIPING

The design and installation of the SuperStor Solar Water Heating System should be done by qualified individuals. It is important that good design and installation practice be followed to assure that your system will operate properly. Failure to follow installation guidelines for your SuperStor Solar Water Heater System could cause component failure and possible safety issues.

It is mandatory that all plumbing be done in accordance with all local and state codes or warranty will be void. It is also necessary on all mechanical connections to use both thread tape and pipe dope. The potable water piping is located on the side of your SuperStor Solar Water Heater and marked Hot and Cold. It is recommended that unions or flexible copper connectors be used so heater can be easily serviced. Install a shut-off valve in the cold feed near the Solar Water Heater to isolate the tank for future service (See Figure 3-1).

⚠ WARNING

Do not introduce heat transfer fluids into any fittings on the heater except those clearly marked for that purpose and must be classified as non-toxic. See the HTF Specification in the back of this manual.

Provide clear access to the storage tank, pump, expansion tank, mixing valve, time clock and other key components. The components on the potable side of the system may require future service or maintenance, so it is recommended that the connections be made with brass unions. You must use copper and brass fittings in plumbing the solar storage tank and expansion tank. The use of galva-

PART 3: SOLAR WATER HEATER INSTALLATION (CONT'D)

nized fittings, nipples, di-electric unions, CPVC, PVC or other plastic pipe is prohibited.

Hard copper connections to the city cold water supply line and home hot water feed lines are recommended.

The gaskets in standard water heater flex hose connectors can become brittle and compressed over time and begin leaking on the water heater. If not detected in a timely manner, even a drip or leak may cause serious damage to the tank's electrical components or in extreme cases, may cause the tank to leak from the outside in.

POTABLE WATER HEATING SYSTEM

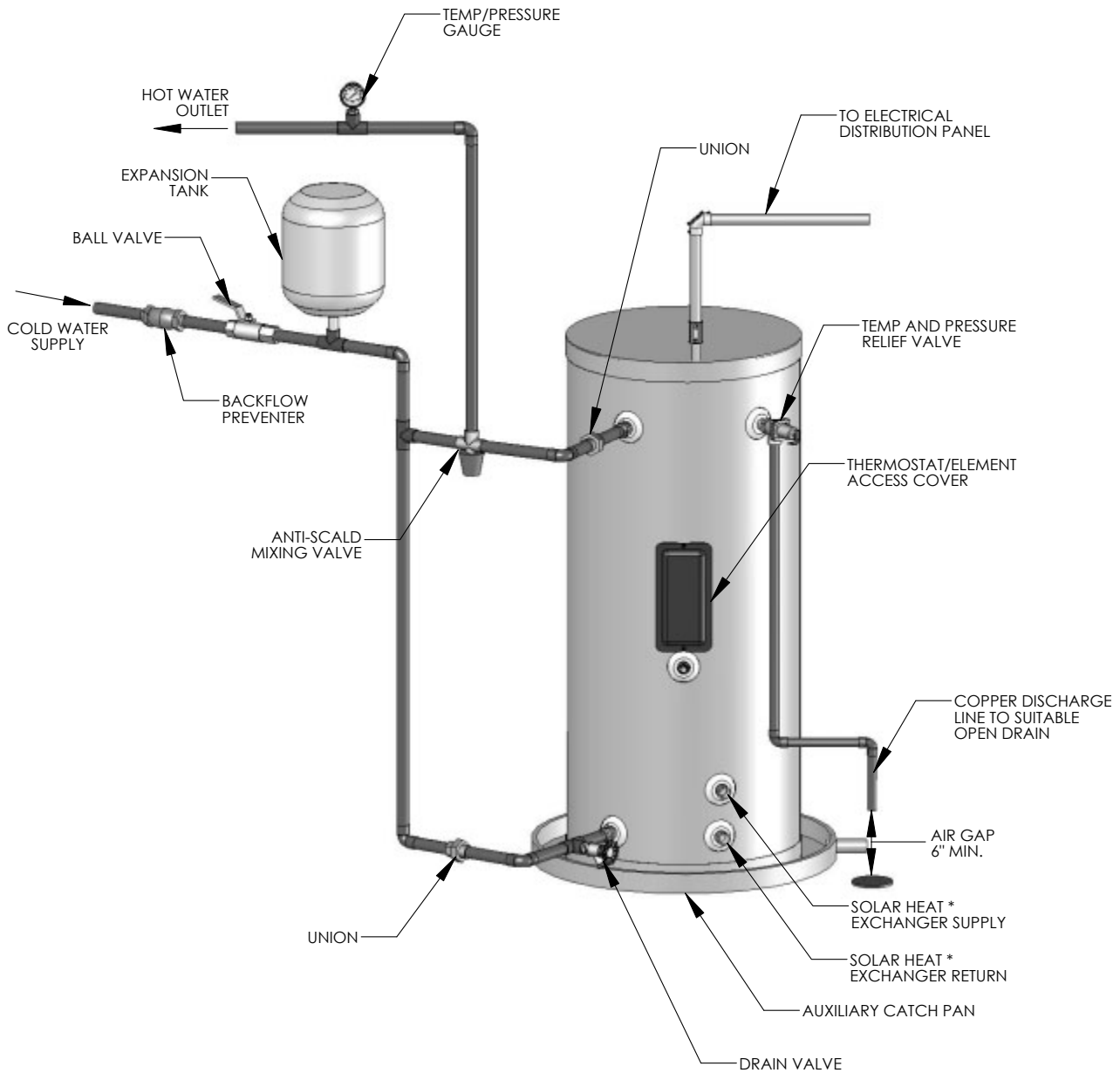

* THESE CONNECTONS ARE FOR NON-POTABLE HEAT TRANSFER FUIJD LOOP. DO NOT MAKE POTABLE WATER CONNECTIONS TO THESE FITTINGS. DO NOT INTRODUCE NON-POTABLE HEAT TRANSFER FLUIDS INTO ANY OTHER TANK FITTING.

Fig. 3-1

LP-199-N
REV. 8/24/07

PART 3: SOLAR WATER HEATER INSTALLATION (CONT'D)

SOLAR HEAT EXCHANGER PIPING

Set the primary balance of the system components down following the piping detail in this manual.

Run ½" type M or greater copper pipes to and from the collector following the direction or supports, penetrations and other relevant items.

Only copper, cast iron and brass are to be allowed in the collector piping loop due to transient operating temperatures that may reach as high as 300°F. PEX, PVC, CPVC and other polymers are expressly prohibited in the piping network.

When making a connection to the heat exchanger, use Teflon Tape and joint compound to prevent leaks. The connections to the heat exchanger are 1" NPT. Do not apply heat directly to the heat exchanger thread connection when sweating fittings.

Line pressure and temperature gauge shall be installed in the collector supply and return lines to allow for a simple diagnostic check of proper system operation. On a sunny day, the hot water return line should be approximately 5°-12° warmer than the water in the collector supply line. Compare the temperature readings in the two line thermometers. The ¾" cold water supply line to the SuperStor Solar Storage Tank must be insulated with a minimum 7/8" x 1/2" pipe insulation to a minimum distance of 5' behind the storage tank, or to the wall if closer than 5'.

TANK SENSOR PLACEMENT

Make sure the sensor is secured inside the well located in the lower section of the water heater. Secure the sensor by packing Rubatex insulation behind the sensor. This will also help the sensor react to temperature change.

Freeze protection fluid must be used to protect the system from freezing and must be rated as non-toxic. Use a mixture most appropriate for your climate. Do not use a higher glycol to water concentration than necessary, as this will adversely impact heat transfer efficiency. See the **DowFrost Data Sheet** in the back of this manual for recommended concentrations. A copy of the MSDS sheet must be left with the end user of the Solar System. See **"EMERGENCY OVERVIEW"** as part of the DowFrost Data Sheet in the back of this manual. The collector loop must be charged with a mixture of heat transfer fluid and distilled or deionized water. The use of regular tap water as a mixing agent is prohibited. Scheduled maintenance must be established to monitor and maintain the proper PH level of the heat transfer fluid in the system to protect the heat exchanger and other components in the system.

SOLAR HEAT EXCHANGER PIPING TO THE COLLECTOR PANEL

Listed below are the components needed for installation of the SuperStor Solar Water Heater.

1. Solar Collector

Absorbs the sun's energy and transfers this energy into the the heat exchanger located on the bottom of the SuperStor Solar Water Heater .

2. Solar Air Release Vent*

This air vent is used in the solar system to allow air contained in the system to be released.

The air vent valve must be designed to work in high temperatures(as high as 350°F) with a glycol medium. (This is typical of solar heating systems.)

3. Solar Collector Sensor

This sensor is to wired to the solar controller and automatically turns on the circulator pump when the differential set point is reached between the solar water heater and the solar collector.

***Remove and cap the solar air release vent after commissioning the system.**

PART 3: SOLAR WATER HEATER INSTALLATION (CONT'D)

4. Tank and Heat Exchanger Temperature and Pressure and Gauge.

The Temperature and Pressure Gauge on the solar piping will show the user the actual temperature and pressure being supply and returned to the solar collector.

5. Check Valve

The Check Valve helps minimize the convective heat loss at night when the system is not operating. If a check valve is not installed, most of the heated energy stored during the day would be transferred back up into panel and lost.

6. Collector Array Isolation Valve (Valve #6)

Valve #6 & 11 (for Solar Collector Isolation) to isolate the solar collector loop from the solar water heater.

7. Pressure Relief Valve (for Solar System Isolation)

Will release the pressure in the Solar Loop when it exceeds 150 PSI. If the valve opens and releases fluids, than it is recommend that you contact your contractor immediately.

8. System Fill Valve (Valve #8)

Used to fill the system with HTF fluid and also eliminate air form the system.

9. Expansion Tank

Pre-charged with air to allow for the expansion as the HTF fluid gets expansion and contraction with heating and cooling.

10. Drain Valve (Valve #10)

Used to charge the collector loop with glycol, purge air form loop and drain the Solar water heater heat exchanger of fluid.

11. Collector Array Isolation Valve (for system fill) (Valve #11)

When closed is used to direct the flow of the fluid to pressure the entire Solar system with HTF fluid and eliminate air from your Solar system.

12 Ball Valve (for circulator) (Valve #12)

Used Isolate the Circulator Pump for service. Close both ball valves to isolate pump.

13. Circulator (Valve #13)

Circulates the HTF fluid form the Solar Collector into the Super Stor Solar Exchanger.

14. Drain Valve (Tank) (Valve #14)

Used to flush sediment which may accumulate on the bottom of the Super Stor Solar Water Heater and also provide a means of draining the tank.

15. Tank Sensor

The Tank Sensor is wired to the solar controller to measure the temperature on the bottom of the SuperStor Solar Water Heater in conjunction with the solar collector sensor which will turn the circulating pump on and off at the solar control preset temperature differentials.

16. Solar Controller

The solar controller, turns on or off circulator depending on the heat gained from the solar operation. The controller will also limit over heating in the SuperStor Solar Water Heater. Some controllers have various options. The controller should always be set in the "auto" position so that it operates the array auomatically when there is solar energy to be collected.

PART 3: SOLAR WATER HEATER INSTALLATION (CONT'D)

17. Solar Heat Exchanger

The Solar Heat Exchanger is designed to transfer heated energy rapidly from the solar collector into the potable water. The Heat Exchanger has an integral finned tube design. The Heat Exchanger is constructed in 90/10 copper nickel for superior corrosion resistance and long term reliability.

18. Hot Water Outlet

Each SuperStor Solar Water Heaters has a hot water dip tube outlet which draws water from the very top of the heater. This helps to keep the heat trapped inside the highly insulated storage tank.

19. Temperature and Pressure Relief Valve

The Relief Valve must comply with standards for relief valves (ANSI Z21.22) by a nationally recognized lab that maintains periodic inspections of production listed equipment. No valve of any type should be installed between the relief valve and tank. Local codes govern installation of relief valves.

The outlet of the relief valve must be piped to suitable open drain so that the discharge water cannot contact live electric parts to eliminate potential damage. Piping used should be approved for hot water distribution. The valve discharge line must be no smaller than the outlet of the valve and must be pitched downward from the valve to allow complete drainage of the relief valve and discharge line. The end of the discharge piping should be not be threaded or concealed and should be protected from freezing. No valve of any type, restriction or reducer coupling should be installed in the discharge line.

20. Anti-Scald Mixing Valve

Automatically blends the hot water and the cold water feed line to control the discharge temperature to an acceptable and safe temperature. This will also increase the amount of hot water that is drawn from the SuperStor Solar Water by not allowing the incoming water to fully temper the hot water stored inside the tank.

21. Back-Up Electric Element with Thermostat (SE Model)

The back electric element will only be activated when the desired minimum set point temperature set on the back-up thermostat cannot be satisfied by the solar gain achieved from the solar collector.

22. Boiler Back-Up Heat Exchanger (SB Model)

The back-up boiler will only be activated when the desired minimum set point temperature set on the back-up thermostat can not be satisfied by the solar input from the solar collector.

23. Boiler Back Up Aquastat

The Boiler Back Up Aquastat will activate the boiler to circulate the hot water generated from the boiler into the Heat Exchanger located on the top section of the SuperStor Solar SB model. Once the controller is satisfied and has reached its desired set point, it will shut off the boiler. This Back-up portion will only be activated if the solar gain achieved from the solar collector can not keep the tank at the minimum desired temperature setting.

24. Ball valve (for cold water shut off) (Valve #24)

The cold water shut off valve should be used in the event of an emergency shut down.

CAUTION

It is very important that you do the potable piping before you pipe into your solar system. Failure to do so may damage your water heater.

PART 3: SOLAR WATER HEATER INSTALLATION (CONT'D)

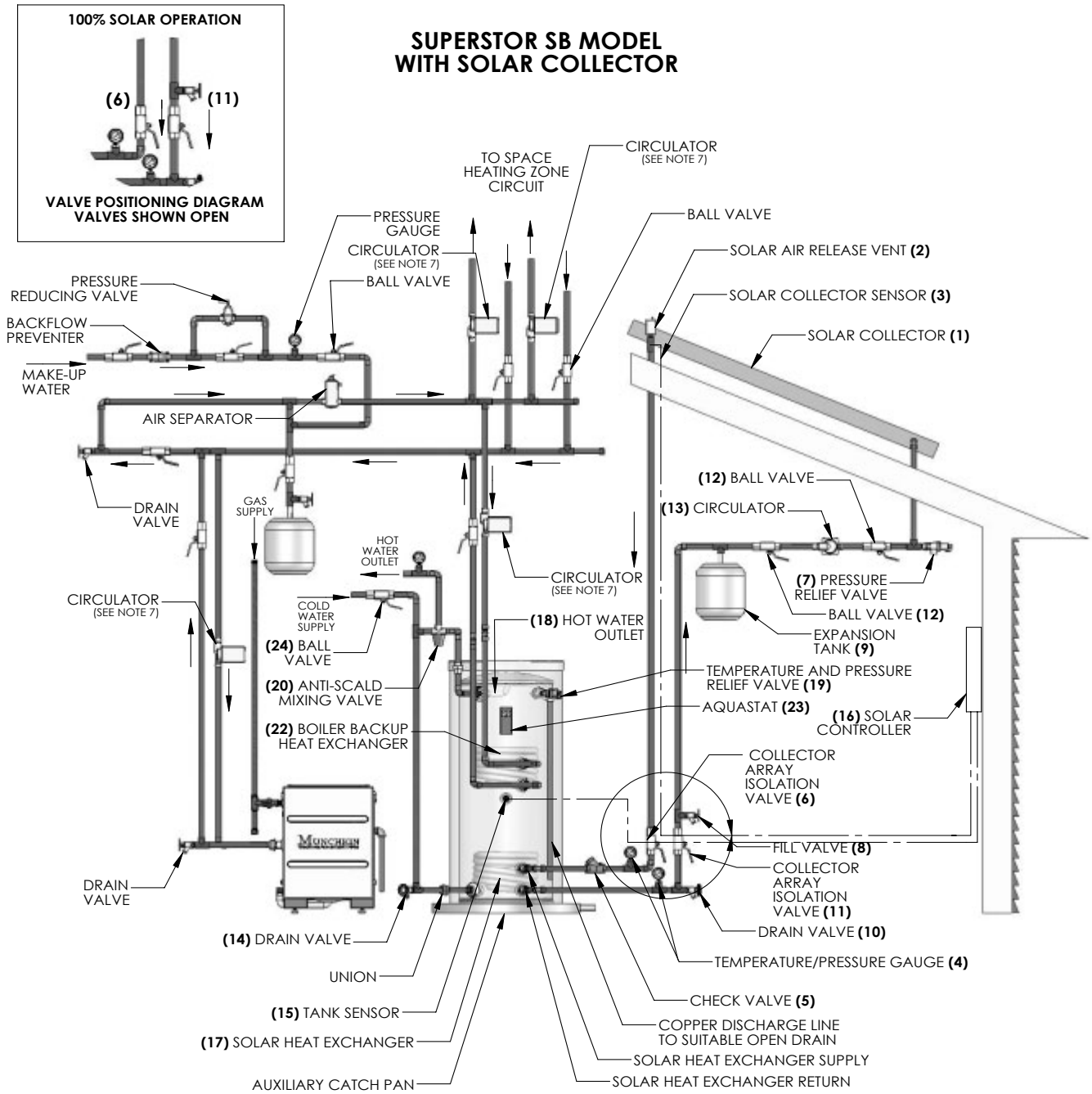

NOTES:

1. THIS DRAWING IS MEANT TO SHOW A SYSTEM PIPING CONCEPT ONLY. THE INSTALLER IS RESPONSIBLE FOR ALL EQUIPMENT AND DETAILING BY LOCAL CODES.
2. ANTI-FREEZE, NON- POTABLE HEAT TRANSFER FLUID SHALL BE USED FOR THE SOLAR HEAT EXCHANGER CIRCUIT ONLY. NEVER INTRODUCE ANTI-FREEZE SOLUTION TO ANY OTHER CONNECTION OTHER THAN THE SOLAR HEAT EXCHANGER.
3. IF THERE IS A CHECK VALVE ON THE COLD WATER FEED LINE, A THERMAL EXPANSION TANK SUITABLE FOR POTABLE WATER MUST BE SIZED AND INSTALLED WITHIN THIS PIPING SYSTEM BETWEEN THE CHECK VALVE AND THE COLD WATER INLET OF THE SOLAR WATER HEATER.
4. AN ANTI-SCALD MIXING VALVE IS RECOMMENDED IF THE DOMESTIC HOT WATER SETTING IS ABOVE 120F.
5. A MINIMUM OF 12 DIAMETERS OF STRAIGHT PIPE MUST BE INSTALLED UPSTREAM OF ALL CIRCULATORS.
6. **FOR ALL SE MODELS**, MAKE SURE TANK IS FULLY PURGED OF AIR BEFORE POWER IS TURNED ON TO THE BACKUP HEAT SOURCE.
7. CIRCULATORS SHOWN IN THE HYDRONIC BOILER PIPING ABOVE SHOULD HAVE AN INTEGRAL FLOW CHECK OR ALTERNATELY USE A STOCK PUMP WITH AN EXTERNAL SPRING TYPE CHECK VALVE. (CIRCULATORS WITH INTEGRAL FLOW CHECKS ARE NOT TO BE USED IN SOLAR SYSTEMS DUE TO EXTREME TEMPERATURES.)

Fig. 3-2

LP-199-B
REV. 10/18/07

PART 3: SOLAR WATER HEATER INSTALLATION (CONT'D)

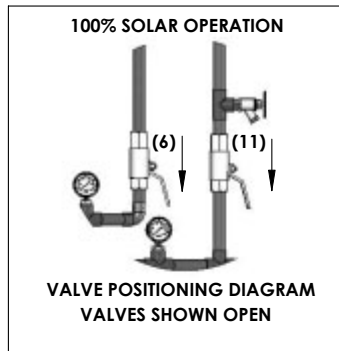

SUPERSTOR SE MODEL WITH SOLAR COLLECTOR

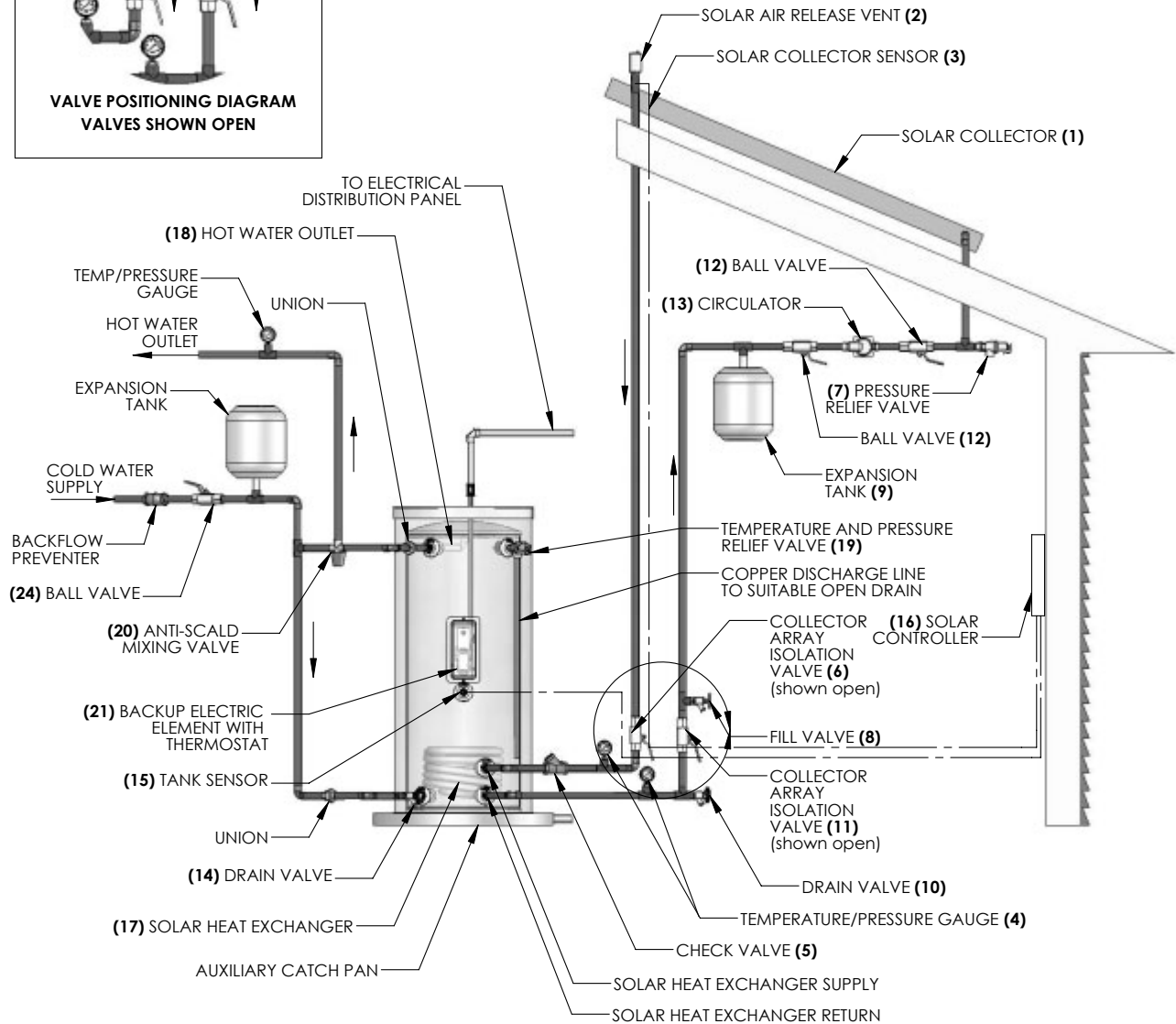

NOTES:

1. THIS DRAWING IS MEANT TO SHOW A SYSTEM PIPING CONCEPT ONLY. THE INSTALLER IS RESPONSIBLE FOR ALL EQUIPMENT AND DETAILING BY LOCAL CODES.
2. ANTI-FREEZE, NON- POTABLE HEAT TRANSFER FLUID SHALL BE USED FOR THE SOLAR HEAT EXCHANGER CIRCUIT ONLY. NEVER INTRODUCE ANTI-FREEZE SOLUTION TO ANY OTHER CONNECTION OTHER THAN THE SOLAR HEAT EXCHANGER.
3. IF THERE IS A CHECK VALVE ON THE COLD WATER FEED LINE, A THERMAL EXPANSION TANK SUITABLE FOR POTABLE WATER MUST BE SIZED AND INSTALLED WITHIN THIS PIPING SYSTEM BETWEEN THE CHECK VALVE AND THE COLD WATER INLET OF THE SOLAR WATER HEATER.
4. AN ANTI-SCALD MIXING VALVE IS RECOMMENDED IF THE DOMESTIC HOT WATER SETTING IS ABOVE 120F.
5. A MINIMUM OF 12 DIAMETERS OF STRAIGHT PIPE MUST BE INSTALLED UPSTREAM OF ALL CIRCULATORS.
6. **FOR ALL SE MODELS**, MAKE SURE TANK IS FULLY PURGED OF AIR BEFORE POWER IS TURNED ON TO BACKUP HEAT SOURCE.
7. CIRCULATORS SHOWN IN THE HYDRONIC BOILER PIPING ABOVE SHOULD HAVE AN INTEGRAL FLOW CHECK OR ALTERNATELY USE A STOCK PUMP WITH AN EXTERNAL SPRING TYPE CHECK VALVE. (CIRCULATORS WITH INTEGRAL FLOW CHECKS ARE NOT TO BE USED IN SOLAR SYSTEMS DUE TO EXTREME TEMPERATURES.)

Fig. 3-3

PART 3: SOLAR WATER HEATER INSTALLATION (CONT'D)

**BOILER BACK-UP HEAT EXCHANGER CONNECTION
(ULTRA SOLAR WATER HEATER WITH BOILER BACK UP ONLY – SB MODELS ONLY)**

The Boiler Heat Exchanger Connections are located in the front of the Solar Water Heater. Use a 1" nominal minimum tube size, wherever you are using zone valves or circulators.

The inlet of the circulator is to be connected to the hot outlet side of the boiler. Be sure the direction of the arrow on the circulator is facing toward the flow direction from the boiler to the boiler heat exchanger inlet of the water heater. On the water heater, the boiler return is to be connected to the return side of the boiler. The return from heating loop should have a flow check or swing check valve installed before the return pipe from the boiler heat exchanger.

BOILER TANK CONTROL

Insert the boiler tank control into the control well provided in the front of the water heater. Wire the boiler tank control to the boiler control or relay center. Additional equipment may be needed in order to wire the control to the existing system. Controls also have the ability to monitor and displaying solar collector temperature and also upper and lower tank temperature. See Control Installation Detail (Fig. 3-5).

SENSOR INSTALLATION

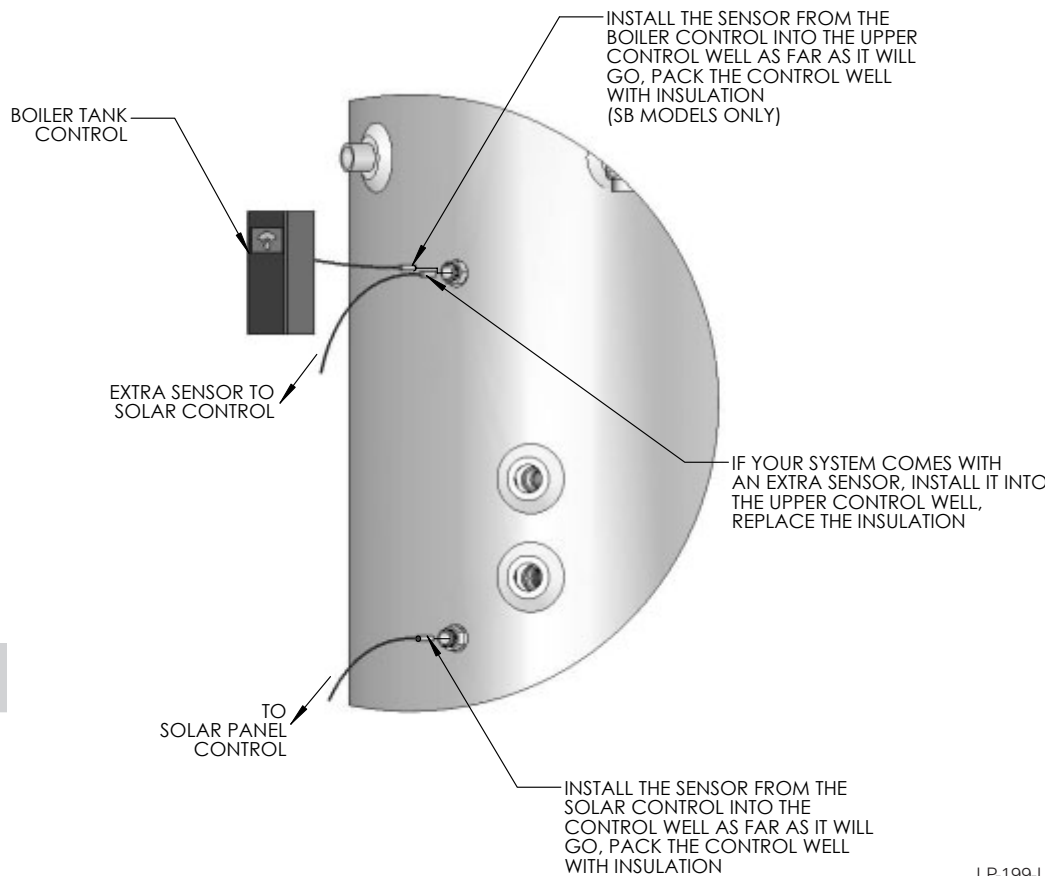

Fig. 3-4

LP-199-L
REV. 9/10/07

CIRCULATOR SIZING

The circulator pump must be sized for the related piping and pressure drop of the heat exchanger. The following graph represents the pressure drop of the solar heat exchanger. You must consult the solar panel manufacturer for flow requirements to assist in pump selection.

PART 3: SOLAR WATER HEATER INSTALLATION (CONT'D)

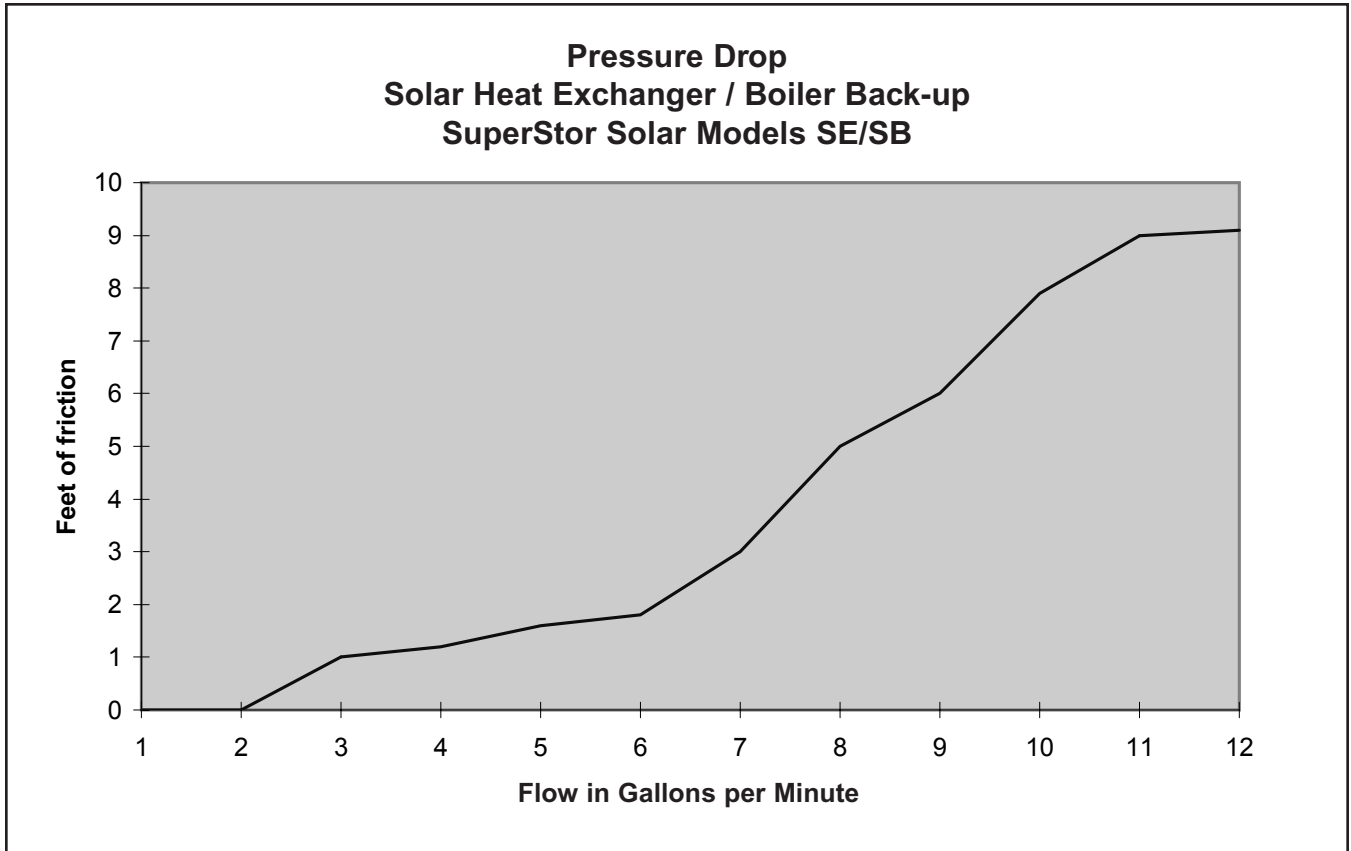

Fig. 3-5

LP-200-L
REV. 6/15/07

BOILER BACK-UP HEAT EXCHANGER (SB MODELS ONLY)

To assure that you have the correct flow through the Boiler Back-Up Heat Exchanger, refer to the chart above to size your circulator correctly to your boiler or auxiliary heat source. We recommend a flow rate of 1 gpm for every 10,000 BTU based on a 20 degree temperature difference between the supply and return of the Heat Exchanger.

Example: Boiler is 100,000 BTU output = $100,000 \text{ BTU} \div 10,000 \text{ BTU} = 10 \text{ gpm}$ flow rate. The Heat Exchanger at 10 gpm will require a circulator that will operate at 8 feet of friction.

PART 3: SOLAR WATER HEATER INSTALLATION (CONT'D)

ELECTRICAL CONNECTION

(SUPERSTOR SOLAR WATER HEATER WITH ELECTRIC BACK UP ONLY – SE MODELS ONLY)

⚠ WARNING

Tank must be full before unit is turned on! The Heating Element will be damaged if energized for even a short period time while tank is dry!

⚠ CAUTION

Be sure to ground the water heater. The preferred way to ground, is to use rigid metal conduit between the main panel and the water heater junction box with approved end fittings. The separate ground wire connection provided in the water heater junction box must also be grounded. Replace the junction box cover and insulation after you've made the all wiring connections.

The heating element in the SuperStor SE is wired to junction box inside of the jacket in the front of heater for 240 volt / 4500 watt A.C. The voltage requirement and wattage load for the heater is also specified on the heater identification plate. A 1/2" E.M.T. connector, located on top of the unit is provided for a field wiring connection. Consult an electrician to determine if your electrical service is adequate for the additional load of the heater. The electrical installation should be done by a qualified licensed electrician. All wiring must conform to the National Electric Code and per local codes.

⚠ CAUTION

The manufacturer's warranty does not cover any damage or defect caused by the installation, attachment or use of any type of unapproved devices into, onto or in conjunction with this water heater. The use of unauthorized energy saving devices may shorten the life of the water heater and may endanger life and property. The manufacturer disclaims any responsibility for such loss or injury resulting from the use of such unauthorized devices.

SUPERSTOR SE SERIES SOLAR WATER HEATER

**SINGLE ELEMENT
240 VOLT AC-4500 WATT ELEMENTS**

**#12 AWG WIRE
SUITABLE FOR
AT LEAST 75 DEGREES
IS TO BE USED.**

**COMBINATION THERMOSTAT
HIGH LIMIT CONTROL**

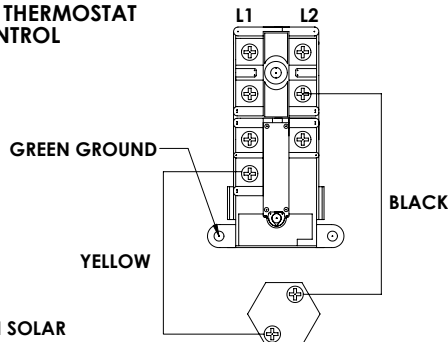

**BRANCH CIRCUIT
PROTECTION
MUST BE 20 AMPS ON SOLAR
SE MODELS**

Fig. 3-6

LP-200-C1
REV. 5/17/07

PART 3: SOLAR WATER HEATER INSTALLATION (CONT'D)

After the water and electrical connection have been made and the tank has been filled with water, turn on power to heater. The heater is now operational.

⚠ DANGER

⚠ DANGER



Water temperature over 125 degrees F. can cause severe burns instantly or death from scalds. Children, disabled, and elderly are at the highest risk of being scalded. See instruction manual before setting temperature at water the heater. Feel water before bathing or showering! Temperature limiting valves are available.

⚠ DANGER



THERMOSTAT ADJUSTMENT

The thermostat is located in the front of the heater. The access cover must be removed to adjust to the factory default setting of 119°F. This temperature is satisfactory for the average household use.

If an adjustment is necessary, turn off the power to the heater, remove the black access cover and insulation. The thermostat protective cover should not be removed. Set the temperature indicator to the desired temperature, replace insulation and access cover. Turn on power to heater.

COMBINATION "THERMOSTAT AND HIGH LIMIT CONTROL (ECO)"

This heater is equipped with a combination thermostat and high limit safety. If for any reason the water temperature becomes excessively high, the "High limit control (ECO)" breaks the circuit to the heating element. Once the switch opens, it must be reset manually. However, THE CAUSE OF THE OVER TEMPERATURE CONDITION MUST BE CORRECTED FIRST. REFER TO THE TROUBLE SHOOTING SECTION for possible causes. To reset, press the red reset button as shown in Figure 3-7. Replace the insulation and black access cover before turning on power to the heater.

CHARGING THE SYSTEM

Solar Tank

Fill the solar tank with water. Do this by opening the cold water isolation ball valve to the solar tank. See Fig. 3-1. Inspect all fittings for leaks. The solar collector loop should be pressure tested with air (25 lbs.) before you pressurize the solar collector loop with glycol. Mix the DowFrost Propylene glycol and distilled water in accordance with the DowFrost Data Sheet in the back of this manual. The charging process will require a low flow diaphragm pump to fill and pressurize the collector loop.

Solar Collector

Connect the discharge side of the pressure pump to the fill valve. See Fig. 3-2/3-3. Place the pump suction side hose in the glycol solution. Close the ball valve (#11). Connect a second hose to the drain valve (#10) and place the other end of the hose in the empty bucket.

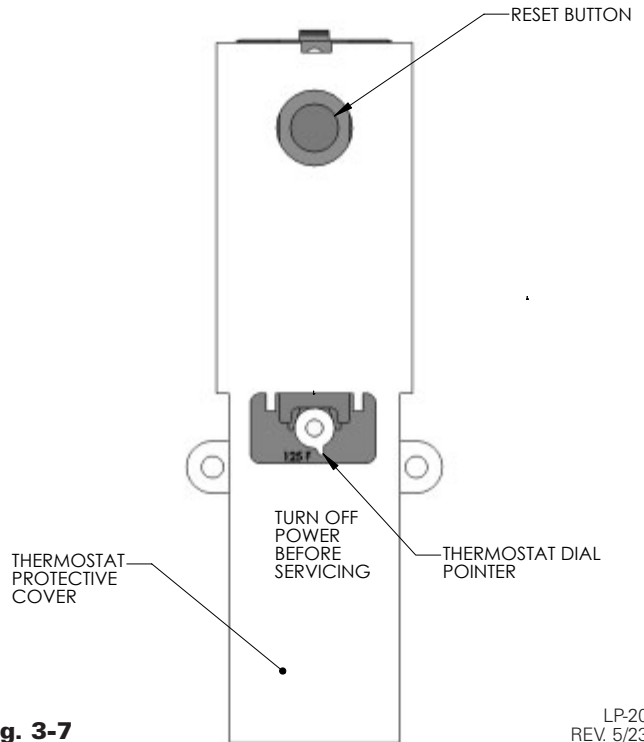

Fig. 3-7

LP-200-J
REV. 5/23/07

PART 3: SOLAR WATER HEATER INSTALLATION (CONT'D)

TOTAL COLLECTOR LOOP FLUID CAPACITY IN GALLONS*

- | | |
|-----------------------------|--------------------|
| 1. Collection System | 3.5 gallons |
| 2. Collection System | 4.5 gallons |

*Assumes a total 100' pipe run using 3/4" Type M hard copper tubing.
The SuperStor Solar heat exchanger has a 1.5 gallon fluid capacity

Open the upper fill valve (#18) and allow the pressure from the expansion tank to push the water in the glycol loop back to prime the pressure pump. When the hose in the bucket containing the glycol mixture stops bubbling, you may begin charging the collector loop with glycol. With both fill and drain valves open, run the low flow diaphragm pump until the glycol mixture begins flowing into the empty bucket. Quickly switch the hose from the empty/return bucket to the bucket containing the glycol mixture. Continue to circulate the fluid using the pressure pump until the bubbling has stopped and the air has been purged.

After charging the collector loop, shut the lower drain valve (#10) and let the pressure pump drive up the loop pressure to the appropriate level (generally in the range of 25 PSI). To more accurately calculate the proper pressure, measure the height of the solar collector above the SuperStor Solar Tank and divide this number by 2.31, then add 20 PSI to this number.

CAUTION

The pressure in the glycol loop should not exceed 45 PSI when the system is in operation on a sunny day. Contact your Solar Contrator if your collector loop exceeds this threshold.

After pressurizing the solar system, run the circulator and allow the air to purge out of the air vent. Once purged, monitor pressures and check for leaks before insulating pipes. Pressure should then be about 25 PSI.

Above ground piping must be insulated with a wall thickness of at least 3/4". A 1" thickness is required in areas prone to hard freeze conditions. Above ground insulation must be protected from Ultra violet degradation. All piping must be supported at a maximum interval of 10 feet and the piping supports must not crimp or compress the insulation.

COMMISSIONING THE SYSTEM

After the glycol loop has been charged and pressure is around 25 PSI (Check Gauge on Solar Heat Exchanger) set the solar control to the desired settings. Solar controls come with default settings that will work in most installations. If it is a cloudy day, you may have to activate the circulator pump. Once the pump is running and the system is fully purged, set the control to the desired settings. It is recommended that the storage tank high limit set point is not set any lower the 160° F. A lower set point could lower the performance of the solar water heater and could cause over heating of the collector system. You must install an anti-scald valve on the hot water outlet as temperature within the storage tank can cause injury – please see warning below on temperature outlet temperature restriction.

DANGER

DANGER

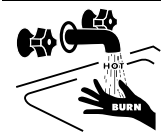

Water temperature over 125 degrees F. can cause severe burns instantly, or death from scalds. Children, disabled, and elderly are at highest risk of being scalded. See instruction manual before setting temperature at water heater. Feel water before bathing or showering! Temperature limiting valves are available.

DANGER



PART 4: MAINTENANCE

A properly maintained Solar Water Heating system can provide years of dependable trouble free service. It is suggested that routine preventive maintenance program be established and followed by the end user with his contractor. Listed below is the maintenance check list that outlines the primary components of the solar system that need to be inspected annually.

1. HTF Glycol - It is very important that the quality of the HTF Glycol is maintained to avoid damage to the collector loop and related components which come in contact with the fluid. See the Dow Frost Data Sheet located in the back of the manual for further details.
2. Water Quality can effect the operation of the solar heat exchanger over time. In very hard water areas, it is recommended you drain (#14) a few gallons from the water to keep the bottom of the water heater free of sediment.
3. Clean and inspect the solar collector (#1) Dirt or film may have settled on the surface and may effect the performance. Check Collector supplier for clean procedures.
4. Check Insulation for deterioration.
5. Check Solar Tank Sensors and the Boiler back up Aquastat Sensors (#15 & 23) to assure that they are secure and have not moved or loosen.
6. Inspect the T&P (#19) on the water heater. Lift the release handle lever and make discharge is directed to an open drain.
7. The area near the water heater must be kept free of flammable liquids such as gasoline, paint thinners, adhesive or other combustible materials.
8. The electric element may need cleaning – A hissing sound while operating will happen when the element starts to build up deposits that will require cleaning. This should be done only by a qualified individual or licensed plumber.

CAUTION

If the heating element needs replacement, it is VERY important to use the same voltage, wattage and construction. This element must be stainless steel and the hex plug be made of brass. This replacement part is available from the manufacturer and should not be purchased from outside sources.

SHUT DOWN PROCEDURES

The Solar System is designed to be easily isolated for emergency repairs or routine maintenance. To isolate the water heater, simply shut down the supply water shut off valve (Number #24) which isolates the water heater from the pressurized cold water supply.

The collector loop can be isolated from the solar storage tank by closing (#6 and #11). If the pressure in this loop drops or you find a glycol leak, close these valves, turn the circulating pump off by shutting down the power to the solar control and contact your installation contractor.

VACATION SHUT DOWN

Solar water heaters can build up very high temperatures when there is no daily draw on the system. The best way to dissipate heat in the system is set the control to run your circulator pump 24 hours a day to cool off the storage tank at night. The collector will radiate heat back to the atmosphere at night, preventing the system from stagnating at very high temperatures.

PART 4: MAINTENANCE (CONT'D)

ESTIMATED LIFE OF COMPONENTS

Proper care and Maintenance of your solar system will determine the life expectancy of the individual components of the system. Refer to the manufactures warranty of the individual components for warranty coverage. To obtain warranty service, call your local service or installing contractor.

WARNING

Following installation of the T & P Relief Valve, the valve lever MUST be operated AT LEAST ONCE A YEAR by the water heater owner to ensure that waterways are clear. Certain naturally occurring mineral deposits may adhere to the valve, blocking waterways, rendering it inoperative. When the lever is operated, hot water will discharge if the waterways are clear. PRECAUTIONS MUST BE TAKEN TO AVOID PERSONAL INJURY FROM CONTACT WITH HOT WATER AND TO AVOID PROPERTY DAMAGE. BEFORE operating lever, check to see that a discharge line is connected to the valve, directing the flow of hot water from the valve to a proper place of disposal. If no water flows when the lever is operated, replacement of the valve is required. **TURN THE WATER HEATER "OFF" AND CALL A PLUMBER IMMEDIATELY.**

This device is designed for emergency safety relief and shall not be used as an operating control. A relief valve functions, in an emergency, by discharging water. Therefore, it is essential that a discharge line be piped from the valve in order to carry the overflow to a safe place of disposal. The discharge line must be the same size as the valve outlet and must pitch downward from the valve and terminate at least 6" above a drain where any discharge will be clearly visible.

PART 4: MAINTENANCE (CONT'D)

SUPERSTOR SB SERIES SOLAR WATER HEATER (with BACK-UP HEAT EXCHANGER)

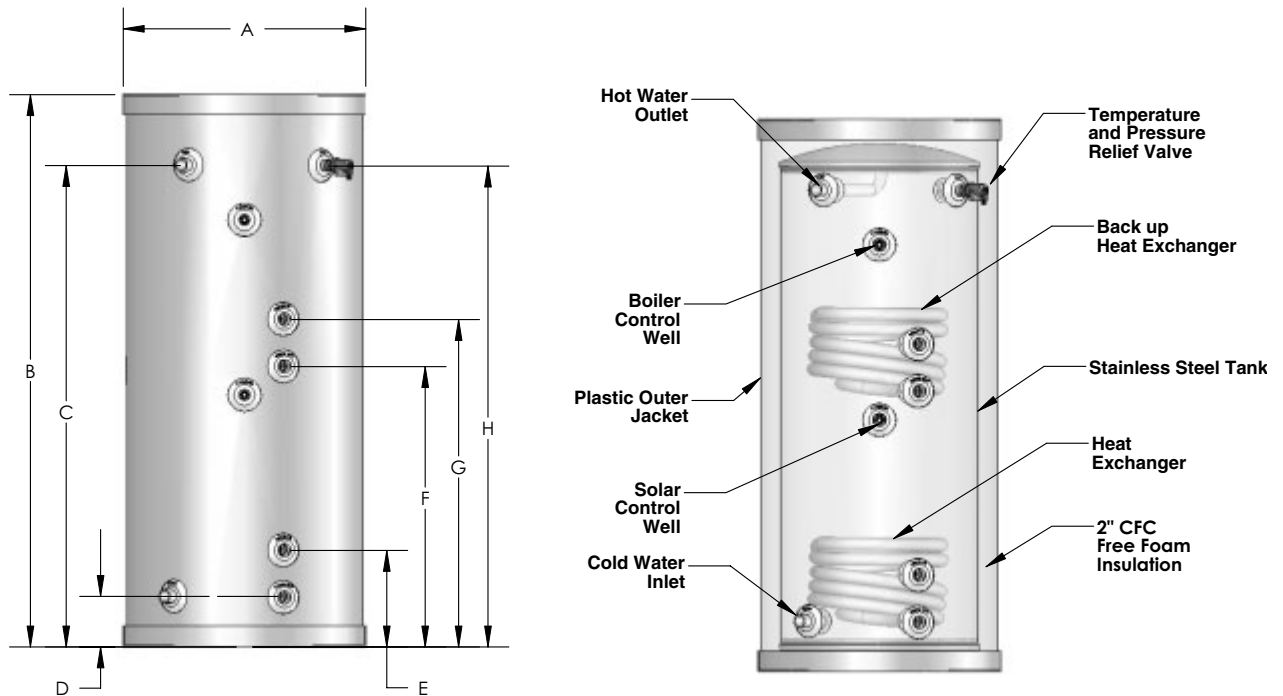

SUPERSTOR SOLAR WATER HEATER DIMENSIONS									
MODEL #	GAL.	DIMENSIONS							
		A	B	C	D	E	F	G	H
SSU-60SB	60	23"	52"	46"	5"	9-1/4"	26-1/2"	31"	46"
*SSU-80SB	80	23"	72"	64-1/2"	5"	9-1/4"	36-1/2"	41-1/2"	64-1/2"
*SSU-119SB	119	27"	74"	66-1/2"	7-1/2"	11-1/4"	38-1/2"	43-1/2"	66-1/2"

SUPERSTOR SOLAR WATER HEATER SPECS						
MODEL #	GAL.	HEAT EXCHANGER OUTLET SIZE	INLET/OUTLET SIZE	DRY WEIGHT	WET WEIGHT	SHIPPING WEIGHT (lbs)
SSU-60SB	60	1" NPT	1" NPT	100	492	120
*SSU-80SB	80	1" NPT	1" NPT	131	656	151
*SSU-119SB	119	1" NPT	1" NPT	210	1722	220

* DW SOLAR COIL MODELS SPECIAL ORDER, CONSULT FACTORY

SUPERSTOR SOLAR SB SERIES									
MODEL	HX VOLUME GALLONS		HEATED WATER VOLUME OF BACK UP	MAX. OPERATING PRESSURE OF COIL	RECOVERY OF BACK UP IN MINUTES		BOILER OUTPUT FOR TEST RECOVERIES	FIRST DRAW *	
	SOLAR	BOILER			65 ° RISE	90 ° RISE		65 ° RISE	90 ° RISE
SSU-60SB	1 GAL	1 GAL	35 GAL	150 PSI	11 MIN	16 MIN	104,000 BTU/HR	40 GAL	28 GAL
SSU-80SB	1 GAL	1 GAL	49 GAL	150 PSI	14 MIN	19 MIN	114,000 BTU/ HR	60 GAL	40 GAL
SSU-119SB	1 GAL	1 GAL	64 GAL	150 PSI	22 MIN	31 MIN	121,000 BTU/HR	90 GAL	60 GAL

* AMOUNT OF WATER DRAWN OUT OF STORAGE TANK WITHOUT ANY ENERGY INPUT

All tank dimensions are approximate. Heat Transfer reserves the right to make product changes or updates without notice. Heat Transfer will not be held liable for typographical errors in literature. For questions, please consult the factory.

Fig. 4-1

LP:196
REV. 3/27/08

PART 4: MAINTENANCE (CONT'D)

SUPERSTOR SE SERIES SOLAR WATER HEATER (with BACK-UP ELECTRIC ELEMENT)

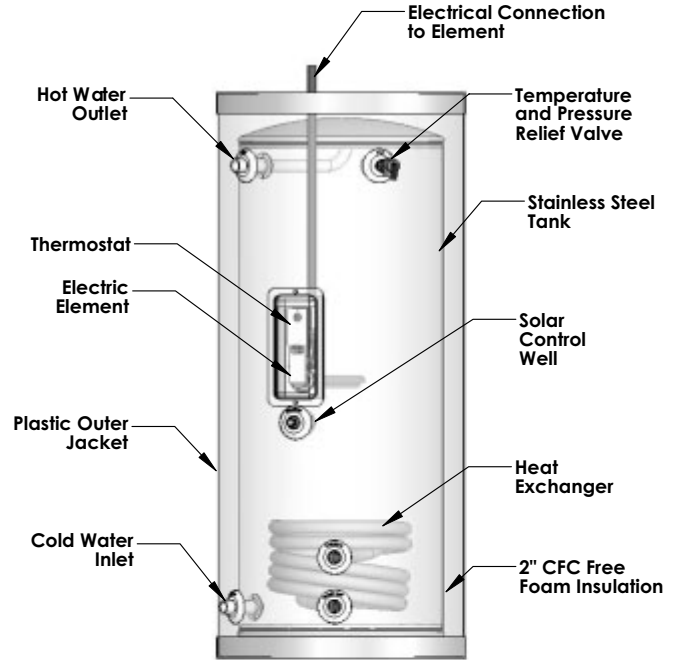
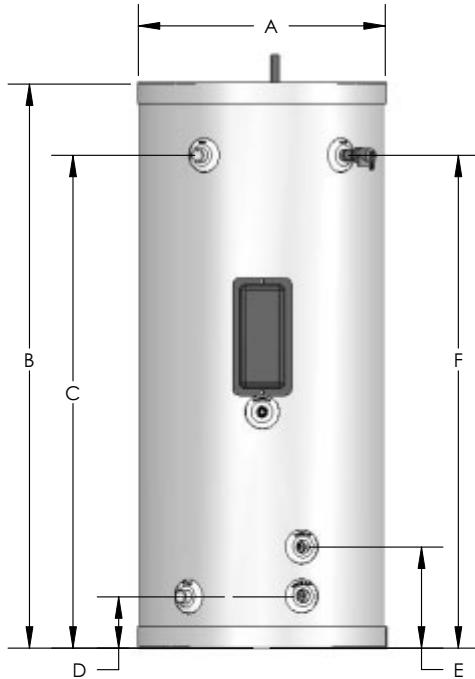

SUPERSTOR SOLAR WATER HEATER DIMENSIONS							
MODEL #	GAL.	DIMENSIONS					
		A	B	C	D	E	F
SSU-60SE	60	23"	52"	46"	5"	9-1/4"	46"
*SSU-80SE	80	23"	72"	64-1/2"	5"	9-1/4"	64-1/2"
*SSU-119SE	119	27"	74"	66-1/2"	7-1/2"	11-1/4"	66-1/2"

SUPERSTOR SOLAR WATER HEATER SPECS						
MODEL #	GAL.	HEAT EXCHANGER OUTLET SIZE	INLET/OUTLET SIZE	DRY WEIGHT	WET WEIGHT	SHIPPING WEIGHT (lbs)
SSU-60SE	60	1" NPT	1" NPT	90	492	115
*SSU-80SE	80	1" NPT	1" NPT	121	656	146
*SSU-119SE	119	1" NPT	1" NPT	200	1722	215

* DW SOLAR COIL MODELS SPECIAL ORDER, CONSULT FACTORY

SUPERSTOR SOLAR SE SERIES							
MODEL	SOLAR HX VOLUME GALLONS	WATER VOLUME OF BACK UP	MAX. OPERATING PRESSURE OF COIL	RECOVERY OF BACK UP IN MINUTES		FIRST DRAW*	
				65° RISE	90° RISE	65° RISE	90° RISE
SSU-60SE	1 GAL	35 GAL	150 PSI	74 MIN	102 MIN	40 GAL	28 GAL
SSU-80SE	1 GAL	49 GAL	150 PSI	104 MIN	143 MIN	60 GAL	40 GAL
SSU-119E	1 GAL	64 GAL	150 PSI	135 MIN	187 MIN	90 GAL	60 GAL

* AMOUNT OF WATER DRAWN OUT OF STORAGE TANK WITHOUT ANY ENERGY INPUT

All tank dimensions are approximate. Heat Transfer reserves the right to make product changes or updates without notice. Heat Transfer will not be held liable for typographical errors in literature. For questions, please consult the factory.

Fig. 4-2

LP-195
REV. 3/27/08

PART 4: MAINTENANCE (CONT'D)

**SUPERSTOR SOLAR SE MODELS
(w/Electric Back-up)**

PARTS BREAKDOWN

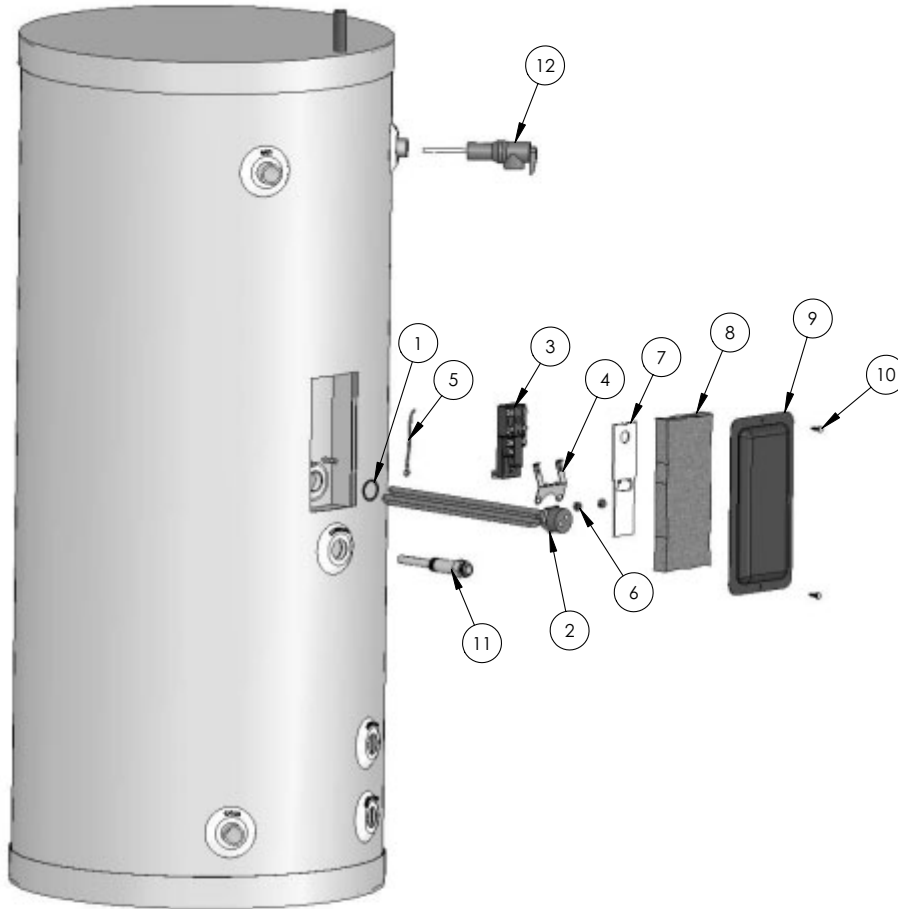

Item No	Replacement Part #	Description	QTY.
1	N/A	O-RING - ELECTRIC ELEMENT (#213 EDPM)	1
2*	E1001	ELECTRIC ELEMENT (W/O-RING)	1
3	TD1015	UPPER THERMOSTAT CONTROL	1
4	6060P-633	THERMODISC MOUNTING CLIP	1
5	6060P-630	GREEN GROUND WIRE W/RING	1
6	6060P-632	5/16-18 HEX NUT - THERMODISC MOUNTING CLIP	2
7	6060P-636	PLASTIC PROTECTIVE COVER	1
8	6060P-635	MINERAL WOOL INSULATION	1
9	6060P-187	ELECTRICAL ENCLOSURE COVER	1
10	6075P-006	#8 X 3/4" SELF TAPPING SCREW - ELECTRICAL ENCLOSURE COVER	2
11	PMW-3SENP-1	STAINLESS STEEL CONTROL WELL	1
12	TP1000	3/4" RELIEF VALVE	1

***CAUTION: If the heating element needs replacement, it is VERY important to use the same voltage , wattage and construction. This element must be stainless steel and the hex plug be made of brass. This replacement part is available from the manufacturer and should NOT be purchased from outside sources.**

Fig. 4-3

PART 4: MAINTENANCE (CONT'D)

**SUPERSTOR SOLAR SB MODELS
(w/Boiler Back-up)**

PARTS BREAKDOWN

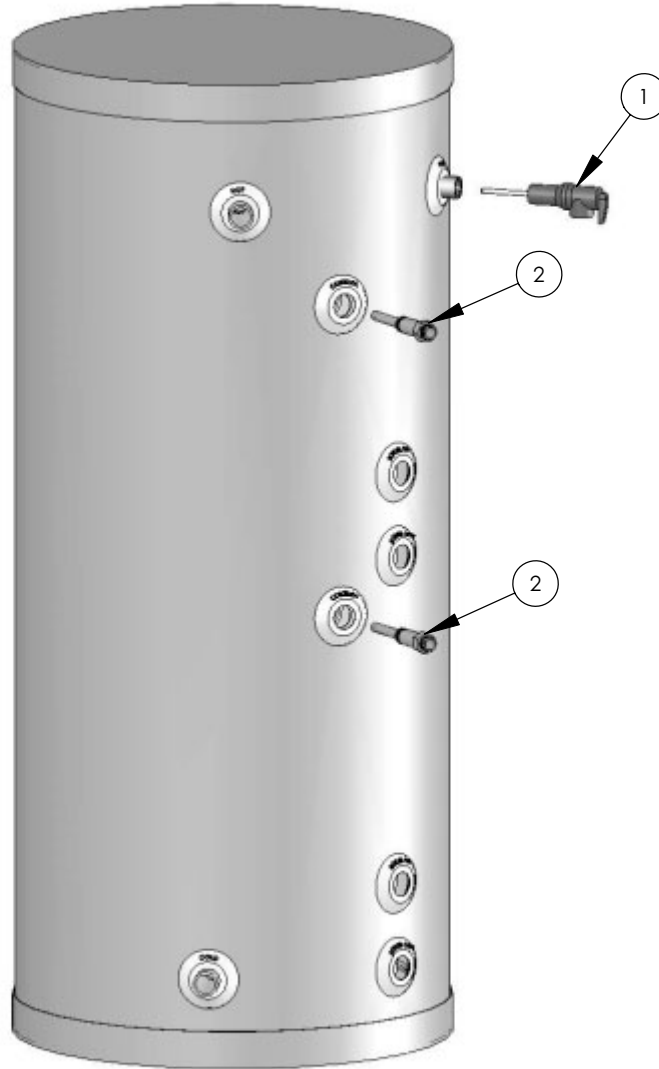

Item No	Replacement Part #	Description	QTY.
1	TP1000	3/4" RELIEF VALVE	1
2	PMW-3SENP-1	STAINLESS STEEL CONTROL WELL	1

Fig. 4-4

LP-199-E
REV. 3/19/08

PART 5: TROUBLESHOOTING

Nature of Trouble	Possible Cause	Service
No hot water	<ol style="list-style-type: none"> 1. Improper Wiring 2. No Power – blown fuse or circuit breaker tripped <ol style="list-style-type: none"> a. Shorted wiring b. Circuit overloaded c. Improper wiring d. Grounded element or thermostat 3. Manual Reset Limit (ECO) open <ol style="list-style-type: none"> a. Thermostat defective b. Thermostat out of calibration c. Heat build-up due to loose wires d. Defective Limit (ECO) 4. Solar System Incorrectly Installed 5. Defective Element 6. Leaking plumbing or open hot water faucet(s) 	<p>Rewire per Wiring Diagram</p> <p>** Replace or repair ** Provide adequate circuit or reduce load ** Rewire per diagram ** Replace</p> <p>Refer to “Operation” Section ** Replace ** Lower setting or replace ** Tighten wire connections</p> <p>** Replace ** Check Installation ** Replace Element Make sure all faucet(s) are closed and check water meter.</p>
Not enough hot water	<ol style="list-style-type: none"> 1. Heater undersized 2. Defective Element 3. Defective thermostat or wired incorrectly 4. Solar System Incorrectly Installed 5. See #6 above (in No Hot Water) 	<p>Reduce rate of hot water use</p> <p>** Check amperage, replace element ** Check wiring or replace ** Check Installation</p>
Water too hot or not hot enough	<ol style="list-style-type: none"> 1. Thermostat setting too high or low 2. Thermostat out of calibration 3. Solar System Incorrectly Installed 4. Grounded Element 	<p>Change setting as required</p> <p>** Replace ** Check Installation ** Replace</p>
Noisy heating element	<ol style="list-style-type: none"> 1. Scale build-up on element 	<p>** Remove and clean</p>

⚠ CAUTION

****For your safety, DO NOT attempt repair of Electrical Wiring, Thermostat, Heating Element or other Operating Controls. Refer repairs to qualified service personnel.**



DOWFROST HD

Inhibited Propylene Glycol-based Heat Transfer Fluid

DOWFROST* HD heat transfer fluid is a formulation of 94.0 percent propylene glycol and a specially designed package of industrial corrosion inhibitors. The fluid is dyed bright yellow to aid in leak detection. Solutions in water provide freeze protection to below -50°C (-60°F) and burst protection to below -73°C (-100°F).

Recommended use temperature range:
-45°C (-50°F) to 160°C (325°F)

Suitable applications: single fluid process heating and cooling, closed-loop, water-based HVAC applications where propylene glycol solutions are preferred or required.

For health and safety information for this product, contact your Dow sales representative or call the number for your area on the second page of this sheet for a Material Safety Data Sheet (MSDS).

Typical Concentrations of DOWFROST HD Fluid Required to Provide Freeze and Burst Protection at Various Temperatures

Temperature °C (°F)	Percent DOWFROST HD Fluid Concentration Required	
	For Freeze Protection Volume %	For Burst Protection Volume %
-7 (20)	18	12
-12 (10)	29	20
-18 (0)	36	24
-23 (-10)	42	28
-29 (-20)	46	30
-34 (-30)	50	33
-40 (-40)	54	35
-46 (-50)	57	35
-51 (-60)	60	35

NOTE: These figures are examples only and may not be appropriate to your situation. Generally, for an extended margin of protection, you should select a temperature in this table that is at least 3°C (5°F) lower than the expected lowest ambient temperature. Inhibitor levels should be adjusted for solutions of less than 20% glycol. Contact Dow for information on specific cases or further assistance.

ATTENTION: These are typical numbers only and are not to be regarded as specifications. As use conditions are not within its control, Dow does not guarantee results from use of the information or products herein; and gives no warranty, express or implied.

Typical Freezing and Boiling Points of DOWFROST HD Fluid†

Wt. % Propylene Glycol	Vol. % Propylene Glycol	Wt. % DOWFROST HD	Vol. % DOWFROST HD	Freezing Point °C (°F)	Boiling Point °C @ 101 kPa (°F @ 760 mmHg)	Degree Brix††	Refractive Index 22°C (72°F)
0.0	0.0	0.0	0.0	0 (32.0)	100.0 (212)	0.0	1.3328
5.0	4.8	5.3	5.1	-1.6 (29.1)	100.0 (212)	4.8	1.3383
10.0	9.6	10.7	10.2	-3.3 (26.1)	100.0 (212)	8.4	1.3438
15.0	14.5	16.0	15.4	-5.1 (22.9)	100.0 (212)	12.9	1.3495
20.0	19.4	21.3	20.6	-7.1 (19.2)	100.6 (213)	15.4	1.3555
25.0	24.4	26.6	26.0	-9.6 (14.7)	101.1 (214)	19.0	1.3615
30.0	29.4	31.9	31.3	-12.7 (9.2)	102.2 (216)	22.0	1.3675
35.0	34.4	37.2	36.6	-16.4 (2.4)	102.8 (217)	26.1	1.3733
40.0	39.6	42.6	42.1	-21.1 (-6.0)	103.9 (219)	29.1	1.3790
45.0	44.7	47.9	47.6	-26.7 (-16.1)	104.4 (220)	31.8	1.3847
50.0	49.9	53.2	53.1	-33.5 (-28.3)	105.6 (222)	34.7	1.3903
55.0	55.0	58.5	58.5	-41.6 (-42.8)	106.1 (223)	38.0	1.3956
60.0	60.0	63.8	63.8	-51.1 (-59.9)	107.2 (225)	40.6	1.4008
65.0	65.0	69.1	69.1	b	108.3 (227)	42.1	1.4058
70.0	70.0	74.5	74.5	b	110.0 (230)	44.1	1.4104
75.0	75.0	79.8	79.8	b	113.9 (237)	46.1	1.4150
80.0	80.0	85.1	85.1	b	118.3 (245)	48.0	1.4193
85.0	85.0	90.4	90.4	b	125.0 (257)	50.0	1.4235
90.0	90.0	95.7	95.7	b	132.2 (270)	51.4	1.4275
95.0	95.0	a	a	b	154.4 (310)	52.8	1.4315

† Typical properties, not to be construed as specifications.

†† Degree Brix is a measure of the sugar concentration in a fluid and is important in fermentation and syrups applications. Although there is no sugar present in DOWFROST heat transfer fluids, the glycol affects the refractive index of the fluid in a similar fashion.

^a Propylene glycol concentrations greater than 94% are not attainable with DOWFROST HD fluid.

^b Freezing points are below -50°C (-60°F).

NOTE: Generally, for an extended margin of protection, you should select a temperature in this table that is at least 3°C (5°F) lower than the expected lowest ambient temperature. Inhibitor levels should be adjusted for solutions of less than 20% glycol. Contact Dow for information on specific cases or further assistance.

DOWFROST HD

Inhibited Propylene Glycol-based Heat Transfer Fluid

Typical Properties of DOWFROST HD Fluid[†]

DOWFROST HD Heat Transfer Fluid	
Composition (% by weight)	
Propylene Glycol	94
Performance Additives	6
Color	Fluorescent Yellow
Specific Gravity	
15/15°C (60/60°F)	1.053–1.063
pH of Solution	
(50% glycol)	9.5–10.5
Reserve Alkalinity (min.)	15.0 ml

[†]Typical properties, not to be construed as specifications. Complete sales specifications are available on request.

Saturation Properties of DOWFROST HD Fluid at 30% Propylene Glycol Concentration by Volume

Temp. °C (°F)	Specific Heat kJ/(kg)(K) (Btu/lb°F)	Density kg/m ³ (lb/ft ³)	Therm. Cond. W/mK [Btu/hr ft ² (°F/ft)]	Viscosity mPa·s (cps)
10 (50)	3.756 (0.898)	1043.85 (65.17)	0.4344 (0.2510)	4.5068 (4.51)
40 (104)	3.841 (0.918)	1029.85 (64.29)	0.4622 (0.2670)	1.6295 (1.63)
65 (149)	3.913 (0.935)	1014.87 (63.36)	0.4771 (0.2757)	0.9144 (0.91)
90 (194)	3.984 (0.952)	996.86 (62.23)	0.4846 (0.2800)	0.6040 (0.60)
120 (248)	4.070 (0.973)	971.26 (60.63)	0.4838 (0.2795)	0.4246 (0.42)

Saturation Properties of DOWFROST HD Fluid at 40% Propylene Glycol Concentration by Volume

Temp. °C (°F)	Specific Heat kJ/(kg)(K) (Btu/lb°F)	Density kg/m ³ (lb/ft ³)	Therm. Cond. W/mK [Btu/hr ft ² (°F/ft)]	Viscosity mPa·s (cps)
-20 (-4)	3.453 (0.825)	1066.76 (66.60)	0.3635 (0.2100)	48.9043 (48.90)
10 (50)	3.564 (0.852)	1055.38 (65.89)	0.3936 (0.2274)	7.2173 (7.22)
40 (104)	3.675 (0.878)	1039.77 (64.91)	0.4150 (0.2398)	2.2389 (2.24)
65 (149)	3.767 (0.900)	1023.55 (63.90)	0.4262 (0.2463)	1.1762 (1.18)
90 (194)	3.859 (0.922)	1004.39 (62.70)	0.4313 (0.2492)	0.7462 (0.75)
120 (248)	3.970 (0.949)	977.53 (61.03)	0.4294 (0.2481)	0.5084 (0.51)

Saturation Properties of DOWFROST HD Fluid at 50% Propylene Glycol Concentration by Volume

Temp. °C (°F)	Specific Heat kJ/(kg)(K) (Btu/lb°F)	Density kg/m ³ (lb/ft ³)	Therm. Cond. W/mK [Btu/hr ft ² (°F/ft)]	Viscosity mPa·s (cps)
-30 (-22)	3.165 (0.756)	1081.98 (67.55)	0.3246 (0.1875)	172.8273 (172.83)
-20 (-4)	3.210 (0.767)	1078.51 (67.33)	0.3336 (0.1927)	73.0193 (73.02)
10 (50)	3.346 (0.800)	1065.40 (66.51)	0.3560 (0.2057)	10.6481 (10.65)
40 (104)	3.481 (0.832)	1048.23 (65.44)	0.3716 (0.2147)	3.1103 (3.11)
65 (149)	3.594 (0.859)	1030.83 (64.35)	0.3792 (0.2191)	1.5483 (1.55)
90 (194)	3.707 (0.886)	1010.61 (63.09)	0.3821 (0.2208)	0.9339 (0.93)
120 (248)	3.843 (0.919)	982.63 (61.34)	0.3792 (0.2191)	0.6029 (0.60)

For further information, call...

In the United States and Canada: 1-800-447-4369 • FAX: 1-989-832-1465

In Europe: +32 3 450 2240 • FAX: +32 3 450 2815

In the Pacific: +886 22 547 8731 • FAX: +886 22 713 0092

In other Global Areas: 1-989-832-1560 • FAX: 1-989-832-1465

www.dowfrost.com

NOTICE: No freedom from any patent owned by Seller or others is to be inferred. Because use conditions and applicable laws may differ from one location to another and may change with time, Customer is responsible for determining whether products and the information in this document are appropriate for Customer's use and for ensuring that Customer's workplace and disposal practices are in compliance with applicable laws and other governmental enactments. Seller assumes no obligation or liability for the information in this document. NO WARRANTIES ARE GIVEN; ALL IMPLIED WARRANTIES OF MERCHANTABILITY OR FITNESS FOR A PARTICULAR PURPOSE ARE EXPRESSLY EXCLUDED.

Published November 2001



PART 5: TROUBLESHOOTING (CONT'D)

VISCOSITY: The HTF Viscosity over the service temperature range is based on a specific gravity 15/15°C (60/60°F) 1.053-1.063. DOWFROST inhibited glycol-based fluid has an effective operating temperature range of -50°F to 250°F, while DOWFROST HD inhibited glycol-based fluid is effective from -50°F to 325°F. At temperatures below -50°F, increased viscosity (>1,000 centipoise) can make use of these fluids impractical unless larger pumps are installed. At the upper end of the operating range for DOWFROST fluid, a maximum bulk temperature of 250°F is recommended. Film temperatures should not exceed 300°F. In the case of DOWFROST HD fluid, a maximum bulk temperature of 325°F is recommended, with film temperatures not to exceed 375°F. DOWFROST and DOWFROST HD fluids can tolerate brief temperature excursions up to 100°F above the maximum recommended temperatures. However, extended exposure of the fluids to temperatures in excess of 50°F above the maximum recommended temperatures will result in accelerated degradation of the glycol and inhibitor systems. In addition, the film temperature should remain within 50°F of the bulk fluid temperature and the pressure at all points in the system should be at least 5 psi greater than the vapor pressure exerted by the fluid to avoid localized boiling and resulting precipitation. At temperatures above 150°F, the system must be closed to avoid rapid oxidation of the propylene glycol, inhibitor depletion, and subsequent increased corrosion. Automatic make-up water systems should be avoided in order to prevent undetected dilution or loss of glycol and consequent loss of freeze and corrosion protection.

FLAMMABILITY: When mixed with water, neither DOWFROST nor DOWFROST HD fluids are flammable because they have no measurable flash point (Pensky-Martens Closed Cup) in concentrations up to 80% glycol. Undiluted DOWFROST and DOWFROST HD have a flash point of 214°F (Pensky-Martens Closed Cup). It is possible to ignite solutions of propylene if enough water has been vaporized and the concentration of propylene glycol increases to greater than 80 percent.

INSPECTION AND TREATMENT OF HEAT TRANSFER FLUID: You can quickly determine the condition of your fluid by examining its appearance and odor. Any drastic variation from the initial fluid specifications, such as a black or dark-grey color, presence of an oily layer, burnt odor, or any heavy sludge in the fluid may indicate the need for fluid replacement.

TESTING YOUR FLUID'S pH LEVEL: Control of pH between 8 and 10 is important to minimize corrosion and glycol degradation. Using narrow range pH paper such as pHydration Control paper with a 7.2 to 8.8 pH range is an easy and reliable way to read your pH level. A pH tester can also measure alkalinity or acidity and give you an indication of the reserve alkalinity or inhibitor level of the fluid. The desirable pH range should fall between 8.0 and 10.0. Adjustments can be made using a 50% solution of sodium hydroxide or potassium hydroxide if the pH is approaching the acidic range (below 8.0). An inexpensive pH tester is available from Misco Products. The accuracy of this product is +/- 0.5 pH. Contact Misco Products at 1-800-358-1100 and ask for the Dow discount.

SPILL, LEAK AND DISPOSAL PROCEDURES FOR DOWFROST: Using appropriate safety equipment, small spills may be soaked up with common absorbent material. For large spills, the fluid should be pumped into suitable containers located in diked areas. Residual material should be cleaned up with water. Concentrate can be handled according to local, state, and federal regulations.

PART 5: TROUBLESHOOTING (CONT'D)**EMERGENCY OVERVIEW****POTENTIAL HEALTH EFFECTS**

EYE: May cause slight transient (temporary) eye irritation.
Corneal injury is unlikely. Mists may cause eye irritation.

FIRST AID: FLUSH EYES WITH PLENTY OF WATER

SKIN CONTACT: Prolonged contact is essentially non-irritating to skin. A single prolonged exposure is not likely to result in the material being absorbed through the skin in harmful amounts. Repeated exposure may cause flaking and softening of skin.

FIRST AID: WASH OFF IN FLOWING WATER OR SHOWER

INGESTION: Single dose oral toxicity is considered to be extremely low. No hazards anticipated from swallowing small amounts incidental to normal handling operations.

FIRST AID: NONE REQUIRED

INHALATION: At room temperature, vapors are minimal due to physical properties. Mists may cause irritation of upper respiratory tract (nose and throat)

**FIRST AID: REMOVE TO FRESH AIR IF EFFECTS OCCUR,
CONSULT A PHYSICIAN**

**NOTE TO PHYSICIAN: NO SPECIFIC ANTIDOTE.
SUPPORTIVE CARE. TREATMENT BASED ON
JUDGEMENT OF THE PHYSICIAN IN RESPONSE TO THE
REACTION OF THE PATIENT. CONSULT DOW CHEMICAL
24 HOUR EMERGENCY 989-636-4400**

LIST OF SOLAR COLLECTORS WITH MATCHING SOLAR TANK MODELS			
SYSTEM MODELS	SOLAR COLLECTOR COMPANY	COLLECTOR MODEL	# OF COLLECTORS NEEDED
SSU-60SE/SB	SUN EARTH INC.	EP-32	1
	AET	AE32E	1
	HEAT TRANSFER	HP-30SC	1
	APRICUS	AP-30	1
SSU-80SE/SB	SUN EARTH INC.	EP-40	1
	AET	AE40E	1
	HEAT TRANSFER	HP-30SC	1
	APRICUS	AP-30	1
SSU-80SE/SB-DW	SUN EARTH INC.	EP-40	1
	AET	AE40E	1
	HEAT TRANSFER	HP-30SC	1
	APRICUS	AP-30	1
SSU-119SE/SB	SUN EARTH INC.	EP-32	2
	AET	AE32E	2
	HEAT TRANSFER	HP-30SC	2
	APRICUS	AP-30	2
SSU-119SE/SB-DW	SUN EARTH INC.	EP-32	2
	AET	AE32E	2
	HEAT TRANSFER	HP-30SC	2
	APRICUS	AP-30	2

LP-199-M
REV. 2/26/08

SOLAR SYSTEM REPLACEMENT PARTS		
CONTROLLER	STECA	TRO301
	GOLDLINE	GL-30
	HELIOTROPE	Thermal Delta T
PUMP	TACO	007
	GRUNDFOS	15-58F
EXPANSION TANK	AMTROL	Extrol #30
CHECK VALVE	WATTS	SERIES 600*
		*(ALTERNATE APPROVED EQUIVALENT)
PRESSURE RELIEF VALVE	WATTS	3L (75 psig)
AIR VENT	TACO	417*
		*(ALTERNATE APPROVED EQUIVALENT)
MIXING VALVE	TACO	500 SERIES
	WATTS	1170 SERIES
	HONEYWELL	AM101 SERIES
	CACHE ACAC	HEATGUARD 110 SERIES
PIPING		ALL COPPER
HEAT TRANSFER FLUID	DOW CHEMICAL	DOWFROST HD

LP-199-M-1
REV. 11/1/07

SUPERSTOR SOLAR SRCC OG-300 LABEL SET

The following labels must be attached to the relevant valves in the system in order for it to be considered OG-300 compliant. This page should be laminated, each label cut from it, punched in the margin at the left hand side and affixed to the appropriate valve with a wire tie, plastic ties are inappropriate due to high operating temperatures. Failure to affix these labels will void the SRCC OG-300 system certification.

VALVE 6 COLLECTOR ARRAY ISOLATION VALVE

VALVE 6 IS NORMALLY OPEN DURING OPERATION . IT IS CLOSED TO ISOLATE THE STORAGE TANK FROM THE COLLECTOR ARRAY SHOULD THE STORAGE TANK NEED SERVICING OR REPLACING

VALVE 11 COLLECTOR ARRAY ISOLATION VALVE

VALVE 11 IS NORMALLY OPEN DURING OPERATION . IT IS CLOSED TO ISOLATE THE STORAGE TANK FROM THE COLLECTOR ARRAY SHOULD THE STORAGE TANK NEED SERVICING OR REPLACING

VALVE 8 COLLECTOR ARRAY FILL/DRAIN VALVE

PLEASE CONSULT YOUR INSTALLATION MANUAL FOR SPECIFIC FREEZE TOLERANCE INFORMATION.

A 60% CONCENTRATION OF DOWFROST HD PROPYLENE GLYCOL AND DISTILLED WATER CAN PROTECT YOUR SUPERSTOR SOLAR SYSTEM TO TEMPERATURES AS LOW AS -65° F. LOWER CONCENTRATIONS OF DOWFROST HD AND DISTILLED WATER WILL PROVIDE A LOWER LEVEL OF FREEZE PROTECTION.

VALVE 24 COLD WATER SUPPLY BALL VALVE

THIS VALVE IS NORMALLY OPEN AND ALLOWS POTABLE WATER TO FILL THE SOLAR STORAGE TANK. WHEN CLOSED, THE SOLAR STORAGE TANK IS ISOLATED FROM THE PRESSURIZED CITY COLD WATER SUPPLY LINE PIPING.

VALVE 8 COLLECTOR ARRAY FILL/DRAIN VALVE (WARNING HOT)

VALVE 8 IS NORMALLY CLOSED. WHEN OPEN, IT IS USED TO CHARGE AND DRAIN THE SOLAR COLLECTOR LOOP PIPING.

THE HEAT TRANSFER FLUID USED IN THIS SYSTEM IS DOWFROST HD PROPYLENE GLYCOL. IT MUST BE HANDLED AND DISPOSED OF IN ACCORDANCE WITH THE DOW CHEMICAL COMPANY MATERIAL SAFETY DATA SHEET. A COPY OF THE MSDS HAS BEEN PROVIDED WITH YOUR INSTALLATION MANUAL. NO OTHER FLUID SHALL BE USED THAT WOULD CHANGE THE ORIGINAL CLASSIFICATION OF THIS SYSTEM. UNAUTHORIZED ALTERATIONS TO THIS SYSTEM COULD RESULT IN A HAZARDOUS HEALTH CONDITION.

BE EXTREMELY CAREFUL WHEN DRAINING THIS FLUID. IT MAY BE DISCHARGED AT A VERY HIGH TEMPERATURE AND/OR PRESSURE.

VALVE 10 COLLECTOR ARRAY FILL/DRAIN VALVE (WARNING HOT)

VALVE 10 IS NORMALLY CLOSED. WHEN OPEN, IT IS USED TO CHARGE AND DRAIN THE SOLAR COLLECTOR LOOP PIPING.

THE HEAT TRANSFER FLUID USED IN THIS SYSTEM IS DOWFROST HD PROPYLENE GLYCOL. IT MUST BE HANDLED AND DISPOSED OF IN ACCORDANCE WITH THE DOW CHEMICAL COMPANY MATERIAL SAFETY DATA SHEET. A COPY OF THE MSDS HAS BEEN PROVIDED WITH YOUR INSTALLATION MANUAL. NO OTHER FLUID SHALL BE USED THAT WOULD CHANGE THE ORIGINAL CLASSIFICATION OF THIS SYSTEM. UNAUTHORIZED ALTERATIONS TO THIS SYSTEM COULD RESULT IN A HAZARDOUS HEALTH CONDITION.

BE EXTREMELY CAREFUL WHEN DRAINING THIS FLUID. IT MAY BE DISCHARGED AT A VERY HIGH TEMPERATURE AND/OR PRESSURE.

The solar system installer is to check the box beside the system that was actually installed.

	<p>This product certified by: Solar Rating and Certification Corporation 1679 Clearlake Road Cocoa, FL 32922 (321)638-1537</p> <p>www.solar-rating.org</p>	<p>Heat Transfer Products 120 Braley Road East Freetown, MA 02717</p> <p>SRCC Document OG-300</p>
<p>System Model:</p> <ul style="list-style-type: none"> <input type="checkbox"/> SSC-50SE <input type="checkbox"/> SSC-80SE <input type="checkbox"/> SSC-119SE <input type="checkbox"/> SSC-50SB <input type="checkbox"/> SSC-80SB <input type="checkbox"/> SSC-119SB <input type="checkbox"/> SSU-60SE <input type="checkbox"/> SSU-80SE <input type="checkbox"/> SSU-119SE <input type="checkbox"/> SSU-80SE-DW <input type="checkbox"/> SSU-119SE-DW <input type="checkbox"/> SSU-60SB <input type="checkbox"/> SSU-80SB <input type="checkbox"/> SSU-119-SB <input type="checkbox"/> SSU-80SB-DW <input type="checkbox"/> SSU-119SB-DW <input type="checkbox"/> PH-80S <input type="checkbox"/> PH-119S 	<p>SRCC Certification Number:</p> <ul style="list-style-type: none"> 300-2007-011A 300-2007-011B 300-2007-011C 300-2007-012A 300-2007-012B 300-2007-012C 300-2007-019A 300-2007-019B 300-2007-019C 300-2007-020A 300-2007-020B 300-2007-021A 300-2007-021B 300-2007-021C 300-2007-022A 300-2007-022B 300-2007-023A 300-2007-023B 	<p>Solar Energy Factor:</p> <ul style="list-style-type: none"> 1.7 1.8 2.4 1.7 1.9 2.4 1.6 1.8 2.3 1.8 2.3 1.6 1.9 2.3 1.8 2.4 1.5 2.3

Service Information

Contractor Name _____

Address _____

Phone Number _____

Emergency Number _____

Contractor Name _____

Address _____

Phone Number _____

Emergency Number _____

Contractor Name _____

Address _____

Phone Number _____

Emergency Number _____

Contractor Name _____

Address _____

Phone Number _____

Emergency Number _____

The SuperStor Solar Water Heater
is manufactured by

Heat Transfer Products, Inc.
120 Braley Rd.
P.O. Box 429
East Freetown, MA 02717-0429
www.htproducts.com

