

DiaNorm Towel Warmers – Innovation by Design –

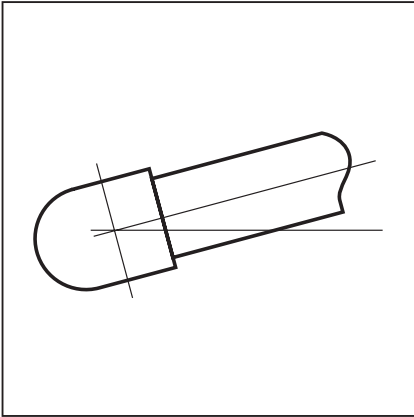

*DiaNorm "Noblesse NB" Towel Warmers
Affordable Comfort and Elegance
Plus Individual Room Temperature Control*

DiaNorm "Noblesse NB" Towel Warmers



"Noblesse NB" Towel Warmers are made of precision round 1" x 1 mm steel tubes. The horizontal bars are slightly bent forward, the vertical tubes are "D"- shaped and straight (1 1 / 2" x 1.5 mm).

Built to the highest design and quality standards by DiaNorm of Germany.

DiaNorm is a fully owned subsidiary of Rettig Heating Group, the world's largest manufacturer of steel panel radiators.

"Noblesse NB" has been designed for hot water (no steam) with operating pressures of up to 120 psi and temperatures of up to 220° F. Supply and return water tapings (1/2" fem.) are located at the bottom of the vertical tubes and reversible.

A standard 1/8" air bleeder is installed at the top of the right hand vertical tube.

Mounting brackets are included. Matching thermostatic valves (with or without built-in flow setter) and non-elec-

tric thermostatic actuators are optional.

DiaNorm Towel Warmers come with a 5 year Limited Warranty.

Standard finish is white epoxy powder coating to RAL 9016 that can easily be painted over with any other color. However, many additional colors are available from the factory with a lead time of 6-8 weeks.

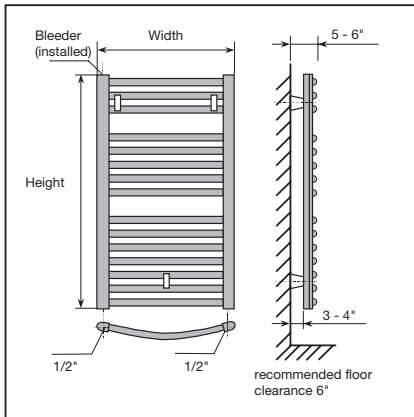

Dimensions and outputs of models kept in US inventory:

Width in.	Height in.	Output* BTU/H	Water Capacity	Weight net
23 5/8"	31 1/2"	2,000	1.2 Gal	16.5 lbs
23 5/8"	47 1/4"	3,000	1.8 Gal	25.0 lbs
23 5/8"	70 7/8"	4,500	2.7 Gal	35.0 lbs

*Outputs at 190/170° F supply/return and 68° F room temperature.
Additional models and colors are available with 6-8 weeks lead time.

Your distributor:



Purmo DiaNorm Wärme AG
D-38688 Vienenburg
Germany
Internet www.dianorm.de
A Company of RETTIG HEATING GROUP